

Creative Commons 4.0 NC SA BY FREE DISTRIBUTION ONLY - NOT FOR SALE

Grandmother Clark's Patchwork Quilt Designs

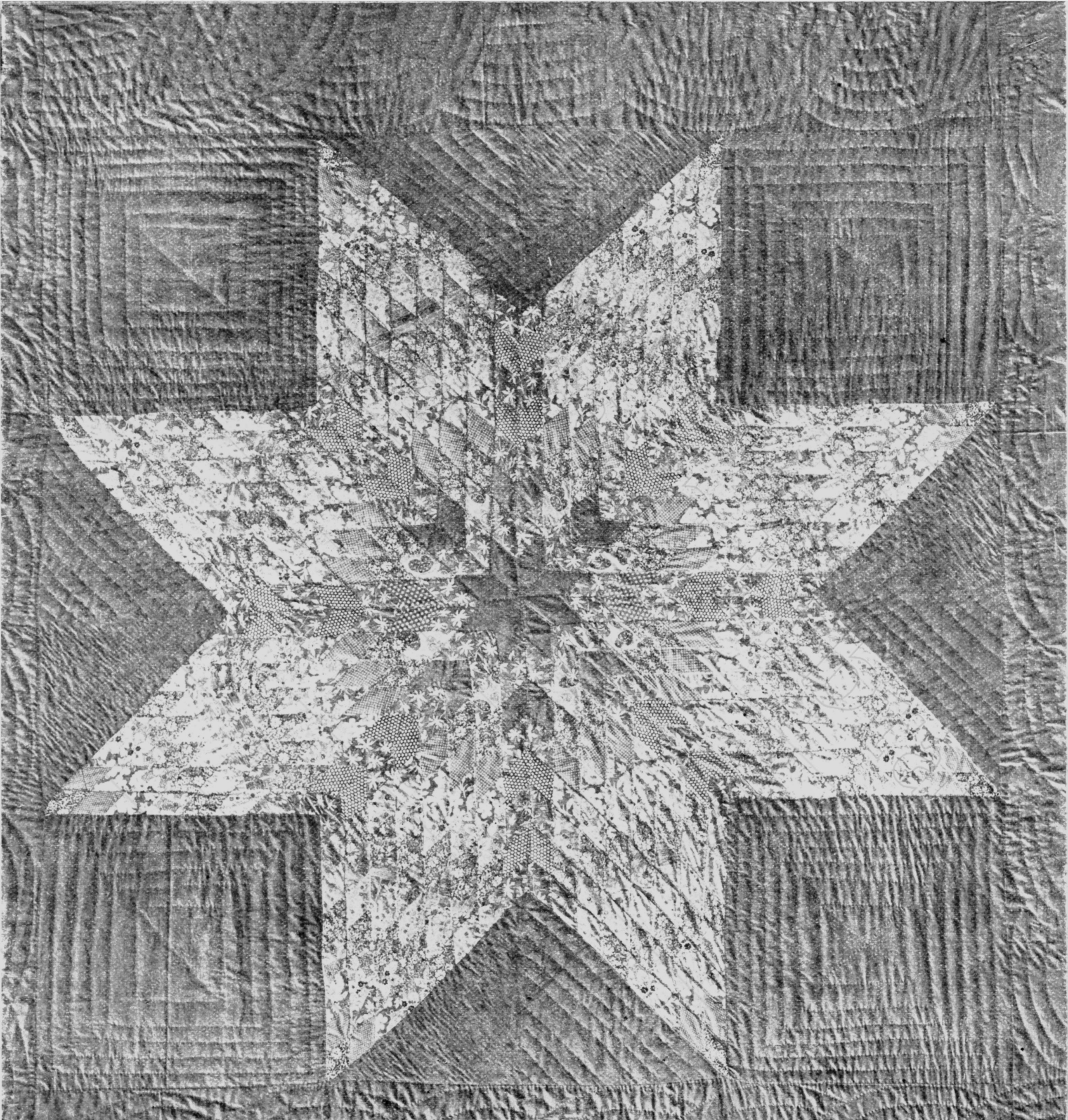

LARGE ILLUSTRATIONS www.antiquepatternslibrary.org 2024. **BOOK № 20.**

Grandmother Clark's Patchwork Quilt Designs

In the pioneer days of our grandmothers, every home, even to the little log cabin, had its share of patchwork quilts. There was a fascination in working out various designs from scraps left from dresses and other garments. There was calm and contentment in sewing the tiny pieces together till they gradually took on the semblance of flowers, stars, rings, or other fanciful figures.

Now, women are again learning the charm of quilting and finding some of the keen pleasure that our grandmothers knew in this old and useful art.

This book contains some of the most popular patchwork quilt designs which may be set together piece by piece to form a design or block, or they may be applied on squares of any desired color of cloth.

All cutting patterns shown in this book are finished size, so it will be necessary to allow for seams to secure the desired result.

To make cutting pattern trace on thin paper and paste on cardboard and cut out, or pattern can be traced on cardboard direct with carbon paper.

When cutting the patches be sure to allow $\frac{1}{4}$ inch for all seams. After patches are cut out, the edges are turned over the cardboard and pressed. For stems and connecting lines cut material on the bias. To applique these patterns trace a pattern on the material to be used for the background and applique patches on outline. Nine attractive ways of setting blocks together are shown on Page 15.

A SET OF EIGHT CUT-OUT FIBRE DIAGRAMS WITH $\frac{1}{4}$ inch allowed for seams, will be sent on receipt of 15c. This set contains the cut-outs for the following Quilts:

"Double Wedding Ring"	"Flower Garden"	"Basket"	"Dresden Plate"
"Eight-Pointed Star"	"Texas Star"	"Log Cabin"	"Yo-Yo or Bed of Roses"

Clark's Series of Art Needlework Books

These books are the most reliable instruction books on Art Needlework. Beautiful illustrations. Simple working instructions.

- | | |
|--|--|
| No. 1. Crochet and tatting edges, insertions, etc. | No. 11. New ways to knit. |
| No. 2. Crocheted yokes and boudoir caps. | No. 12. Crochet toys. |
| No. 3. Crochet yokes, etc., in filet, etc. | No. 13. (Spanish) Para labores de crochet. |
| No. 4. Crochet center pieces, doilies, etc. | No. 14. New crochet collars, etc. |
| No. 5. Crochet for children's garments. | No. 15. Transfer designs for applique and embroidery. |
| No. 6. Tatting and crochet. | No. 16. Transfer designs for initials and monograms. |
| No. 7. New knitted sweaters. | No. 17. Transfer designs for embroidery on handkerchiefs, towels, etc. |
| No. 8. How to make rag rugs by hand. | No. 18. Transfer designs for cross-stitch embroidery. |
| No. 9. Crochet edges, insertions and medallions. | No. 19. Transfer handkerchief embroidery designs. |
| No. 10. Knitted and crocheted sport garments. | No. 20. Patchwork quilt designs. |
| | No. 21. Old-fashioned quilt designs. |
| | No. 22. Quilting designs. |

Copyright, 1931
W. L. M. CLARK, INC.
St. Louis, Mo.

No. 1—Small Double Wedding Ring. Complete ring on 18-inch block. Use 5 pieces diagram "E" for one-fourth of each circle. Use diagram "F" (in solid colors) for black and white squares on diagram. Diagram "C" shows proper size for white melon-shape spaces.

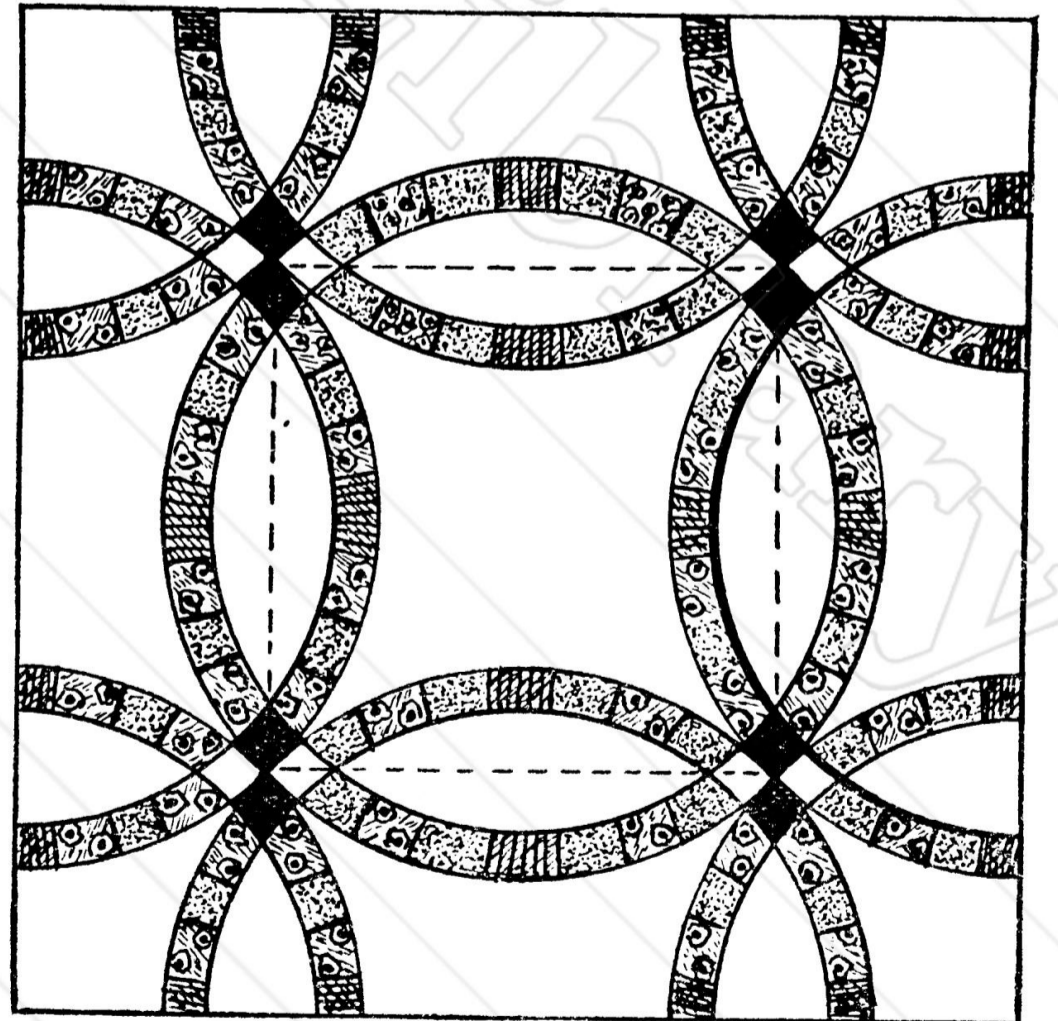
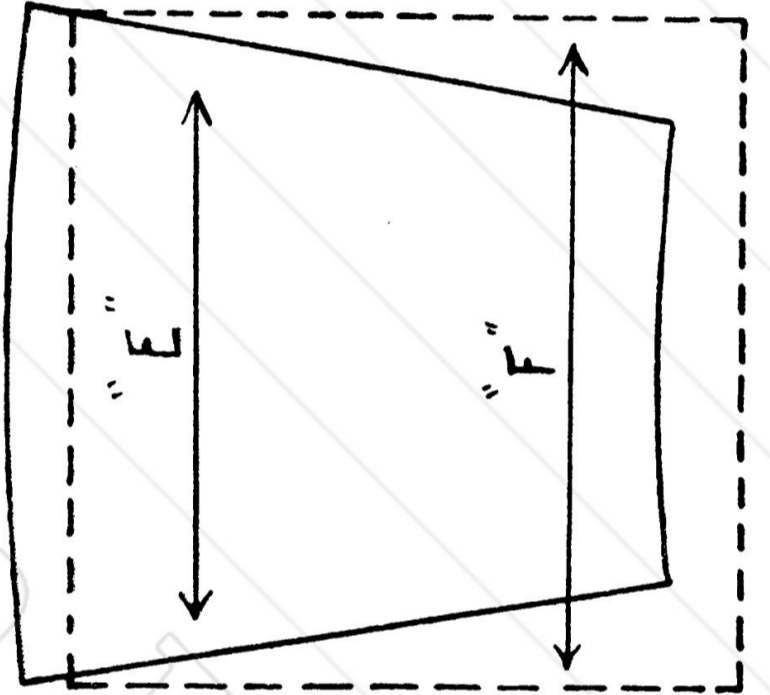
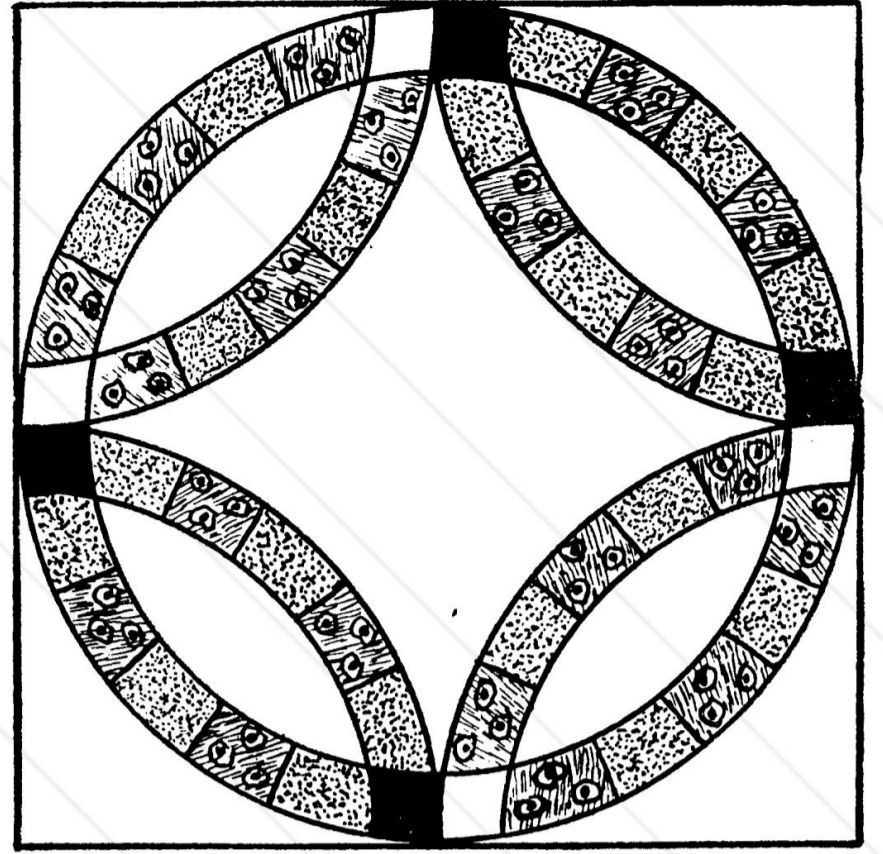
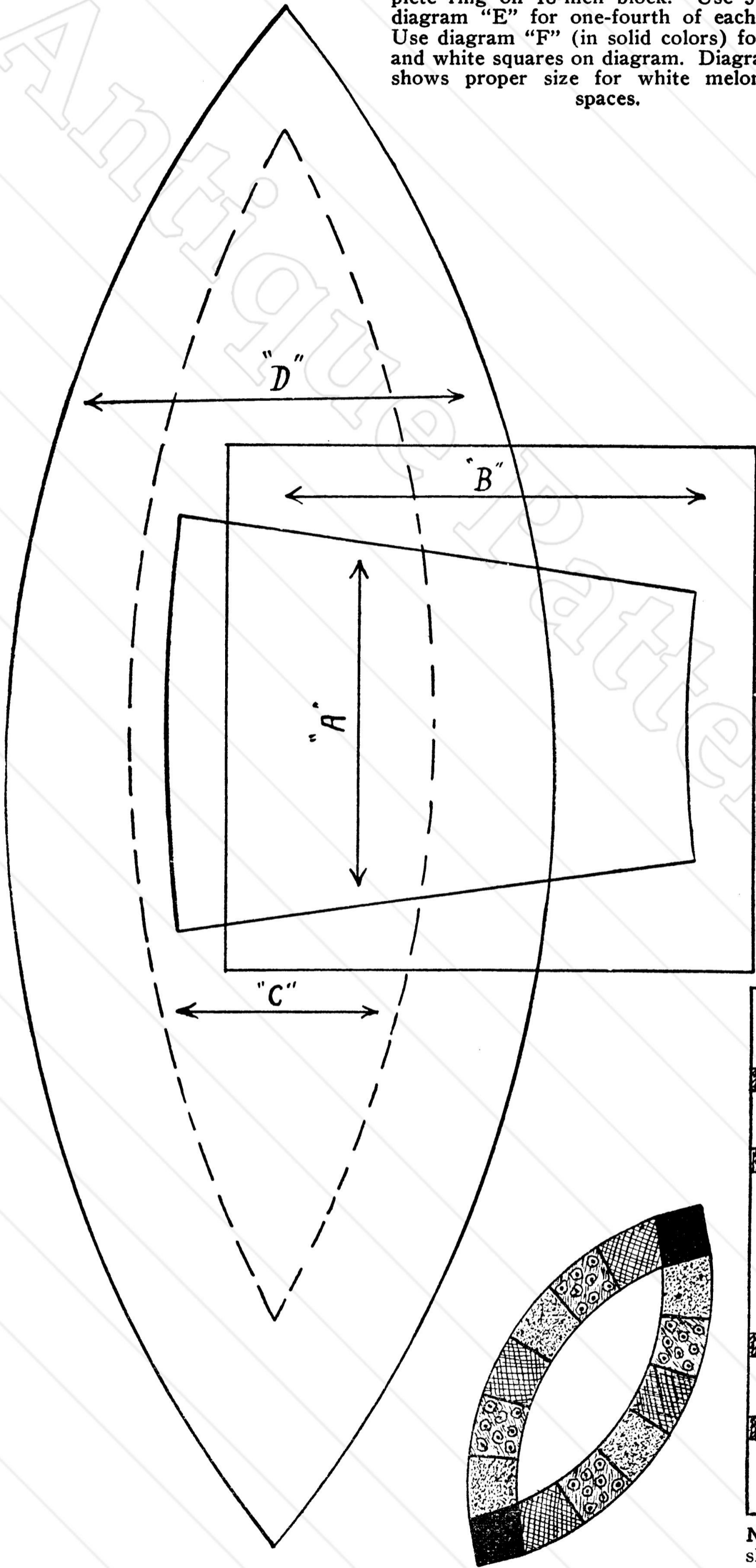

No. 2—Double Wedding Ring. 18-inch block (as shown by dotted lines on above cut). Use 6 pieces of diagram "A" for one-fourth of each circle. Use diagram "B" (in solid colors) for connecting circles. Diagram "D" shows proper size for white melon-shape spaces.

Be sure to allow for seams, as all diagrams for patterns are finished size.

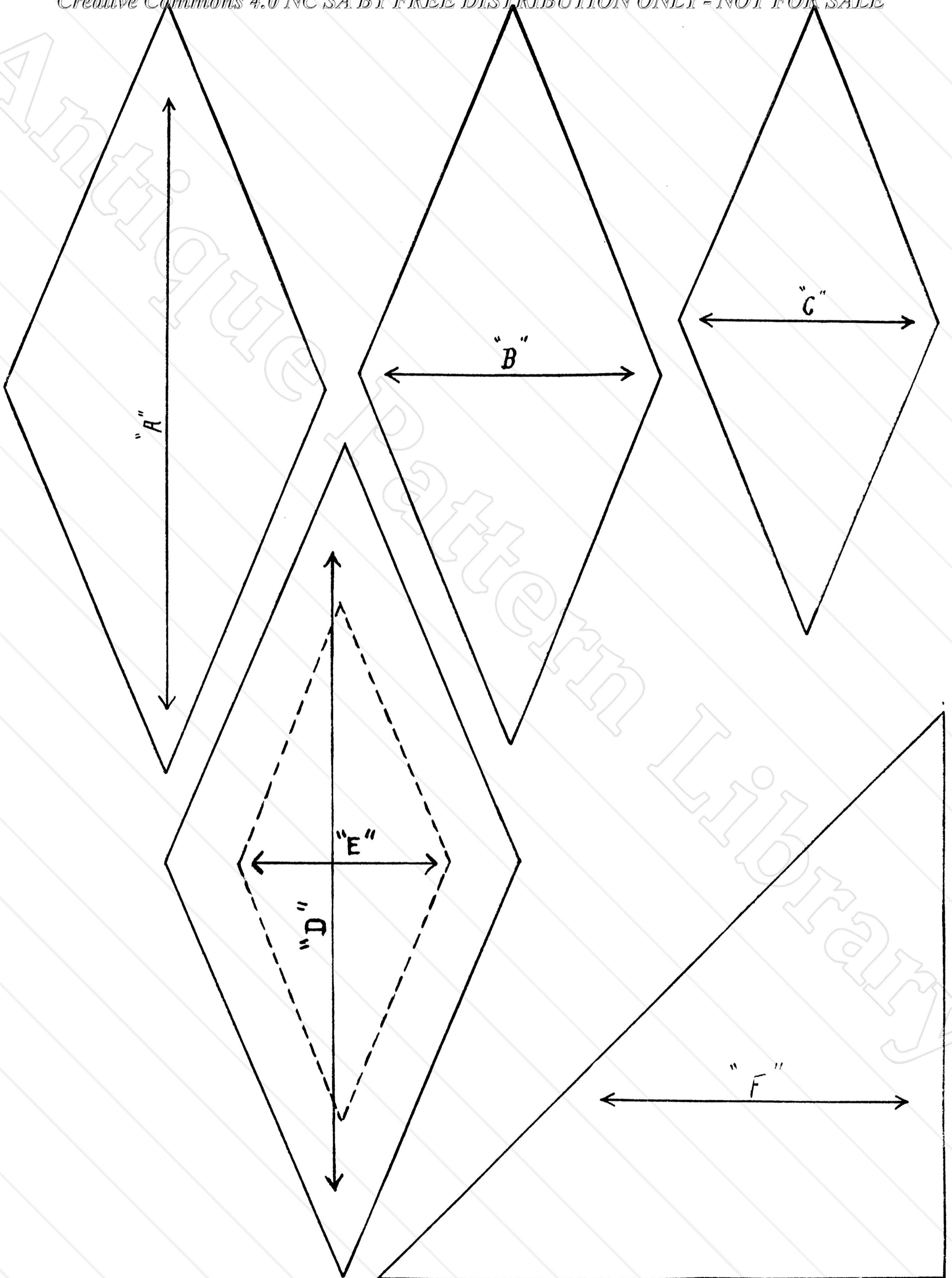

PAGE OF DIAMONDS for designs on page three. Be sure to allow for seams, as all diagrams for patterns are

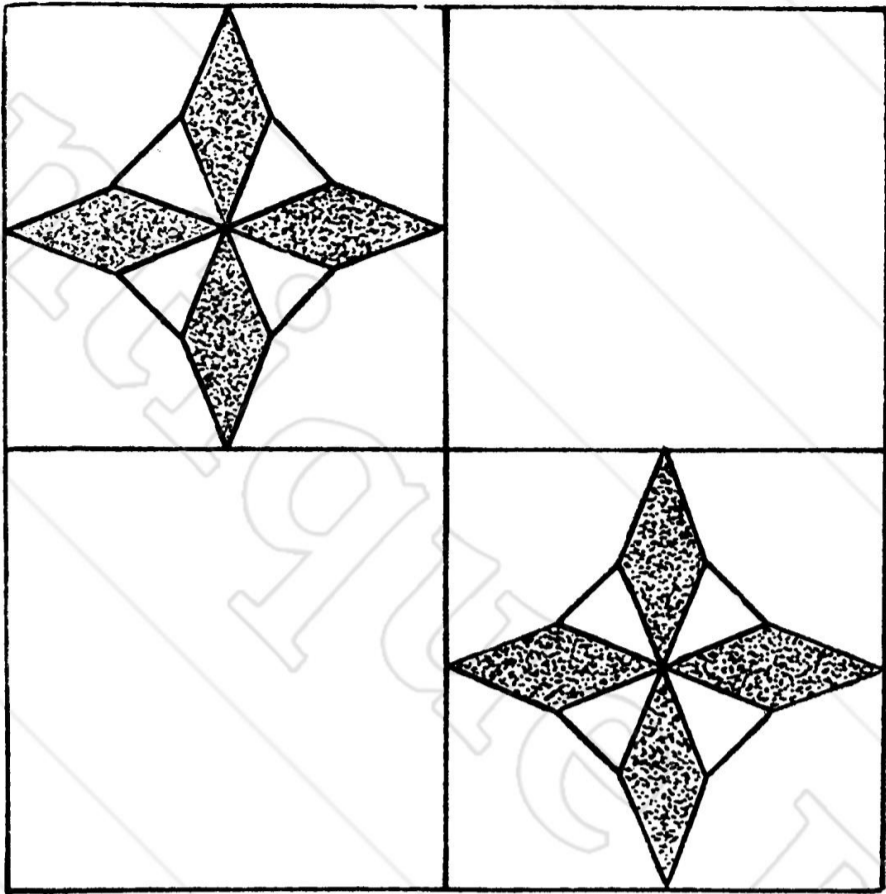

No. 3—Fancy Star. 12-inch block for each star. Use diagram "A" for diamonds. Use half of diagram "A" for triangles.

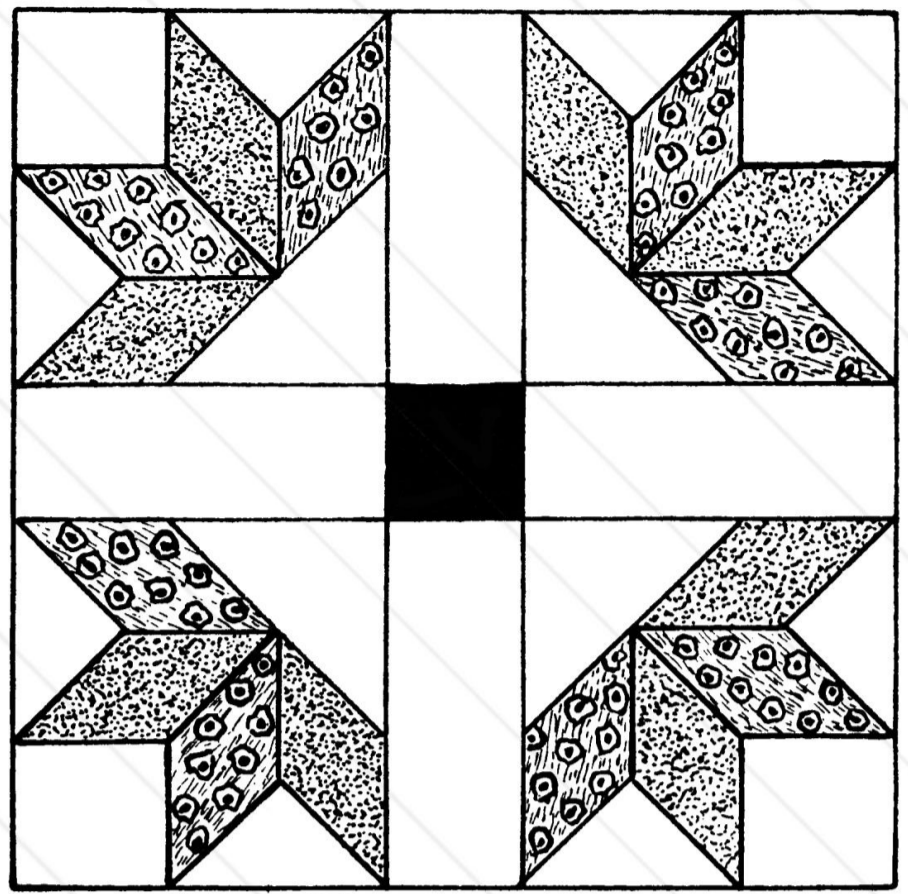

No. 4—Fancy Flowers. 18-inch block complete. Use diagram "B" for diamonds. Use $3\frac{1}{8}$ -inch square in center.

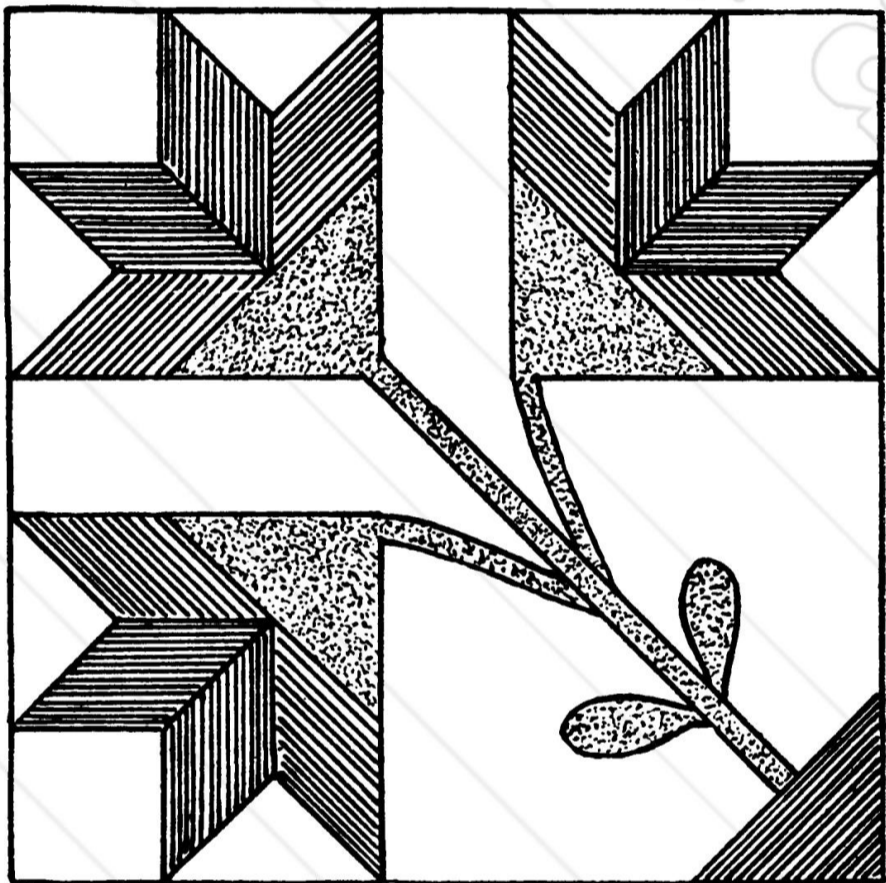

No. 5—Pot of Flowers. 18-inch block complete. Use diagram "B" for diamonds. Use diagram "F" for triangles. Use $\frac{1}{8}$ -inch strip for stems.

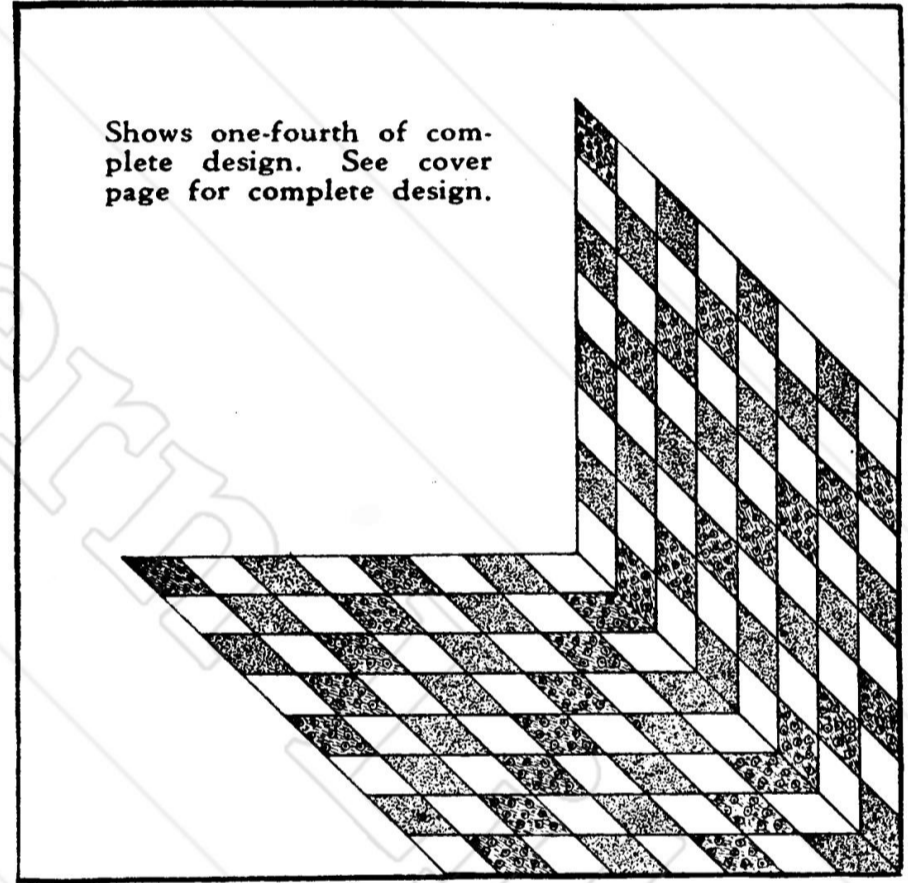

No. 6—Texas Star. Use diagram "E" for diamonds. As shown on cover quilt is 75 x 86.

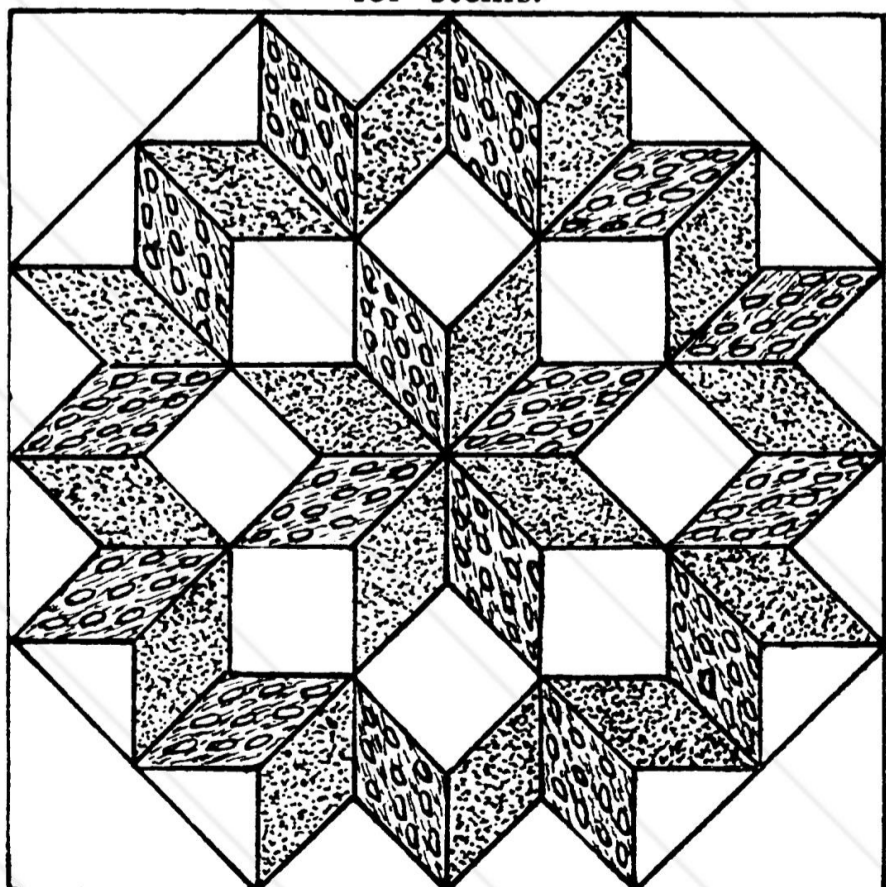

No. 7—Star with Diamonds. 18-inch block. Use diagram "C" for diamonds. Use $2\frac{5}{8}$ -inch squares.

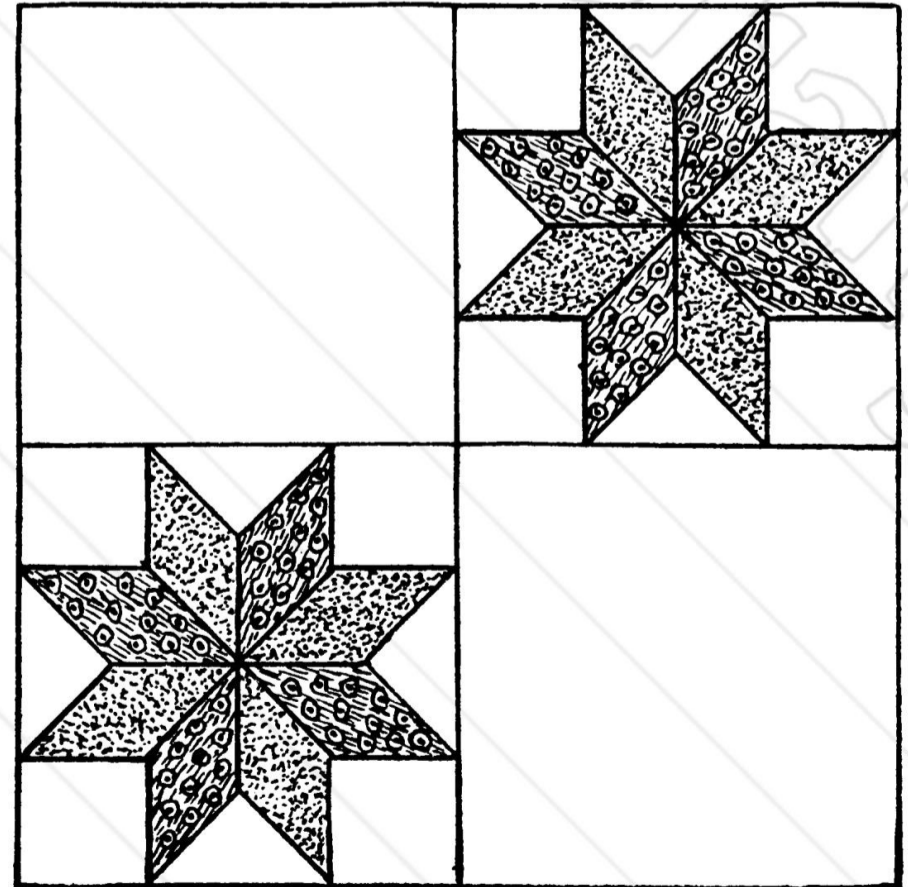

No. 8—Eight-Pointed Star. 12-inch block for each star. Use diagram "D" for diamonds.

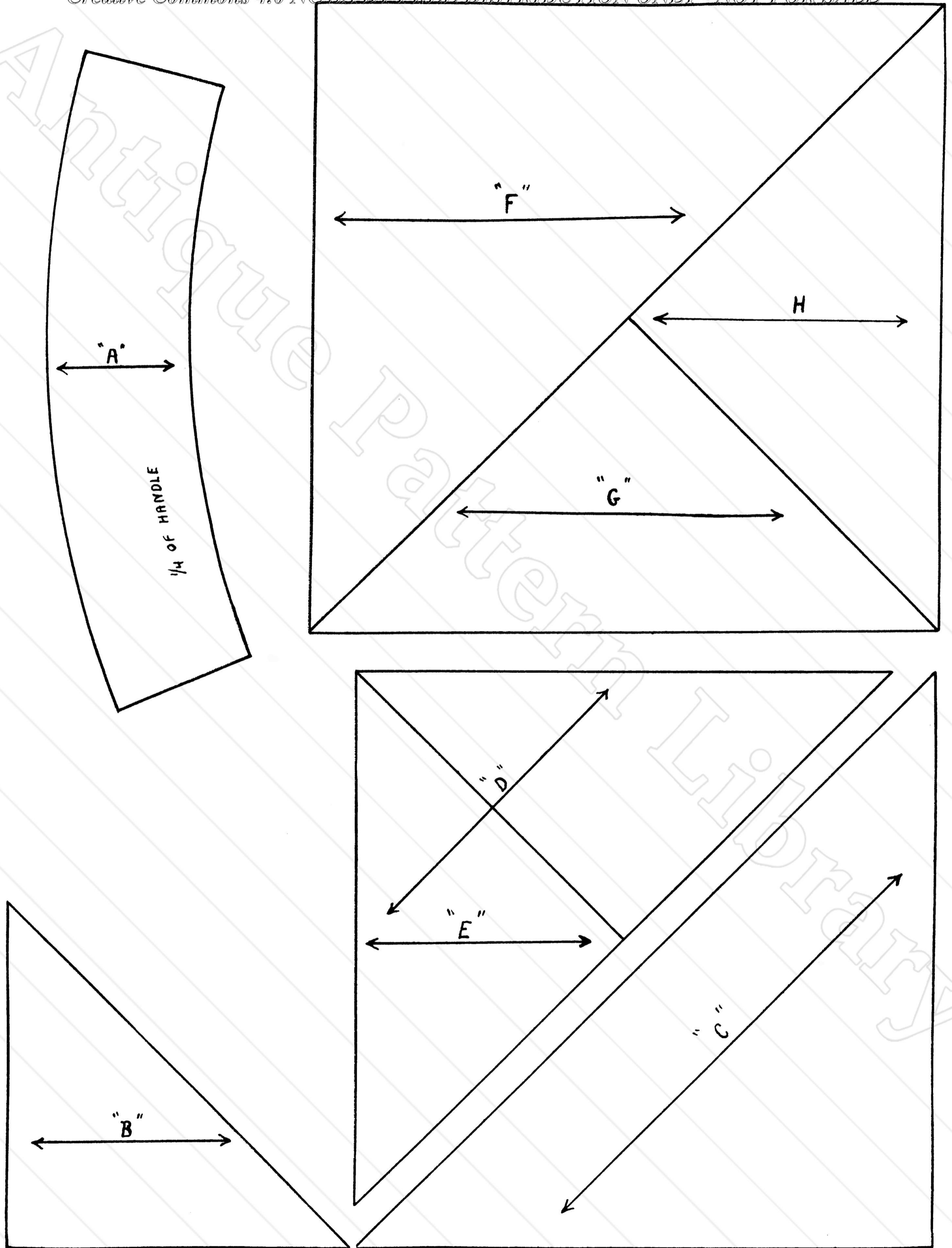

PAGE OF TRIANGLES for designs on page seven. Be sure to allow for seams, as all diagrams for patterns

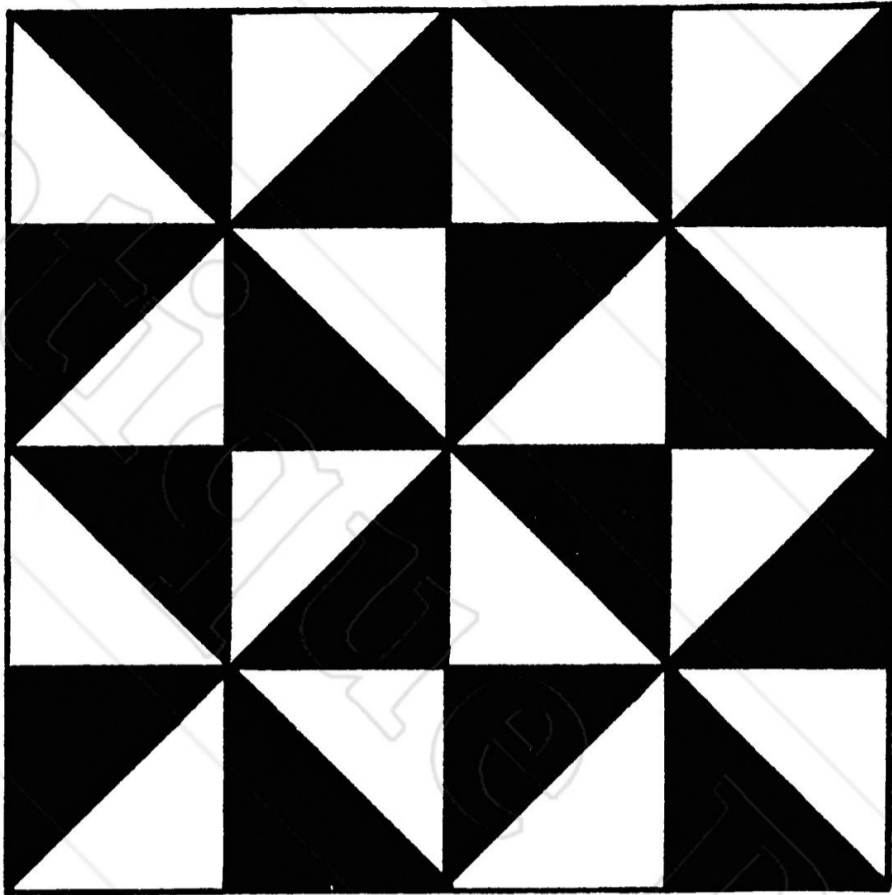

No. 9—Pinwheel. 18-inch block for design as shown. Use diagram "F" for triangles.

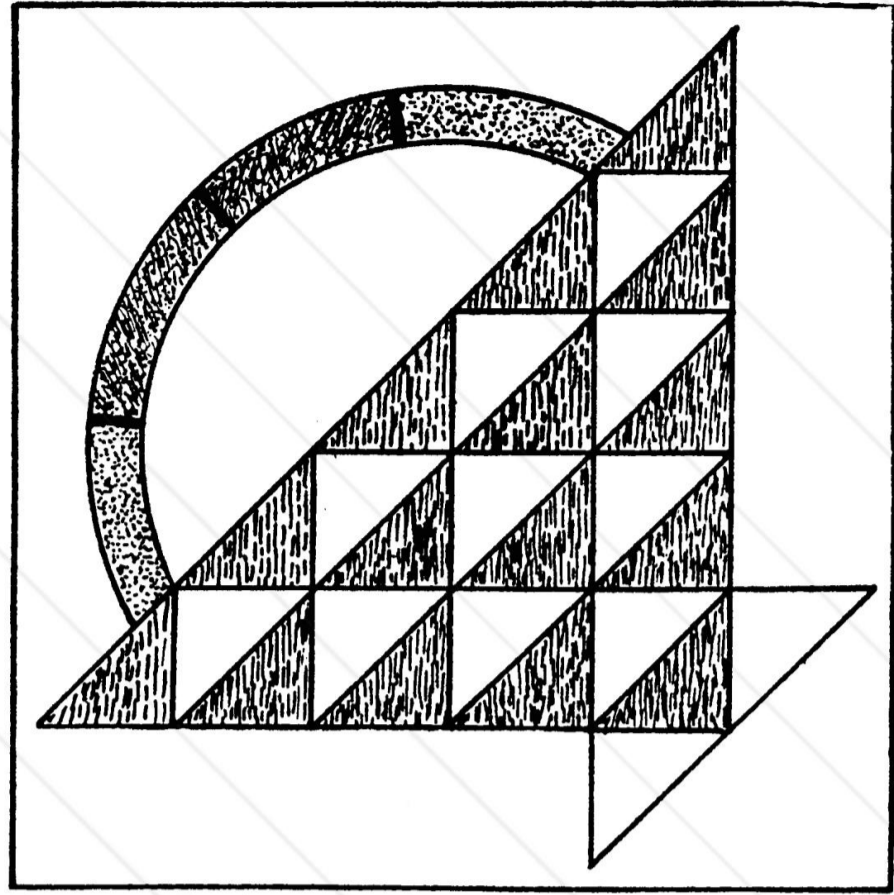

No. 10—Basket. 18-inch block. Use diagram "A" for one-fourth of handle. Use diagram "B" for triangles.

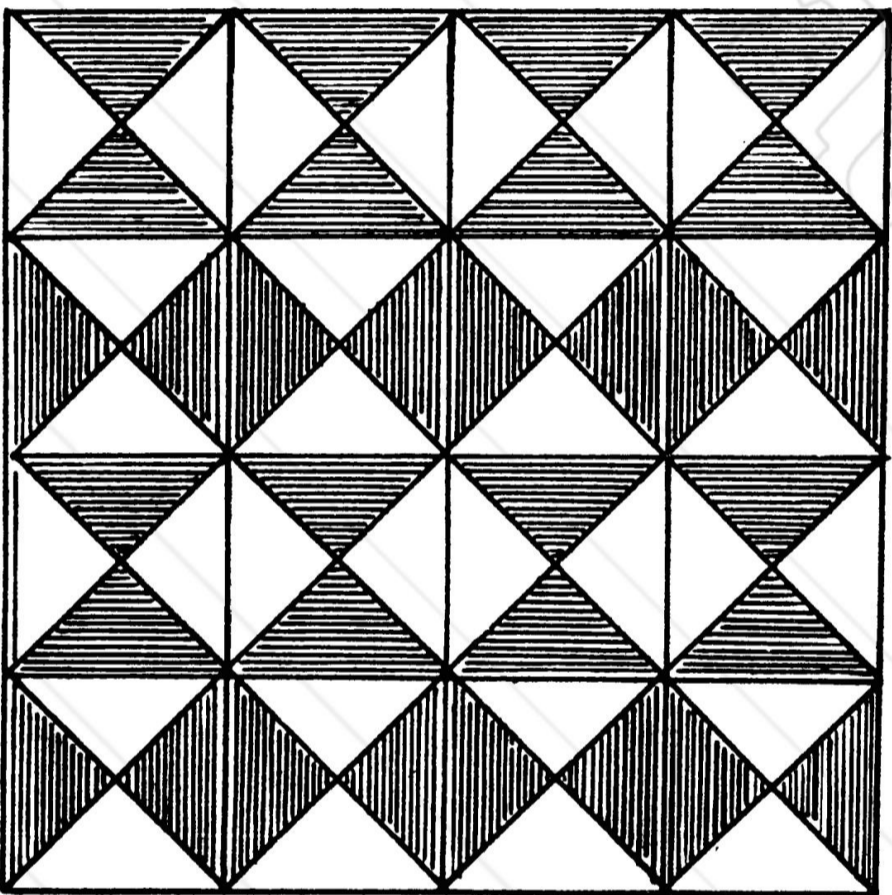

No. 11—Reverse X. 18-inch block for design as shown. Use diagram "G" for large triangles. Use diagram "H" for small triangles.

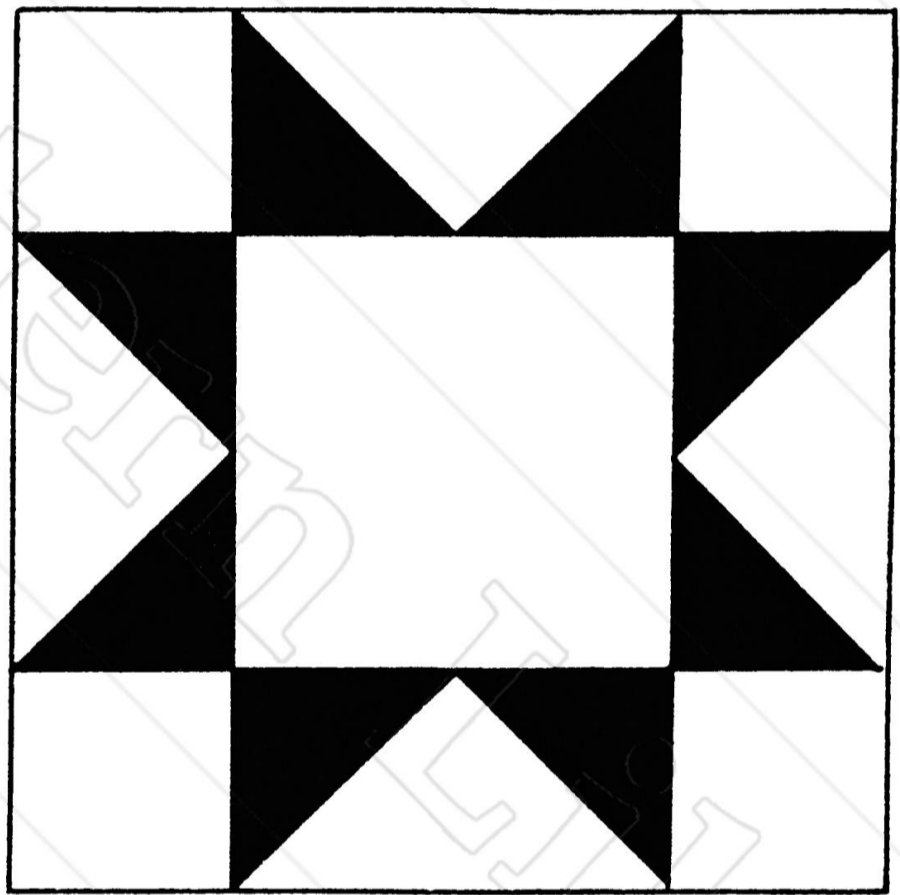

No. 12—Evening Star. 18-inch block. Use diagram "C" for points of star. Use $8\frac{3}{4}$ -inch square for center.

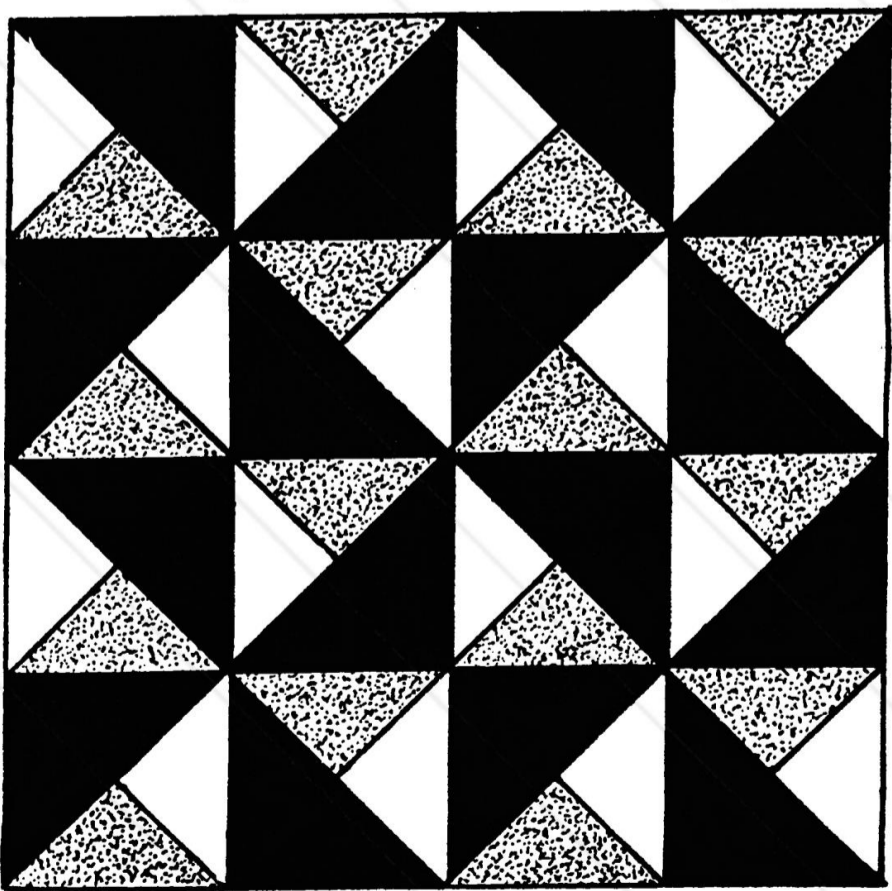

No. 13—Windmill. 18-inch block as shown. Use diagram "F" for large triangles. Use diagram "G" for small triangles.

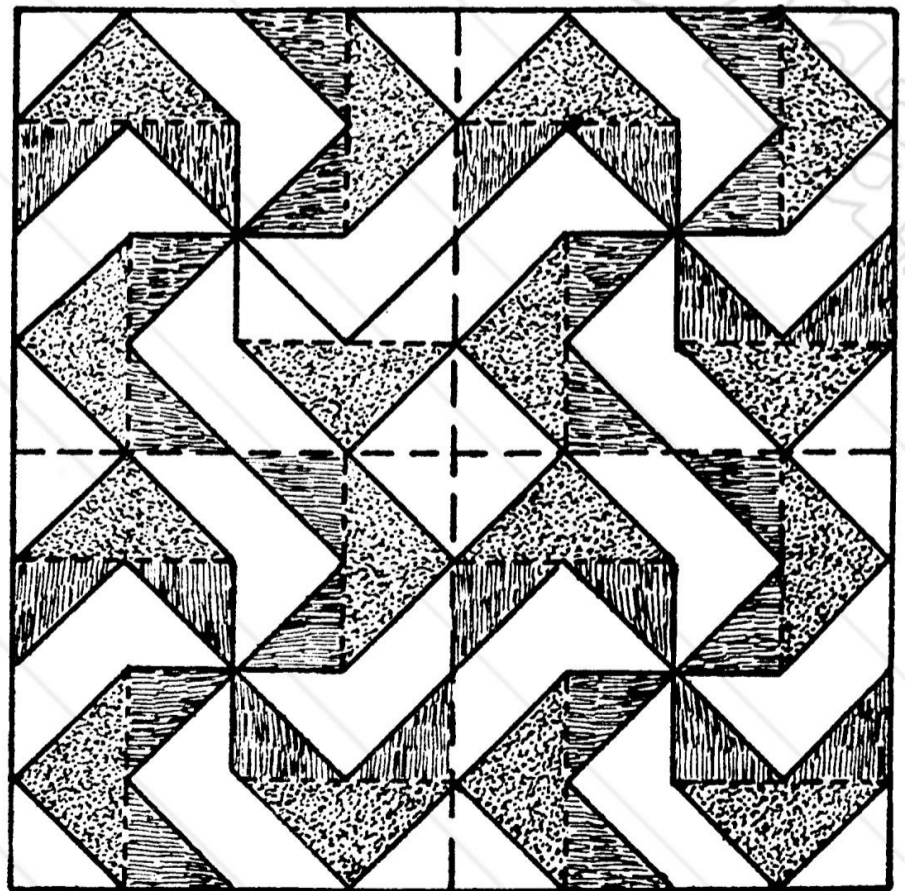

No. 14—Swastika. 24-inch block or four 12-inch blocks. Use diagram "D" for large triangles. Use diagram "E" for small triangles.

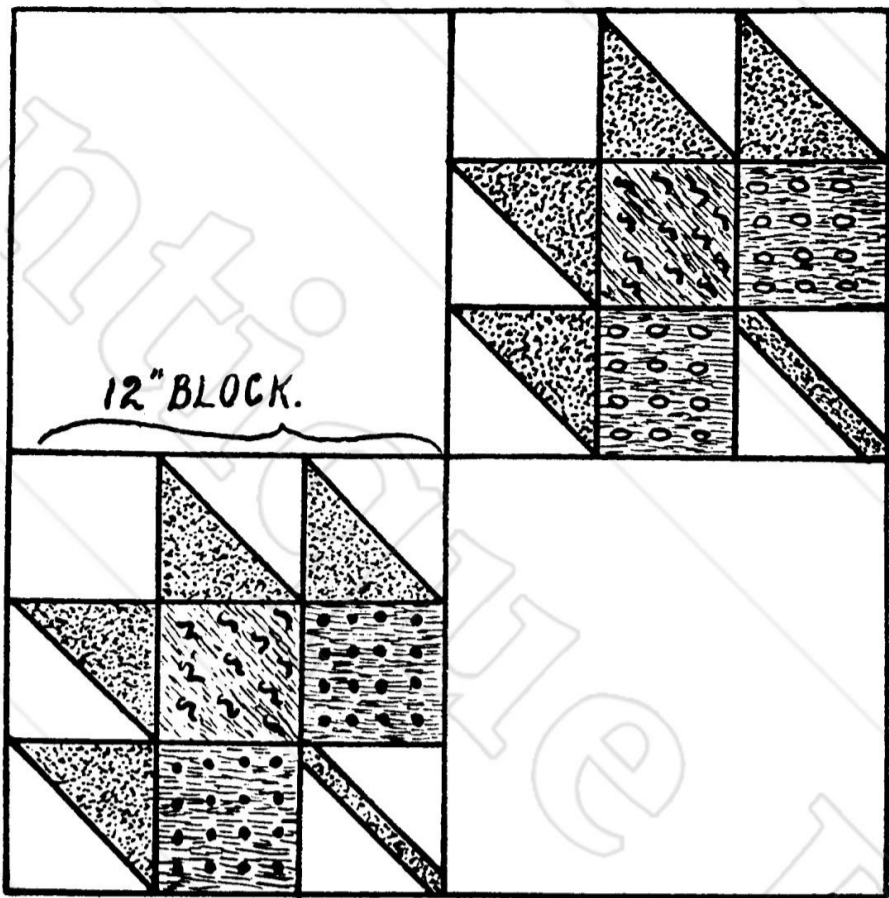

No. 15—Maple Leaf. 12-inch block for each leaf. Use diagram "B" for triangles. Use diagram "C" for squares. Use $\frac{5}{8}$ -inch strip for stem.

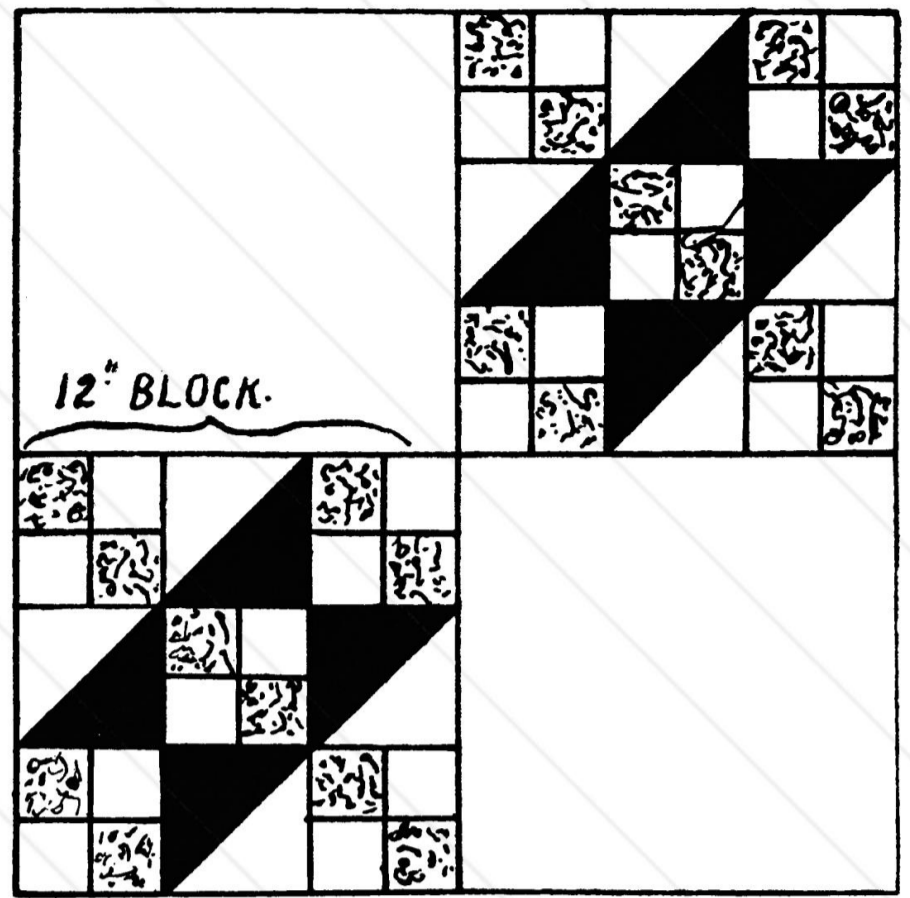

No. 16—Double Hour Glass. 12-inch block for each. Use diagram "A" for squares. Use diagram "B" for triangles.

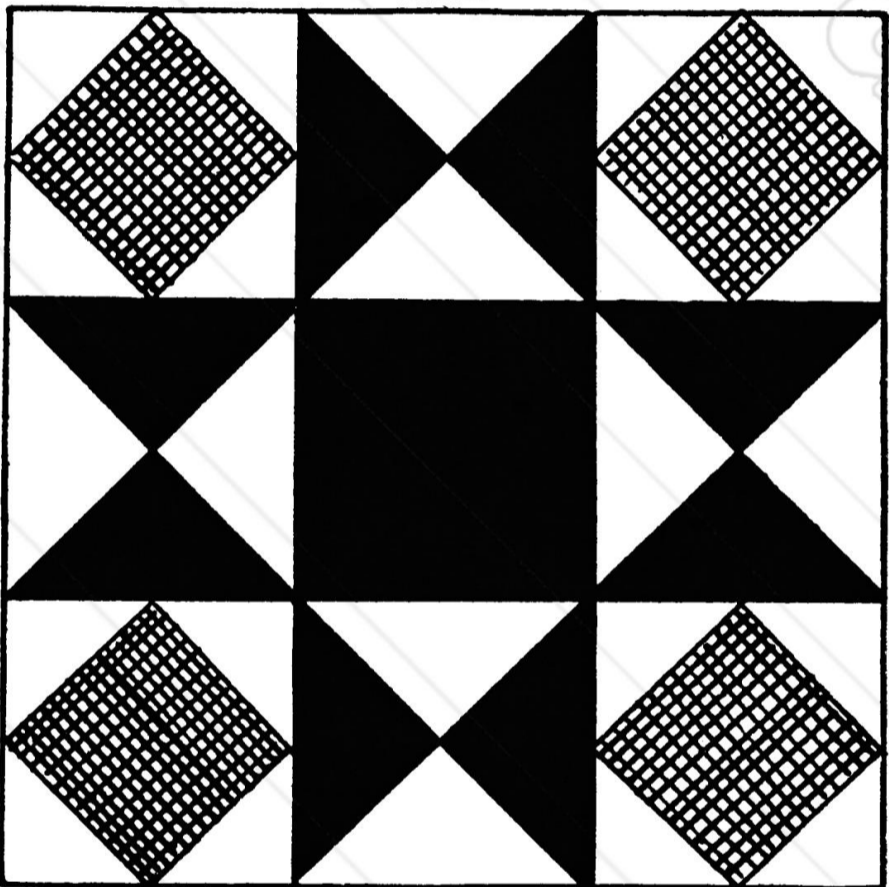

No. 17—Ornate Star—18-inch block. Use diagram "D" for triangles. Use $5\frac{1}{8}$ -inch square in center. Use $4\frac{1}{8}$ -inch squares in corners.

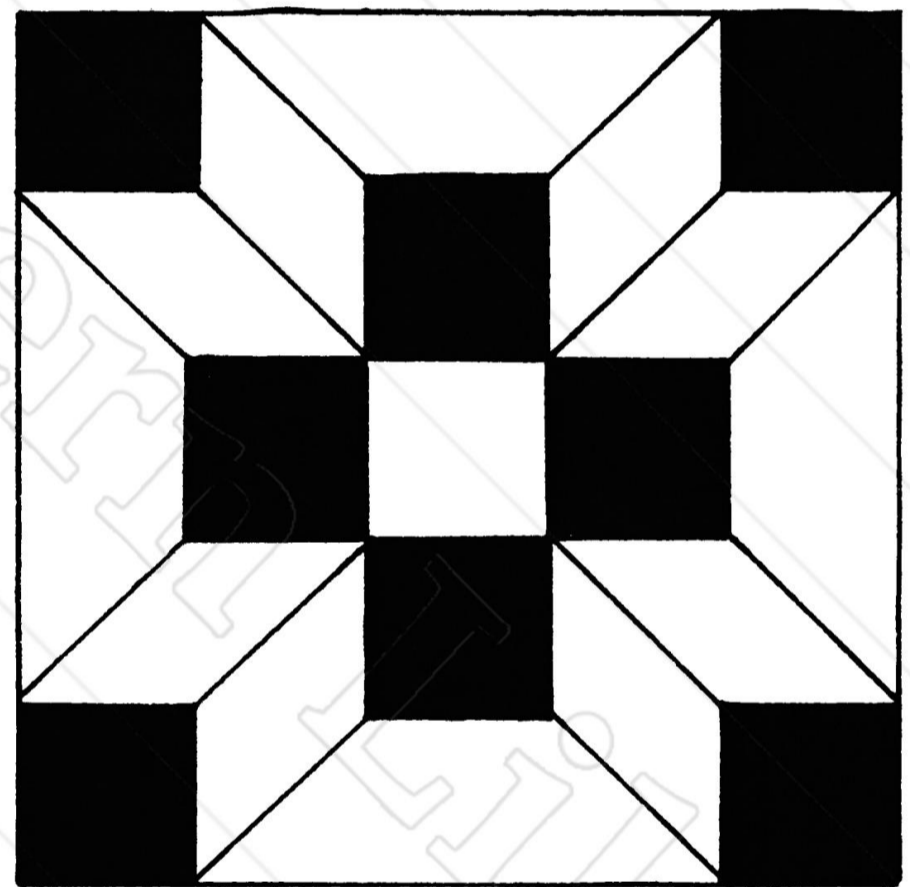

No. 18—Jack's Blocks. 18-inch block. Use $3\frac{1}{2}$ -inch squares.

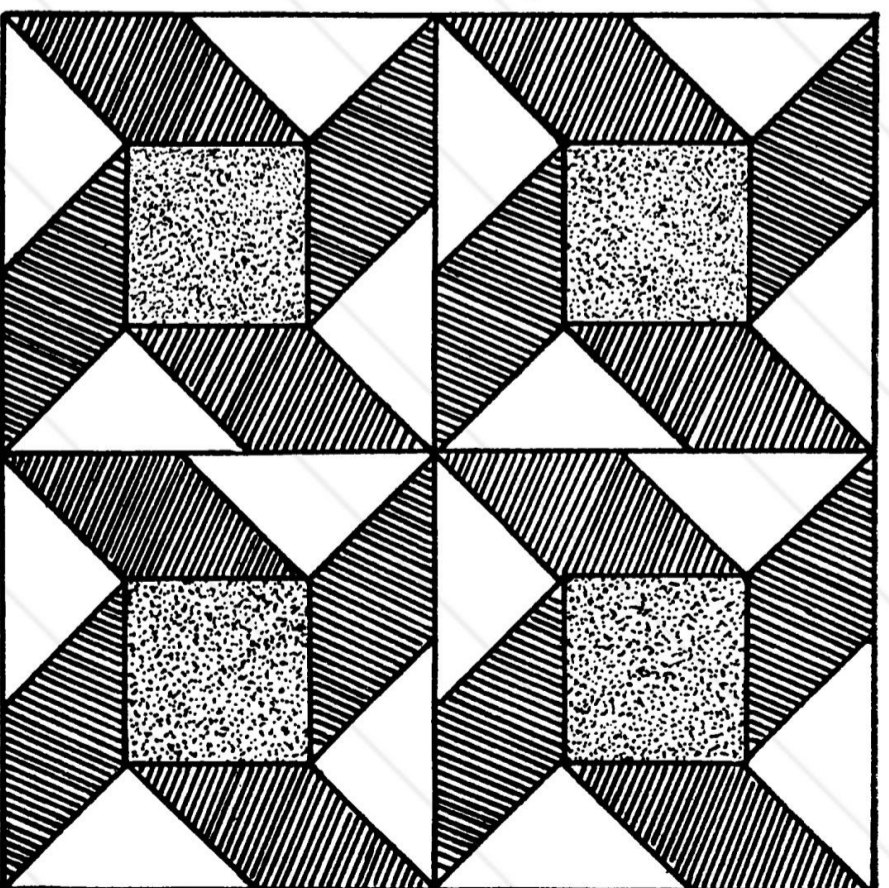

No. 19—Eccentric Star. 12-inch block for each star. Use $4\frac{1}{8}$ -inch square for center. Use diagram "F" (page 6) for white triangles.

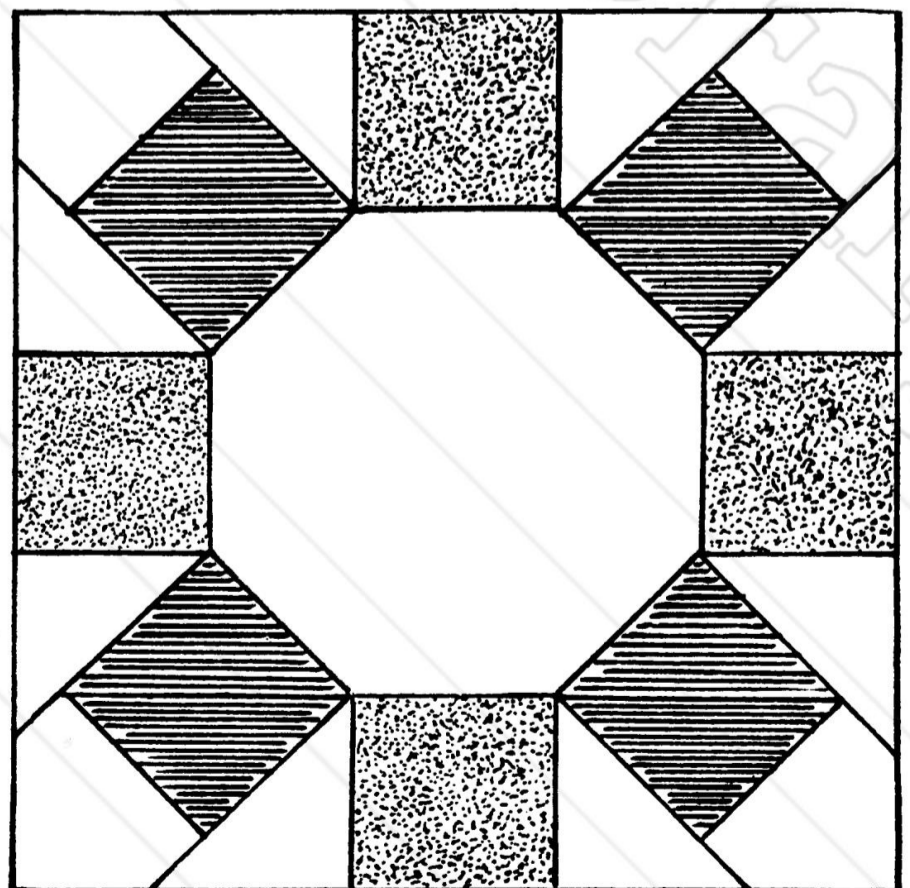

No. 20—Mosaic. 18-inch block. Use $3\frac{1}{8}$ -inch squares.

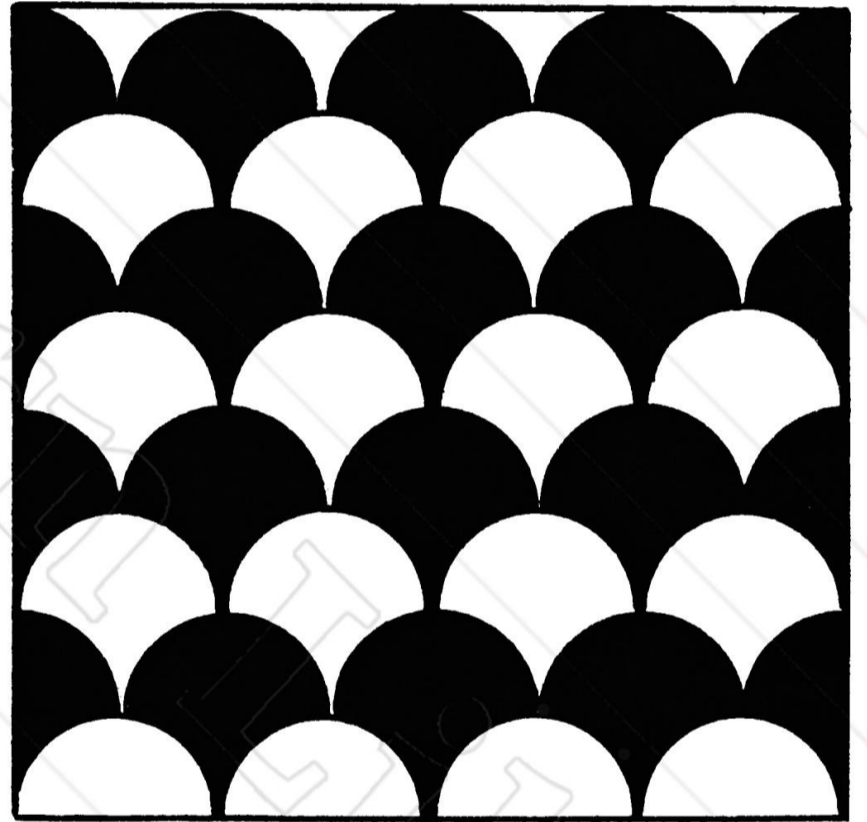
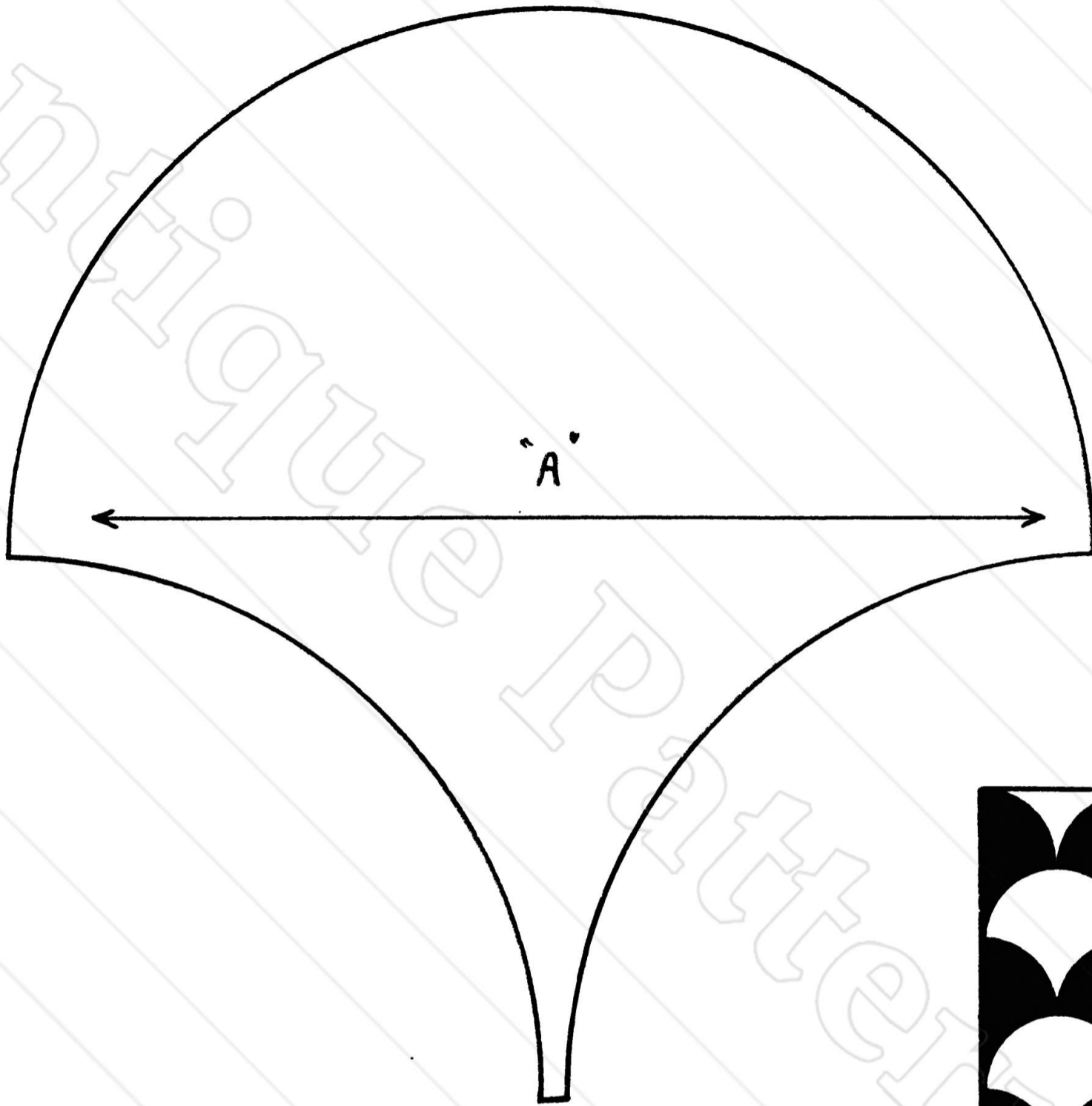

No. 21—Sea Shells. 18-inch block. Use diagram "A".

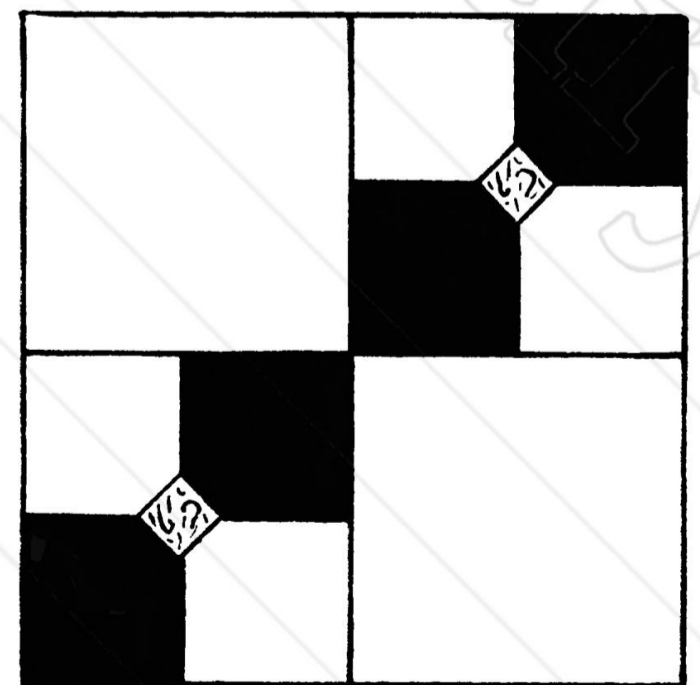
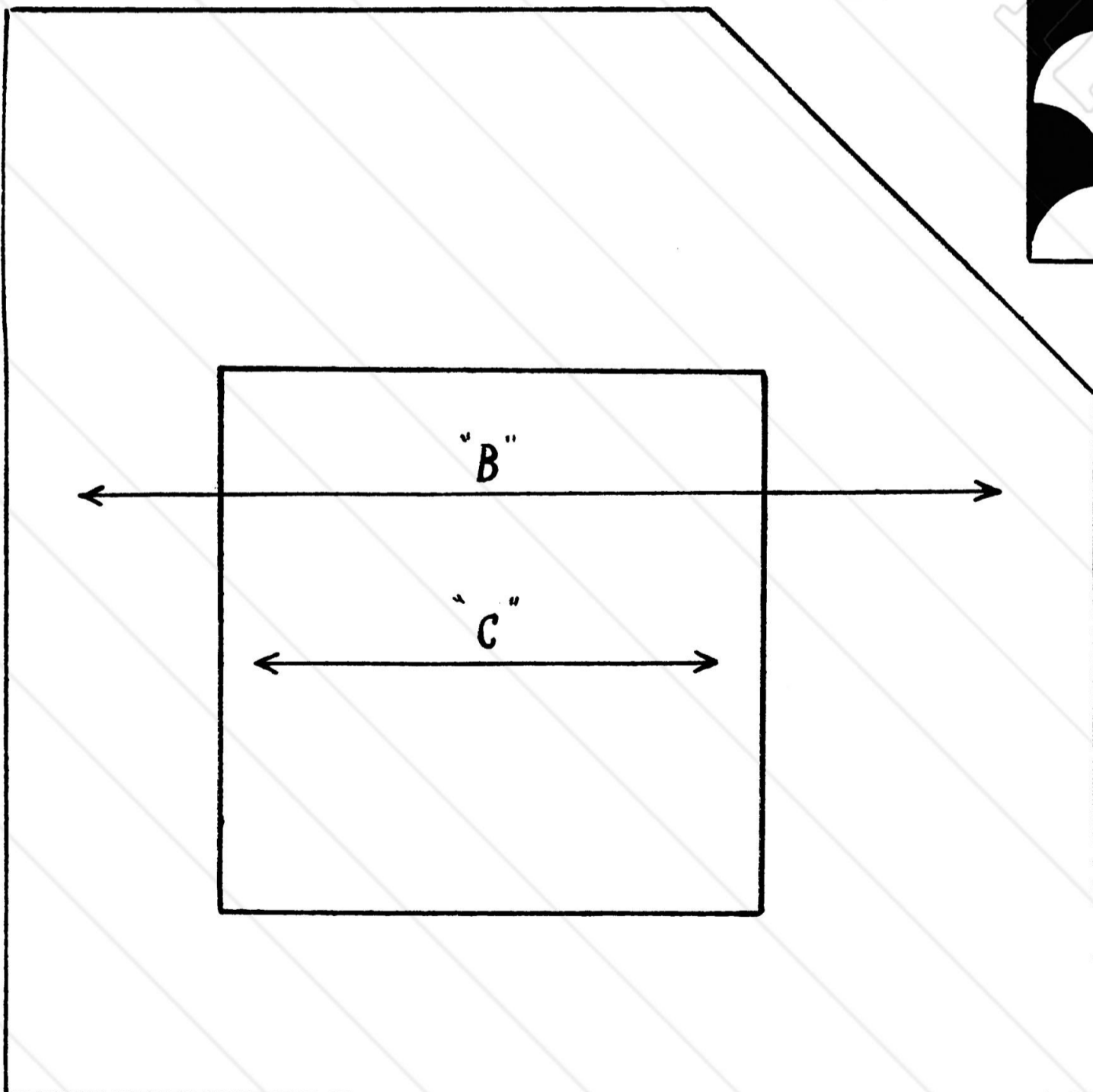

No. 22—Dad's Bow Tie. 9-inch block. Use diagram "B" for sides of tie. Use diagram "C" for center of tie.

No. 23—Grandmother's Fan. 12-inch block for each fan. Use one-fourth of 8-inch diameter circle for corner. Use diagram "A" for points.

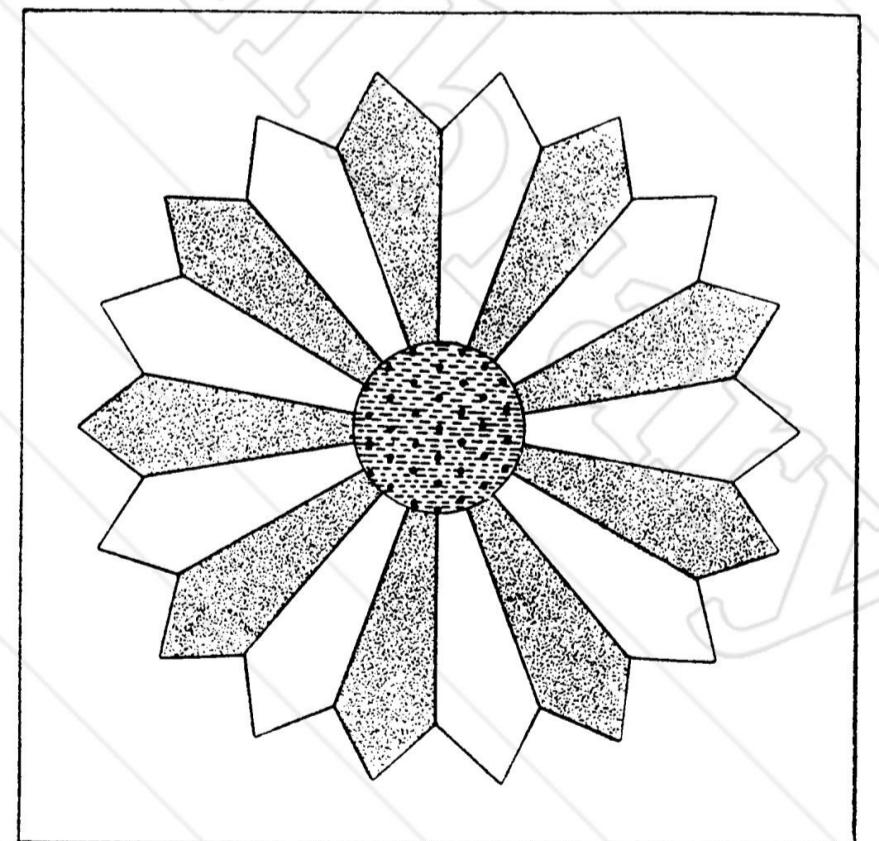
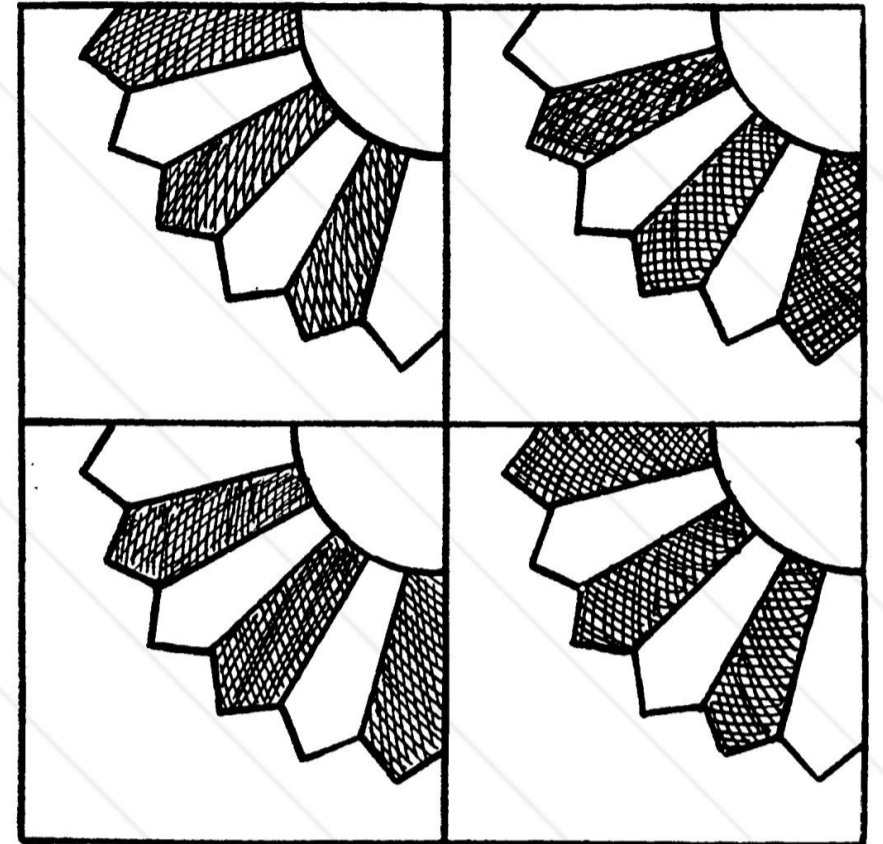
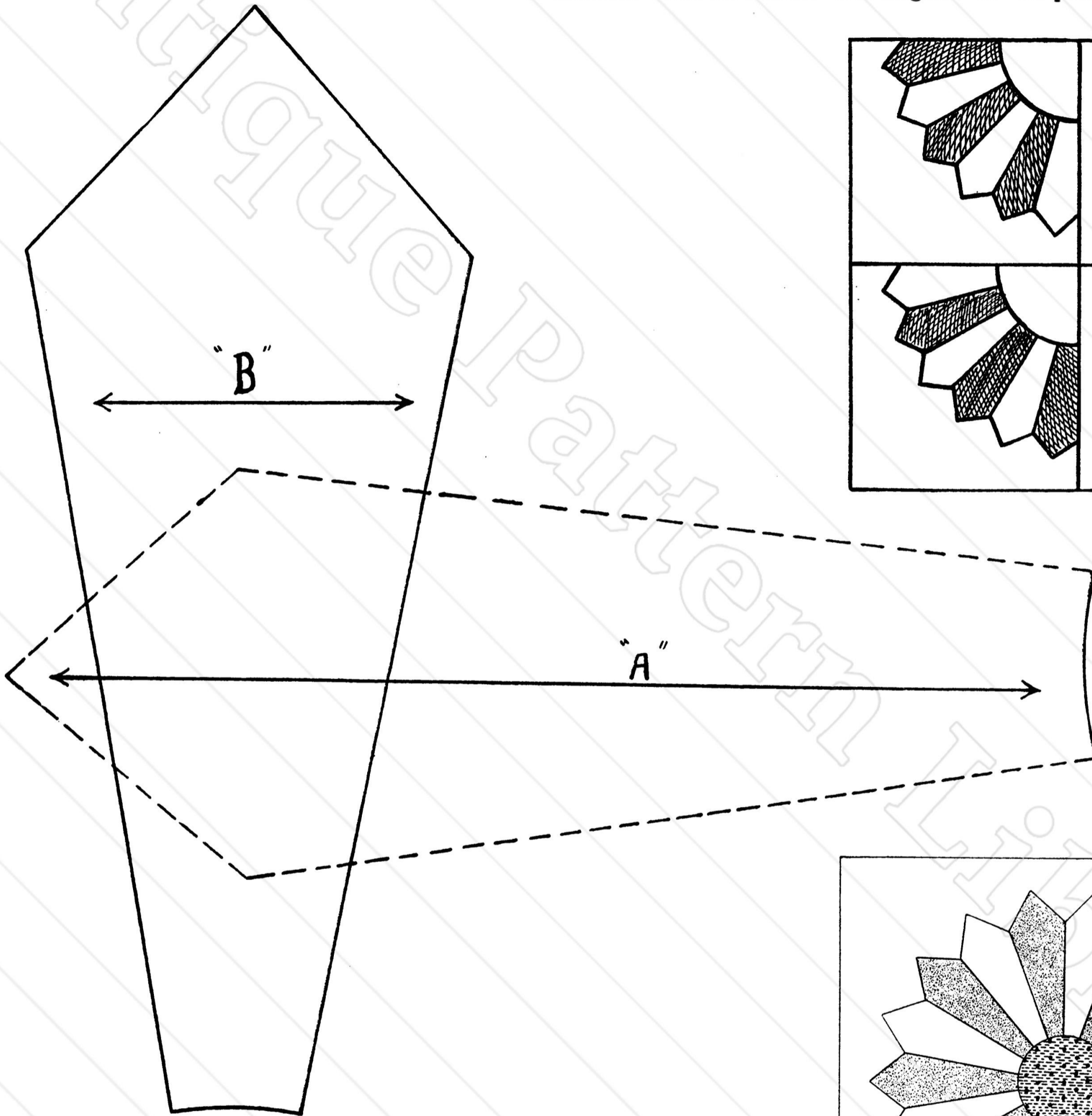

No. 24—Sun Flower. 18-inch block. Use 4-inch diameter circle for center. Use diagram "B" for petals. Called Friendship Ring or Dresden Plate when ends of petals are rounded instead of pointed.

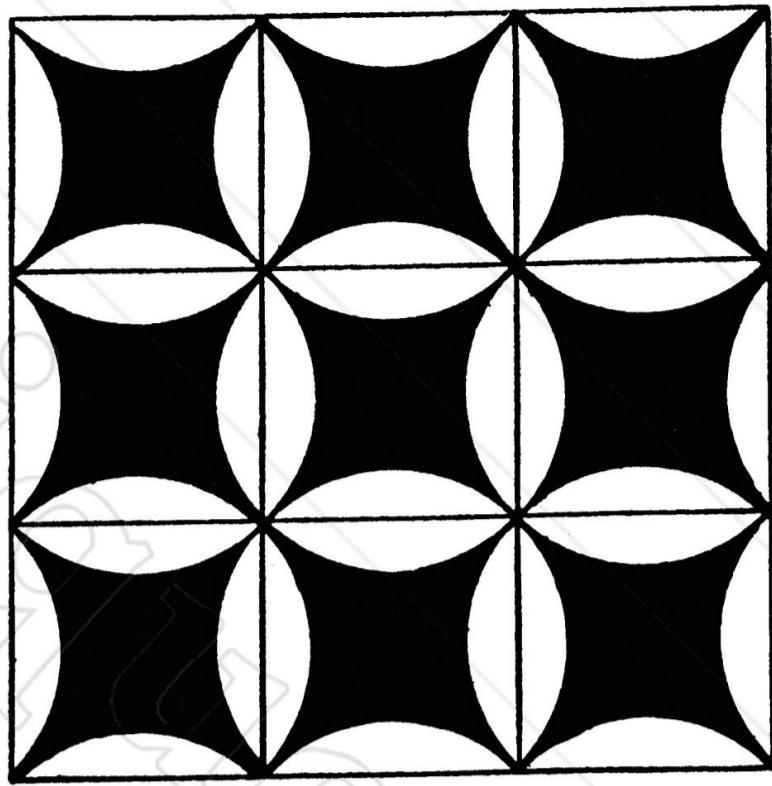

No. 25—Cushion Design. 18-inch block as shown. Use diagram "A" for center. Use half of diagram "B" for sides.

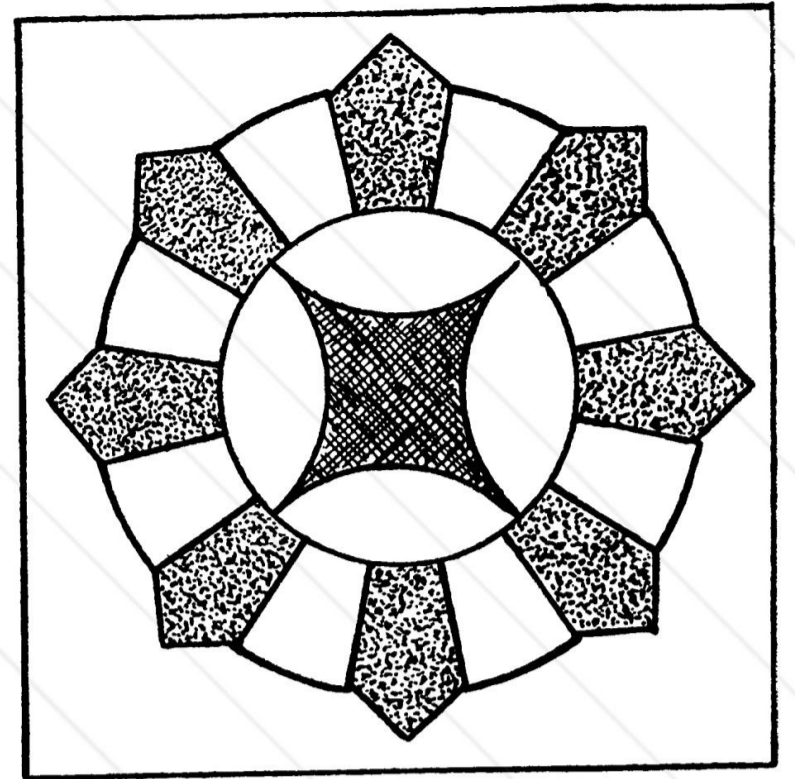

No. 26—Grecian Star. 18-inch block. Use diagram "A" for center. Use diagrams "C" and "D" for parts of star.

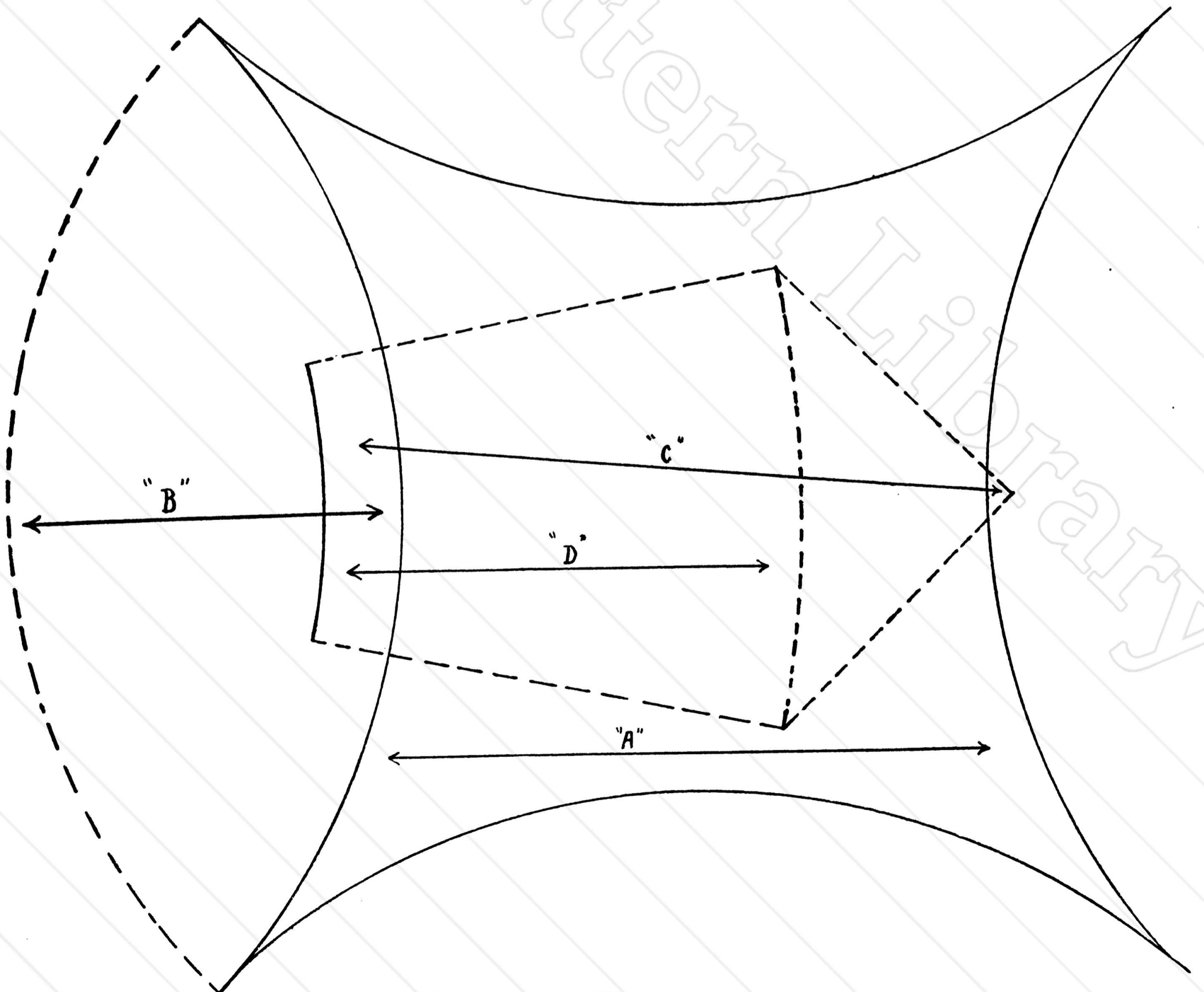

No. 27—Cogwheel. 18-inch block. Use $4\frac{1}{4}$ -inch diameter circle for center. Use diagram "A" for spokes. Use diagram "D" for points.

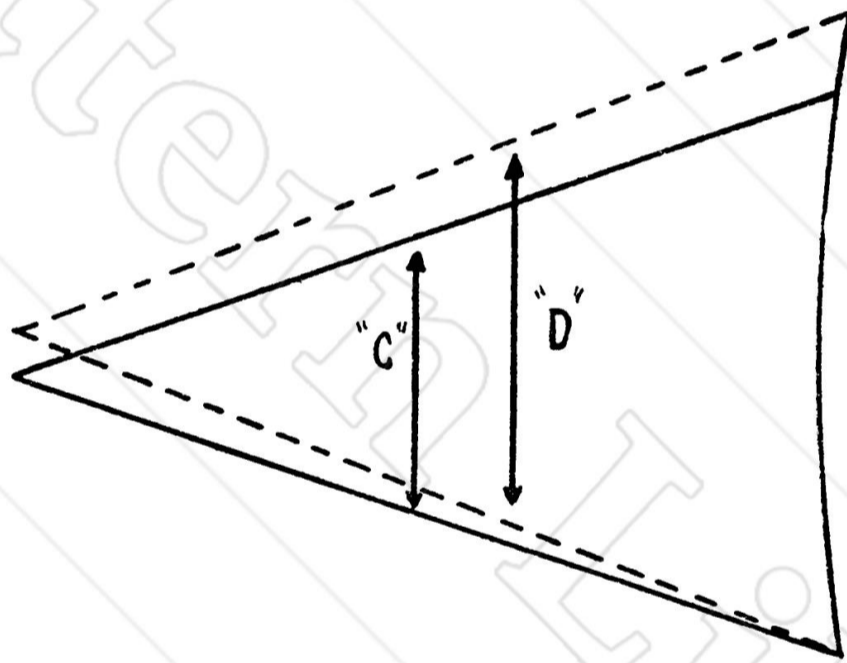
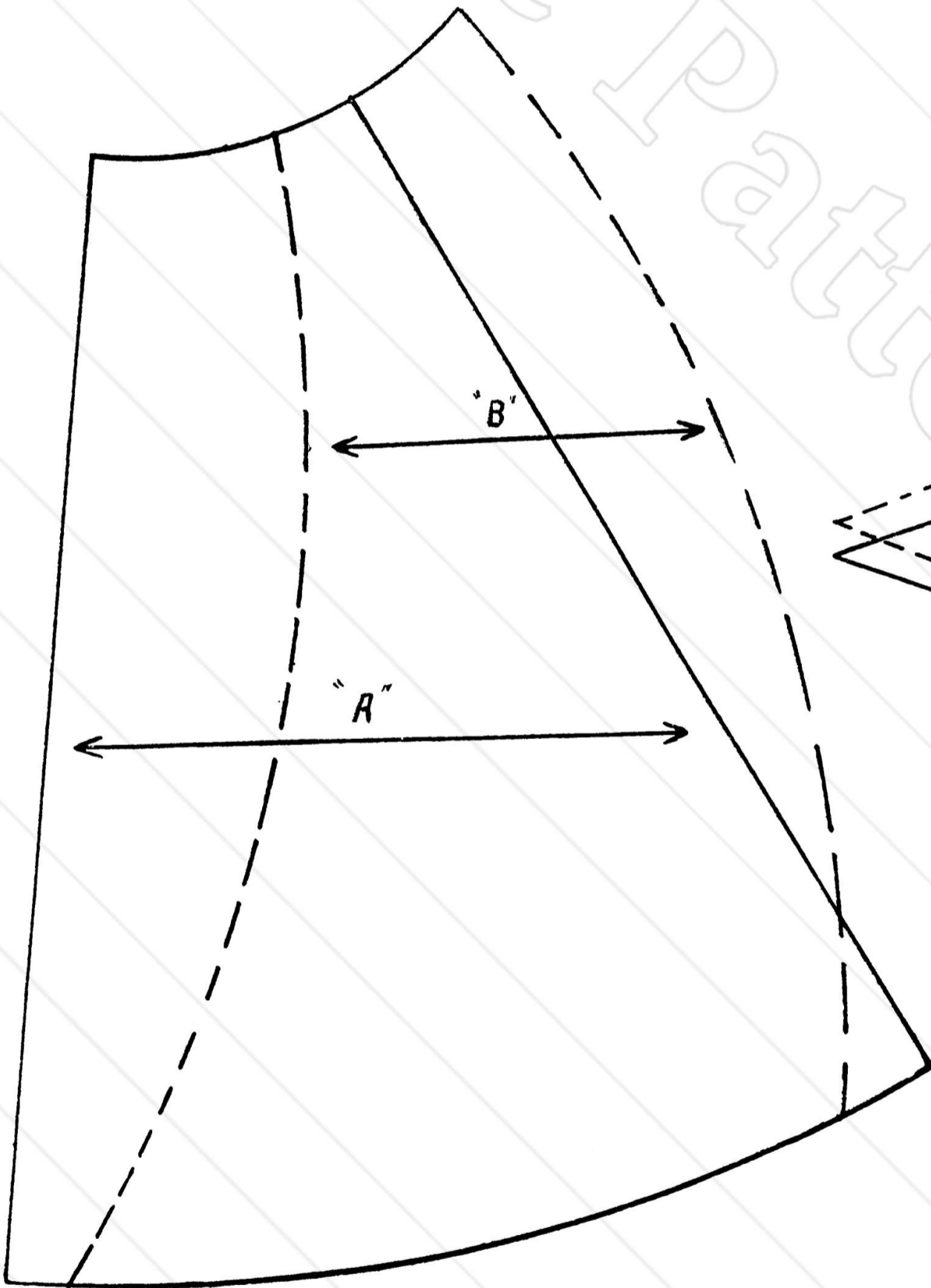
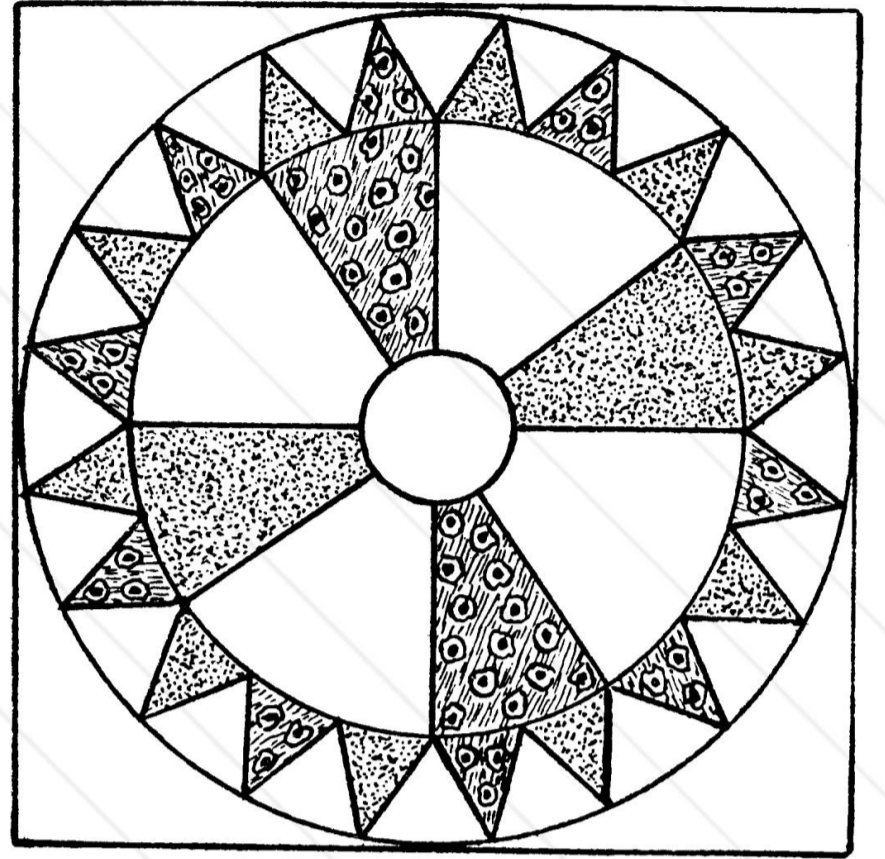

No. 28—Flywheel. 18-inch block. $4\frac{1}{4}$ -inch diameter circle for center. Use diagram "B" for spokes. Use diagram "C" for points.

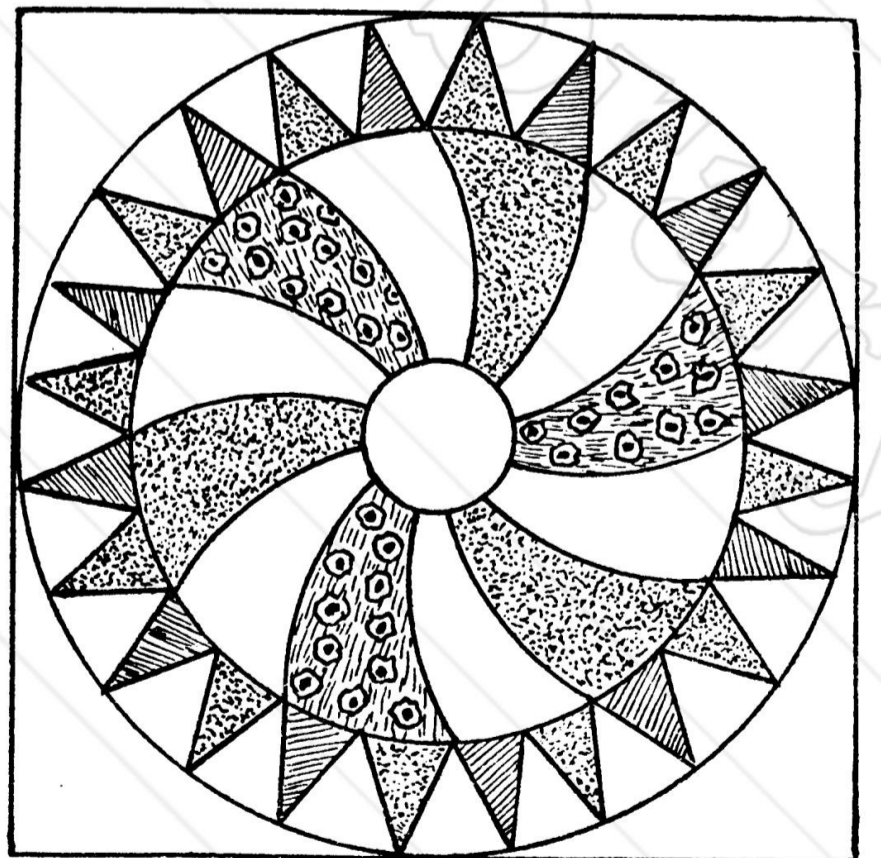

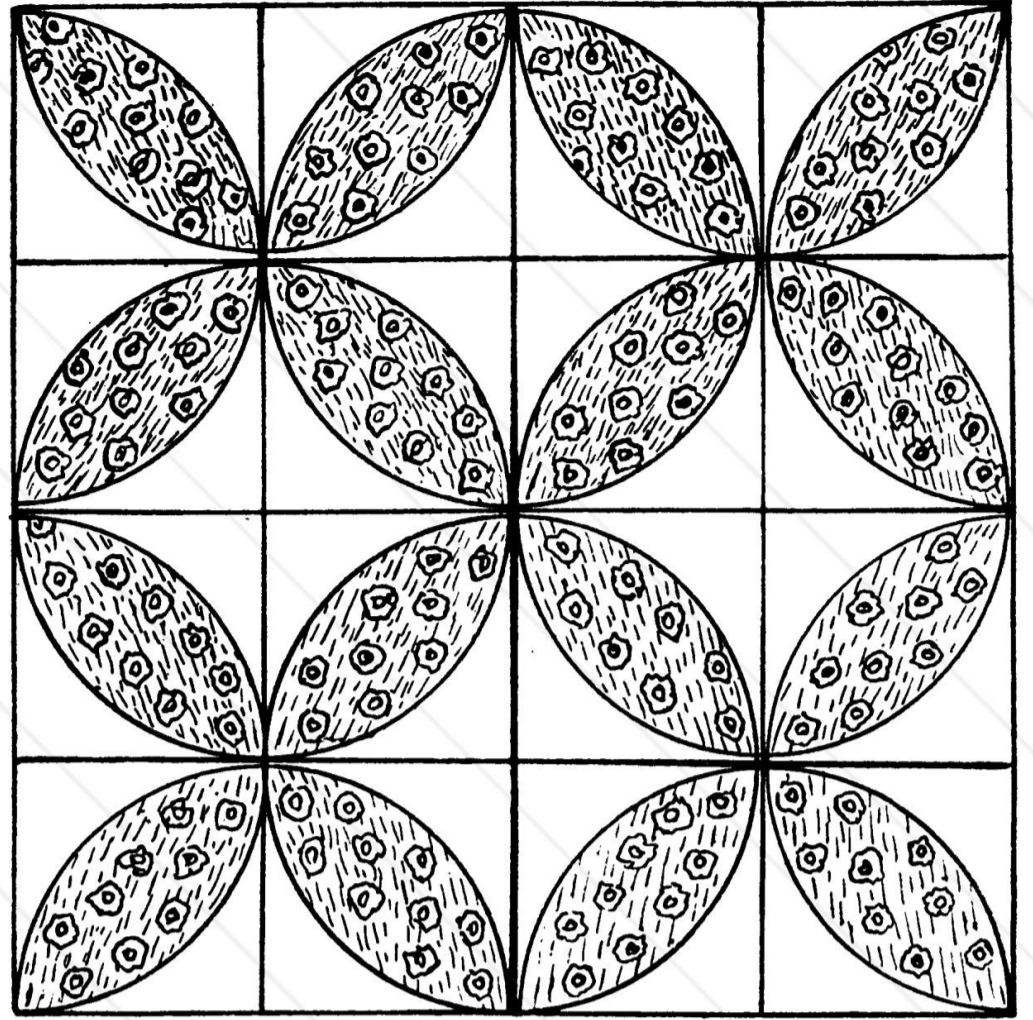
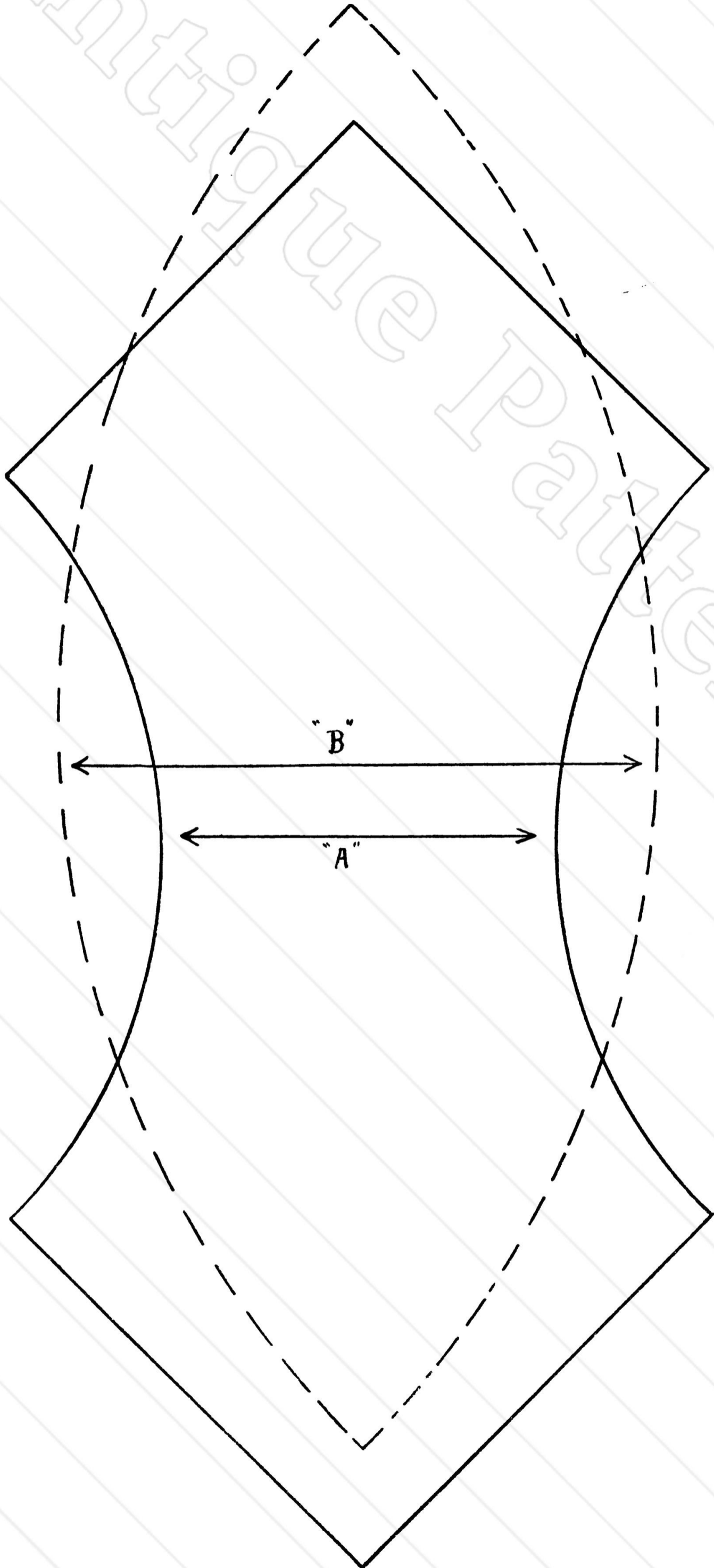

No. 29—Orange Peel. Use diagram "B" for peels 12-inch block. (Above sketch shows four 12-inch blocks.) Four Peels to one 12-inch block.

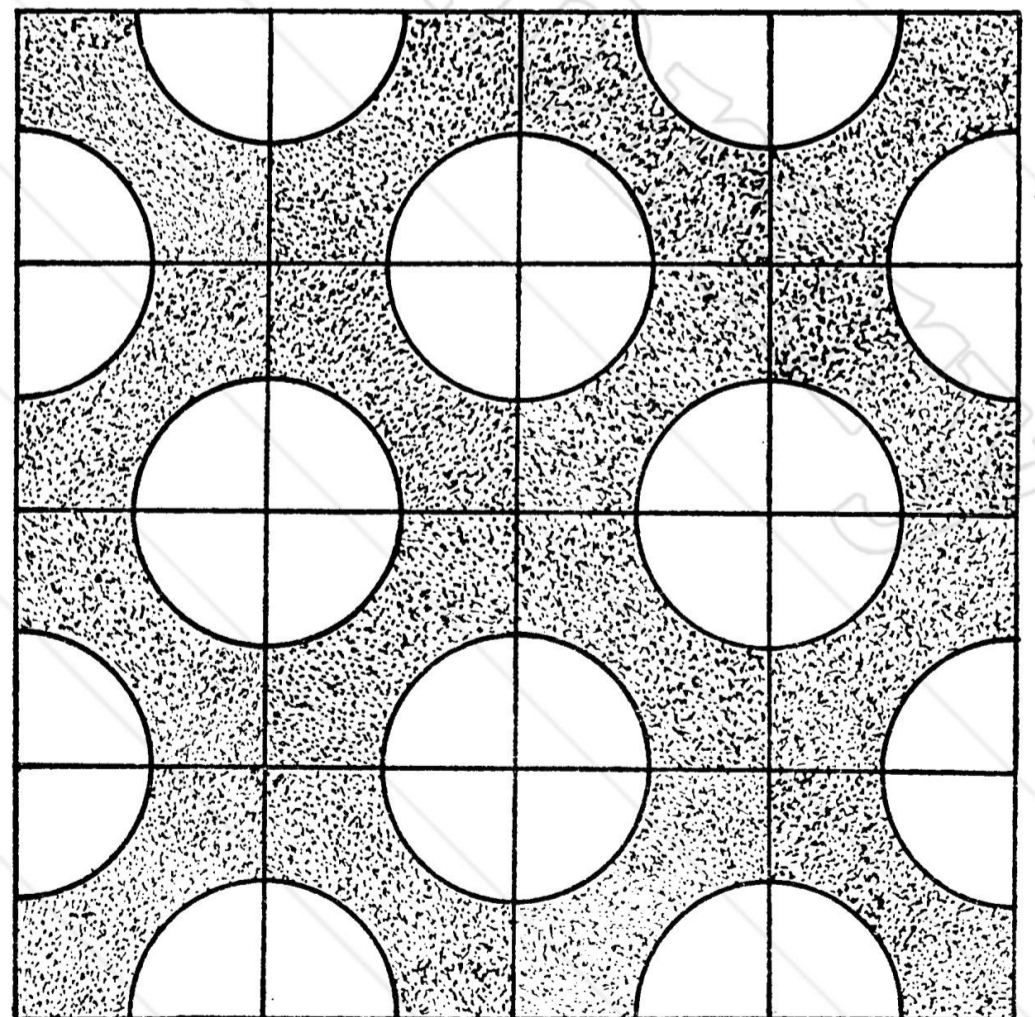

No. 30—Circle Design. 12-inch blocks. Use diagram "A" and one-fourth of 6-inch diameter circle. (Above sketch shows four 12-inch blocks.)

POPULAR WAYS OF SETTING QUILT BLOCKS TOGETHER

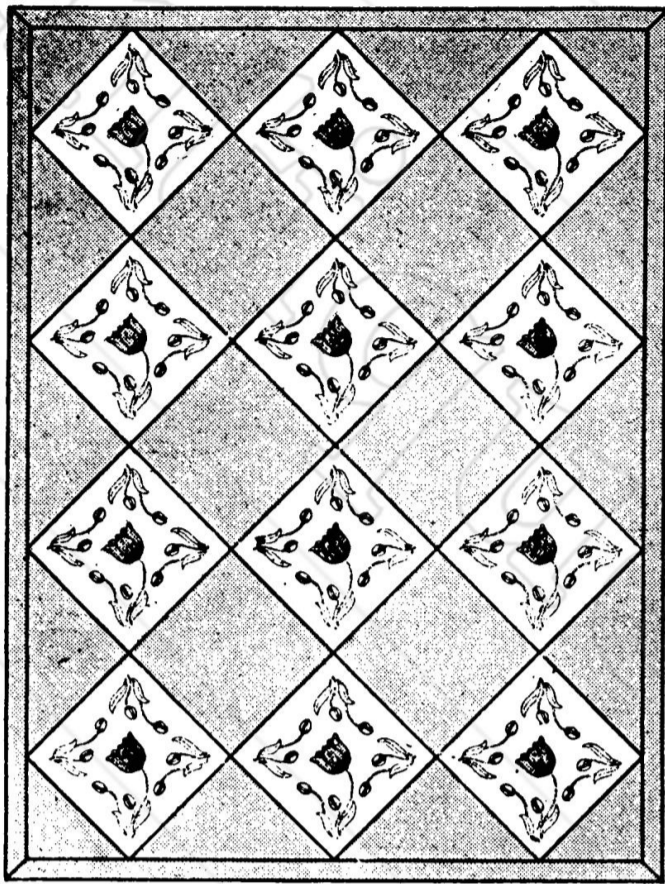

18-inch Blocks

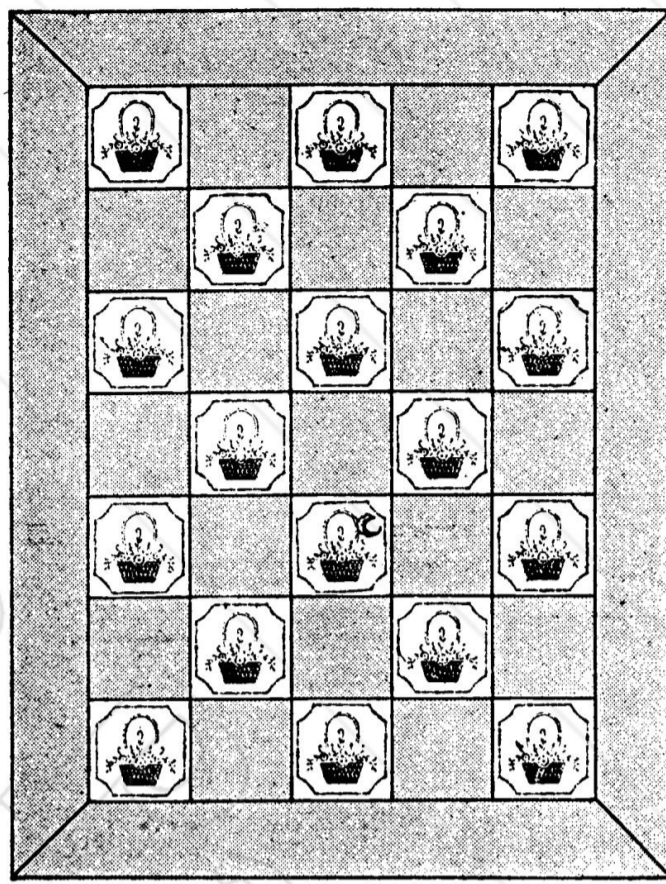

12-inch Blocks

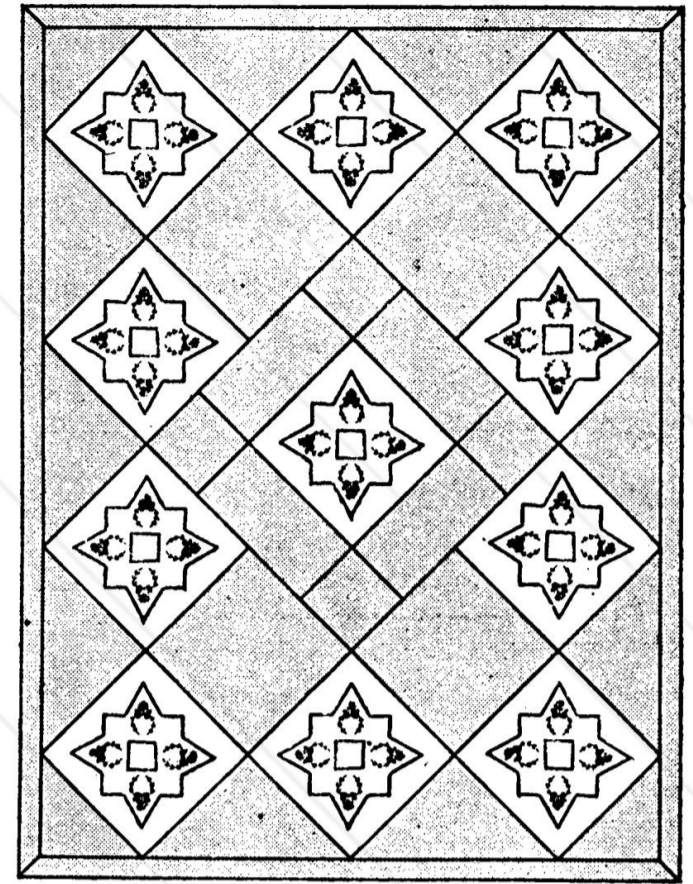

18-inch Blocks

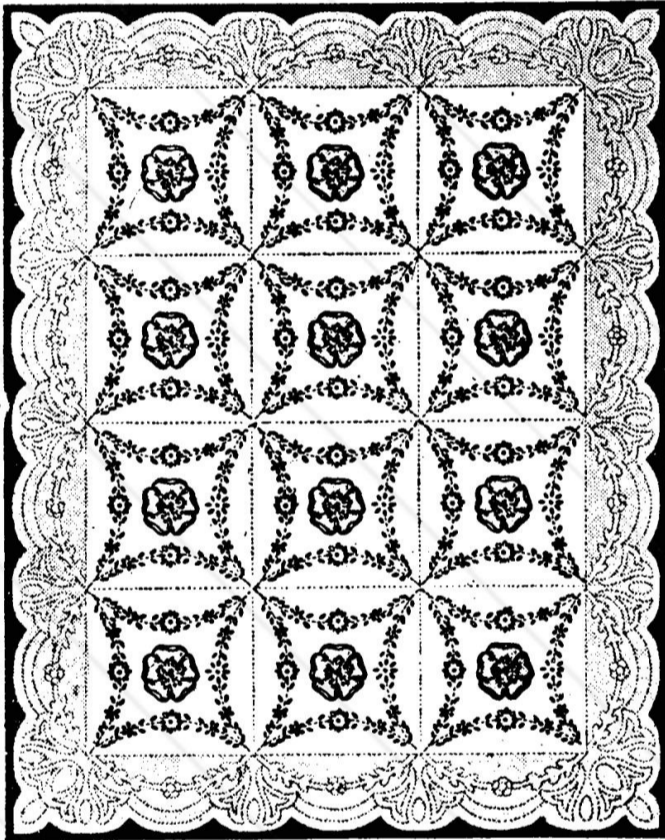

18-inch Blocks

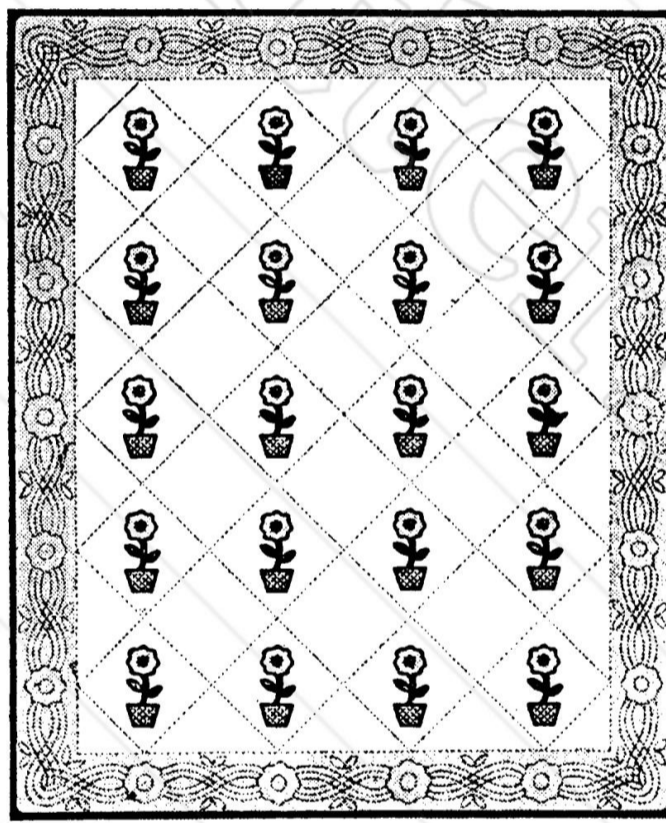

12-inch Blocks

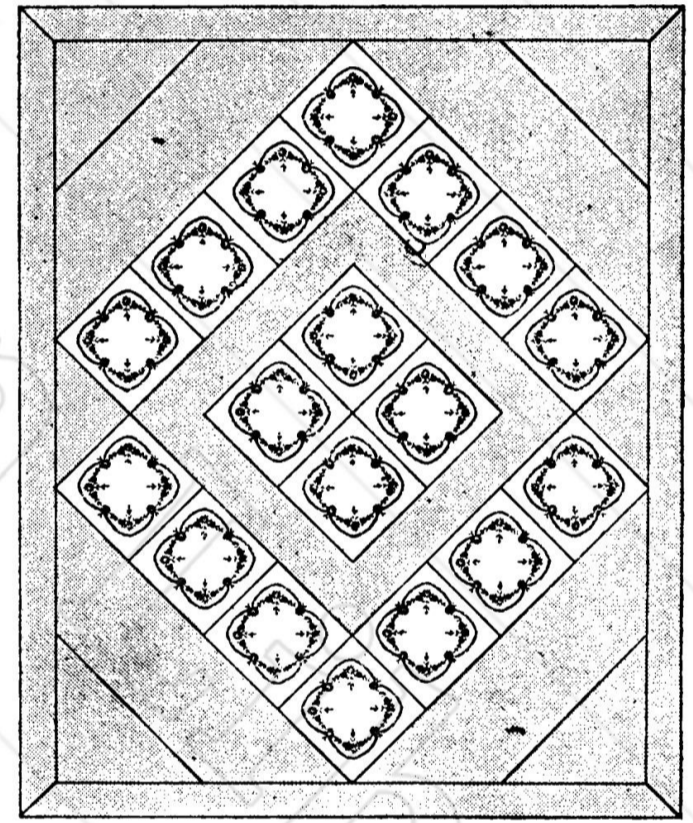

12-inch Blocks

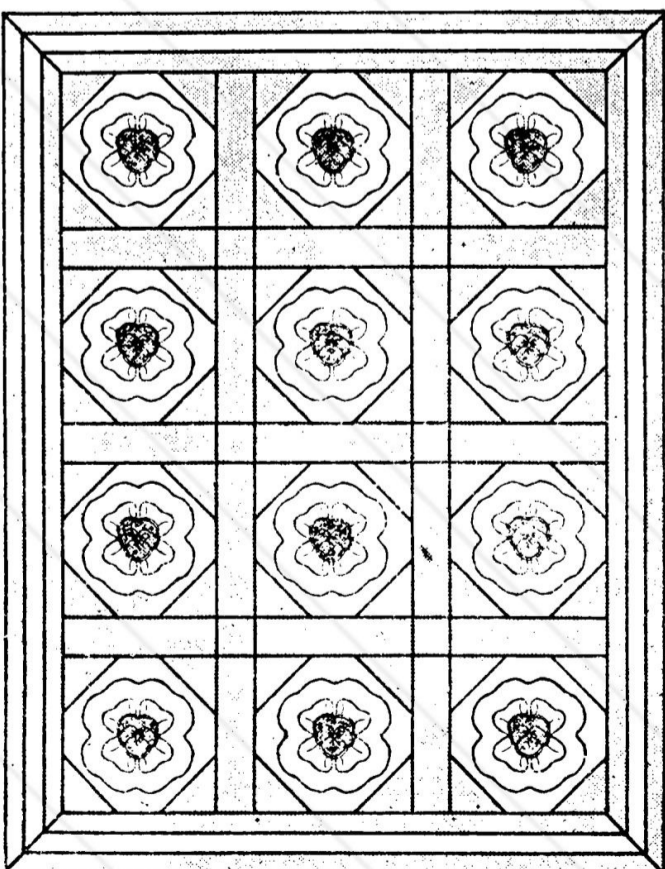

18-inch Blocks

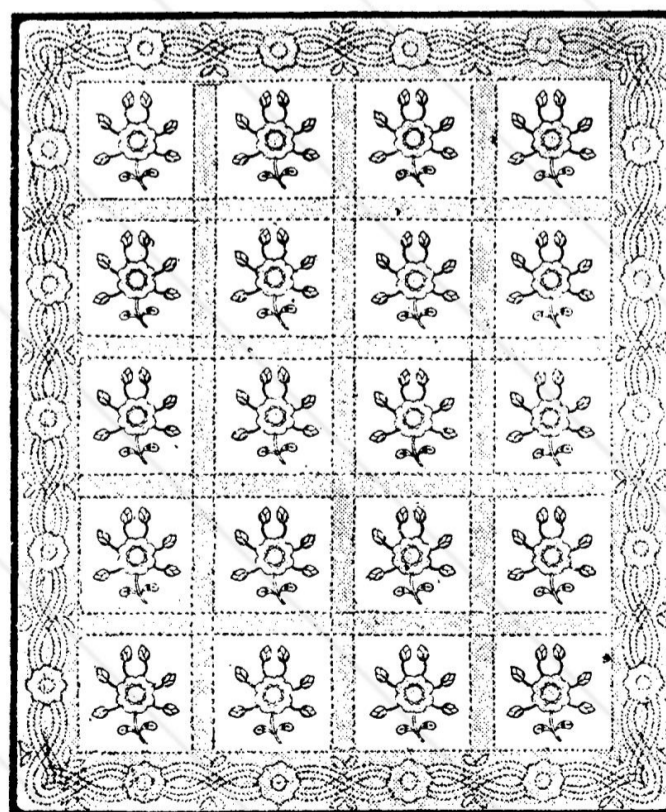

12-inch Blocks

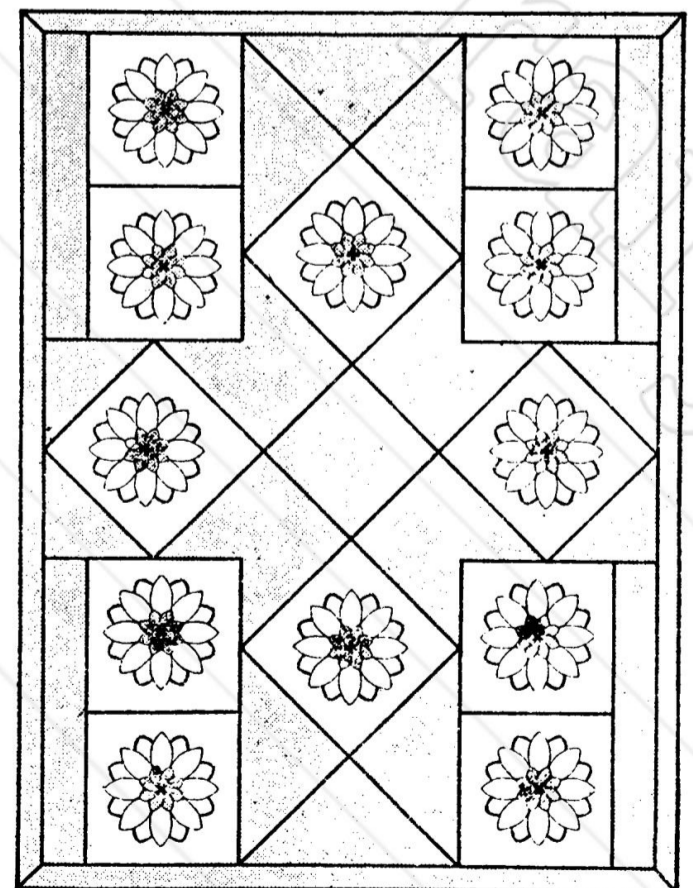

18-inch Blocks

Antique Pattern Library