



VARIED OCCUPATIONS IN WEAVING

Antique Pattern Library



VARIED OCCUPATIONS

IN

WEAVING

BY

LOUISA WALKER

HEAD MISTRESS OF FLEET ROAD BOARD SCHOOL, HAMPSTEAD
(INFANTS' DEPARTMENT)

MACMILLAN AND CO.

BEDFORD STREET, STRAND, LONDON

AND NEW YORK

1895

All rights reserved

Antique Pattern Library

THIS BOOK
IS RESPECTFULLY DEDICATED
(BY KIND PERMISSION)
TO THE
HON. EDWARD LYULPH STANLEY,
MEMBER OF THE LONDON SCHOOL BOARD
AND
MANAGER OF THE FLEET ROAD BOARD SCHOOLS,
HAMPSTEAD.

At whose suggestion the work has been compiled, and whose kind interest in, and appreciation of, the Author's varied occupations have been a source of much encouragement to her for many years.

Antique Pattern Library

PREFACE

THE present time being an age of "Varied Occupations," or, to speak more correctly, a time for introducing suitable occupations and usefulness into our schools, this book is written in the hope that it may be of service to teachers about to choose suitable occupations. The work described has been systematically taught in my own school for the past twenty years.

From the time that I received the first elements of Froëbelian principles at the Home and Colonial Training College until the present, it has been my aim to use the Froëbel gifts as the basis of all teaching, and when possible to apply the same excellent methods to other work of every-day usefulness.

Froëbel inculcated the broad and grand principles of the education and development of a child's faculties in the treatment of his gifts, but he never intended that the work should stop there ; he left it for future generations to further develop and perfect his plans.

Kindergarten teaching as it often is taught is too mechanical and narrow in its treatment, and allows little scope for inventive minds.

viii *VARIED OCCUPATIONS IN WEAVING*

Many of the articles illustrated in this book may not be constructed on an orthodox plan, but the ways and means employed have been adapted to meet the exigencies of each case and simplify matters for little workers.

The illustrations are from actual work produced in the school. The entire weaving was done by infants of five to seven years of age, and the material was afterwards manipulated into the useful articles by the teachers.

In schools for older children the entire work could be accomplished by the children themselves.

System and method are two essentials for gaining good results in varied occupations. The materials must be properly prepared and the teacher be well acquainted with her subject, so as to be capable of helping her pupils in their difficulties and of advising how to overcome them.

Pupil-teachers, candidates, and apt pupils might well be employed at the preparation at a stated time each week, and the training would be excellent for them hereafter.

As finished pieces are obtained from the children they should at once be applied to the making of something useful, to encourage the little ones on to more careful and skilful work. The pride and satisfaction of a little child's face at seeing its work so applied will amply repay any teacher for her trouble, and will also repay her monetarily, for these pretty articles are readily bought by the parents in remembrance of their children's cleverness.

I would advise all infant teachers to "make up" as they go along. The work then becomes easy, and the little things soon accumulate and can be proudly shown

PREFACE

ix

throughout the year. If left to the Examination the teacher becomes worried with other trifles and looks upon such work as a burden. I can only assure such an one that plenty of this kind of work makes the school attractive, and sharpens the children's intelligence as much as any other subject taught.

In this large school the classes are amalgamated for subjects such as Scripture, Tonic Sol-Fa, repetition, etc., when teachers in turn, with the help of a candidate, prepare their work, and it is to be hoped that, in the future, extra candidates will be allowed in schools for this preparation. The girls would be able to work in the class-room, listen to the teaching going on, and at the same time be "preparing" or "making up," much to their own benefit, and to the intense satisfaction of the children.

Antique Pattern Library

CONTENTS

	PAGE
MAT-PLAITING	1
EDUCATIONAL VALUE OF OCCUPATION	9
PATTERNS	13
UTILITY OF MATS	19
USEFUL APPLICATION OF THE MATS	33
OPEN WEAVING	37
DIAGONAL WEAVING	40
FREE WEAVING	44
FANCY WEAVING	50
PAPER-PLAITING	53
PAPER-FOLDING AND WEAVING	58
WEAVING IN RIBBON	63
STRING WEAVING	68
DIAGONAL WEAVING	77
FRAME WEAVING	83
STRING WEAVING ON CANE	102
WEAVING WITH MACRAMÉ TWINE	106
SINGLE STRAND CHAIR-CANING	111
DOUBLE STRAND CHAIR-CANING	118
CHAIR-CANING	121

VARIED OCCUPATIONS IN WEAVING

	PAGE
SPLIT STRAW WEAVING	126
STRAW WORK	159
STRAW PLAIT WEAVING	159
STRAW PLAIT WORK	162
CANE WEAVING	170
HORIZONTAL CANE WEAVING	172
BASKET WEAVING	174
FLAT CIRCULAR WEAVING	186
UPRIGHT CIRCULAR WEAVING	198
COMBINED CANE WEAVING	207

ILLUSTRATIONS

FIG.	PAGE
1. Mat I.	1
2. Mat I. showing Broad Strips raised	3
3. Mat I. woven with Broad and Narrow Strips	3
4. Mat I. „ „ Strips	3
5. Cotton Box made of Eight Mats (Mat I.)	4
6. Mat II. with Needle inserted	6
7. Blotting Book made of Four Mats (Mat II.)	7
8. Pin Tray made of Two Mats (Mat II.)	8
9. Mat III.	10
10. Steel Plaiting Needle	10
11. Closed Envelope	11
12. Open „	12
13. Weaving Patterns 1, 2, 3, Stage II.	14
14. „ 4, 5, 6	15
15. „ 7, 8	16
16. „ 9	17
17. Toilet Tidy	21
18. Flower Vase	22
19. Diagram of Flower Vase	22
20. Hexagonal Flower-pot Cover	23
21. Fourfold Fire-screen	24
22. Bellows Toilet Tidy	26
23, 24. Diagrams for Toilet Tidy	27
25. Stage III., Weaving Patterns 1, 2, 3	28
26. „ „ 4, 5	29

xiv		<i>VARIED OCCUPATIONS IN WEAVING</i>	
FIG.			PAGE
27.	Stage III., Weaving Patterns, 6, 7, 8	30
28.	„ „ 9, 10, 11	31
29.	„ „ 12, 13, 14	32
30.	Slipper Pocket	34
31.	Serviette Ring	34
32.	Card Basket	35
33.	Vase for Pampas-grass or Umbrellas	36
34.	Mat cut for Open Weaving	39
35.	Mat crossed „	40
36.	First Diagonal Woven Mat	41
37.	Finished Diagonal „	42
38.	Handkerchief Sachet in Diagonal Weaving	43
39.	Strips placed for Free Weaving	44
40.	Working Diagrams of Free Weaving	46
41, 42.	Letters made in Free Weaving, H, L, F, O, S	47
43.	Woven Piece for Hanging Bag	48
44.	Hanging Bag in Free Weaving	49
45.	Handkerchief Sachet in Free Weaving	50
46.	Open Papers in Fancy Weaving	51
47.	Fancy Weaving, Angles turned down	52
48.	„ „ interlaced	52
49.	„ Newspaper Rack	52
50.	Paper Plait of Three Strips	54
51.	Diagrams 1, 2, 3, 4, for Vandyke Plait	55
52.	{ Right side of Vandyke Plait	56
	{ Wrong „ „	56
53.	Newspaper Bag	57
54.	Paper Plaited Lamp Mat	58
55.	„ Toilet Tidy	61
56.	Diagram of Envelope Pocket	62
57.	Slate Pegged for Ribbon Weaving	63
58.	Ribbon Plaited Pin-cushion	64
59.	„ Handkerchief Sachet	65
60.	Folded Satin Sofa Cushion	67
61.	Slate Frame wound for String Weaving	70
62.	Plait of String	71

ILLUSTRATIONS		XV
FIG.		PAGE
63.	String Woven Toilet Tidy	71
64.	Buttonhole Looping on Ruler	72
65.	Round String Mat	73
66.	Fringe complete	73
67.	Weaving Frame	74
68.	String Handbag	76
69.	Diagonal String Weaving, Diagram 1	78
70.	" " " 2	79
71.	" " " 8	80
72.	" " " 4	81
73.	" " Doll's Bedstead	82
74.	Frame Weaving, "Star"	83
75.	" " "Sun"	84
76.	" " "Circular"	84
77.	" " "Belper"	85
78.	Sketch for Blackboard, Star Shape	85
79.	Windings of Sun Shape	86
80.	Star Picture Frame	87
81.	Glass fixed in position	88
82.	Brass-headed Nail	88
83.	Star Shape, Pattern 2, beginning	89
84.	" " 3, "	91
85.	" Card Basket	92
86.	" Key Rack	93
87.	" Pattern 4, beginning	94
88.	" " 5 "	96
89.	" " Picture Frame	97
90.	Sun Shape, Pattern 1	98
91.	Finished Plaque, Circular Shape	100
92.	Working Diagram of Plaque	101
93.	Foundation Diagram for Circular String Mat	103
94.	Border for Doll's Table	104
95.	Doll's Table in String	104
96.	Doll's Chair "	105
97.	Arrangement of Foundation for Macramé Twine Mat	107
98.	Pin-cushion	109

xvi	<i>VARIED OCCUPATIONS IN WEAVING</i>	PAGE
FIG.		
99.	Letter Rack of String Mats	110
100.	Slate drilled for Chair-caning	113
101.	Slate crossed in Single Strand Chair-caning	115
102.	Slate diagonally crossed in Single Strand Chair-caning	115
103.	Finished Slate in Single Strand Chair-caning	116
104.	Corner of Slate showing horizontal crossing of Double Strand Chair-caning	119
105.	Diagonal String Weaving (single)	120
106.	„ „ (double)	120
107.	Chair Seat Caning—First Crossing	123
108.	„ „ Second „	124
109.	„ „ Diagonal „	125
110.	„ „ Beading	126
111.	Split Straw Clip	131
112.	„ Slipper Pocket	133
113.	Diagram of Slipper Pocket	134
114.	Split Straw Dinner Mat	135
115.	How to draw the Ellipse	136
116.	Split Straw Blotter	138
117.	„ Photo Frame	141
118.	Diagram of „	142
119.	Split Straw Circular Pocket	143
120.	Diagram of „	144
121.	Split Straw Boat Cotton Basket	145
122.	Diagram of „ „	146
123.	Split Straw Octagonal Needle-book	147
124.	Heart Pin-cushion	148
125.	Split Straw Toilet Tidy	149
126.	Diagram of „	150
127.	Split Straw Hand-screen	151
128.	Patterns of Fans	152
129.	Split Straw Flower	153
130.	Diagram of Petal, No. 1	154
131.	„ „ No. 2	154
132.	„ „ No. 3	155
133.	Petals mounted, No. 4	155

ILLUSTRATIONS

xvii

FIG.	PAGE
134. Simple Flowers	156
135. Fancy Table and Stands	157
136. Straw Plait Hand Basket	161
137. „ Wall Pocket	164
138. „ Handbag	166
139. Foundation of Handbag	167
140. Glove Box (Straw Plait)	169
141. First Winding of Handkerchief Box	169
142. Second „ „	170
143. Cane Double Fern Pocket	175
144. Foundation of Four Strands	179
145. „ Eight „ No. 1	179
146. „ „ „ No. 2	180
147. „ „ „ No. 3	181
148. „ „ „ No. 4	181
149. Cane Border, No. 1	182
150. „ No. 2	183
151. „ No. 3	183
152. „ No. 4	184
153. „ No. 5	184
154. „ No. 6	184
155. „ No. 7	185
156. Cane Small Circular Mat	186
157. Division of Strands	187
158. Large Round Mat	190
159. Centre of Large Round Mat	191
160. Oval Dinner Mat	192
161. Foundation of Dinner Mat	193
162. Centre of Dinner Mat	194
163. Shell Fire-screen	196
164. Foundation Centre for Shell	197
165. Small Wheelbarrow	201
166. Mail Cart	203
167. Seat of Mail Cart	204
168. Lady's Sailor-hat Work-basket	206
169. Cotton Basket	208

xviii *VARIED OCCUPATIONS IN WEAVING*

FIG.		PAGE
170.	Small Card-basket	211
171.	Doll's Sailor-hat Fern-stand	212
172.	Turned-up Doll's Hat	213
173.	Hamper or Tumbler Case	215
174.	Art Pot	216
175.	Oval Hand-basket	218
176.	Fern-stand for Table	220
177.	Fern Vase with Stand	222
178.	Hanging Vase for Flowers	223

MAT-PLAITING

STAGE I.

MAT-PLAITING consists of interlacing strips of paper in either the same or different colours. The introduction of coloured strips renders the occupation more effective and interesting, and greatly adds to the beauty of the work.

The occupation is interesting and instructive, and teaches chiefly colour, number, and the combination of numbers, and also the simple multiplication and division of the same in a pleasant way.

The hand and eye are both trained in accuracy, form, and design, and the occupation forms the basis for more advanced work in weaving.

The instruction may be graduated and divided into three stages.

Stage I. may be taken by the lower infants upon leaving the babies' room. Children at this early stage have to acquire new ideas and an enlarged vocabulary, therefore during the teaching of this stage it is essential to describe

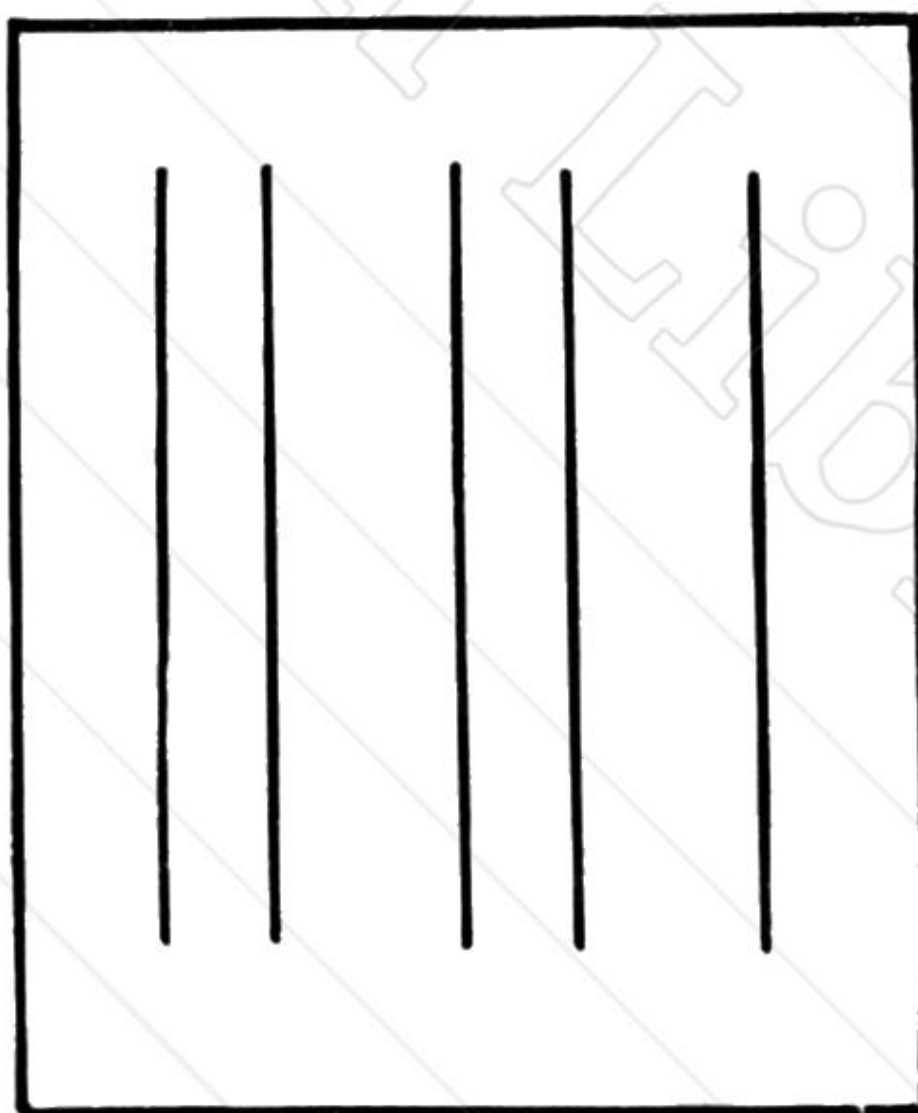

FIG. 1.

E

B

and speak of everything in correct terms. Stage I. consists of two mats, named Mats I. and II. They are stiff mats, nearly square, and are interlaced by corresponding strips of cardboard. Both mats and strips are sold in packets at all Kindergarten depôts. Mat I. consists of four strips, two broad and two narrow.

MAT NO. I.

Plan of Lesson.—Each child should be furnished with a blue mat, No. I., and four loose strips, two of which should be wide and two narrow. The mat is laid flat on the desk before the child, with the strips running vertically, and then examined. Count each corner, each side, and each strip. Look at the strips. Are they alike? How do they differ? The teacher might measure the width of the strips, and lead children to see they are not alike, and therefore must have different names. Give the new words “broad” and “narrow.” Lift up the two broad strips, lift up the two narrow. How many will two broad and two narrow strips make? What colour is the mat? Name other things of a blue colour, etc.

Children to compare the strips of the mat with those given them for weaving. Ask them to hold up one strip. Now hold up one from mat. They cannot. Lead them to see that the mat strips are fastened, and are held *tight* in the mat, and therefore are called *tight* strips. Those given for weaving can be taken up one by one, and are called *loose*. Exercise children in the new words, thus, touch a tight strip, touch a loose strip, lift up a broad tight strip, hold up a narrow loose strip, etc.

Weaving.—Children to take a broad loose strip in the

MAT-PLAITING

right hand. Upon the left hand raise the two broad tight strips.

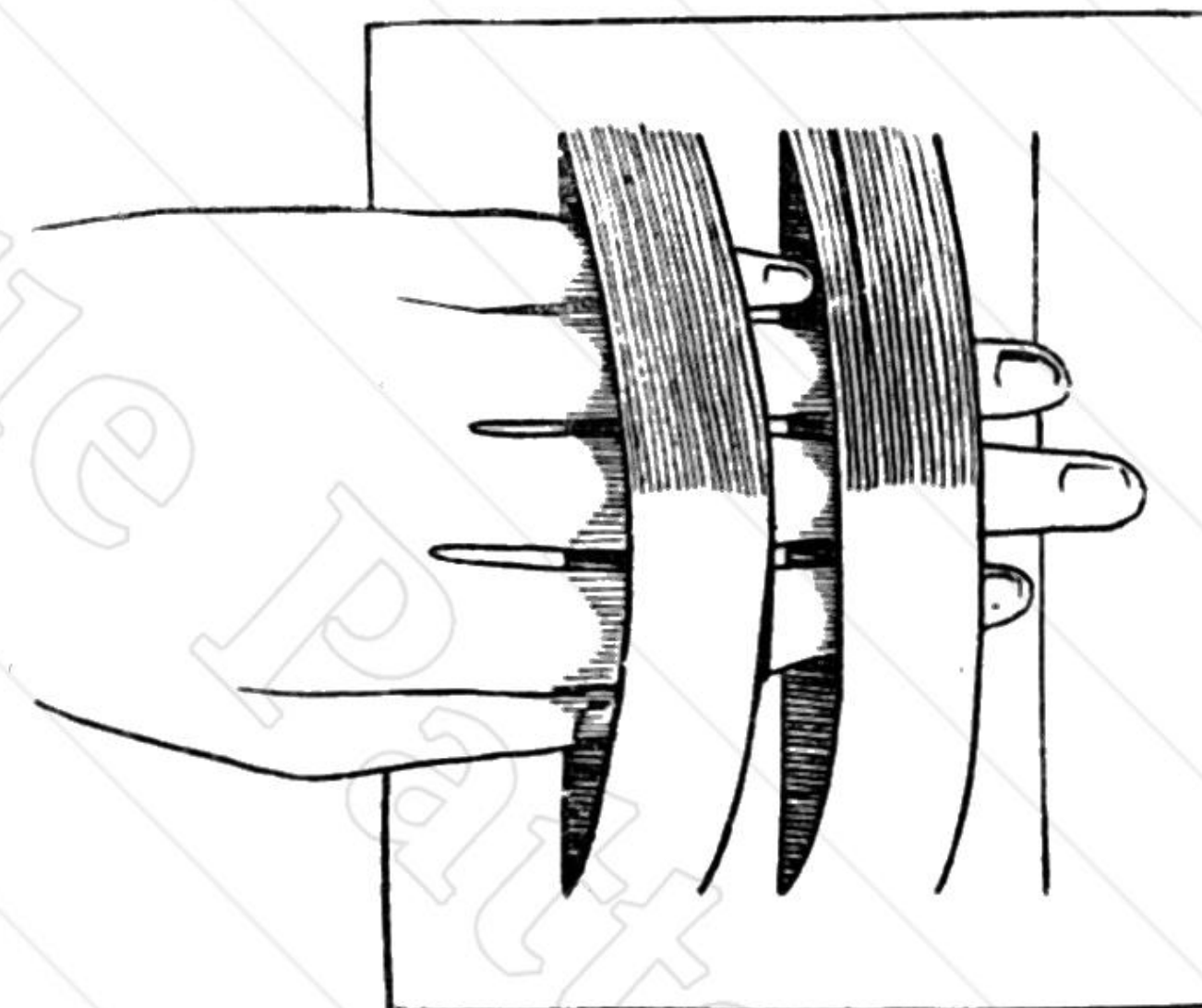

FIG. 2.

Compare these strips to wide arches, talk about bridges, tunnels, etc., and children to tell how we go through

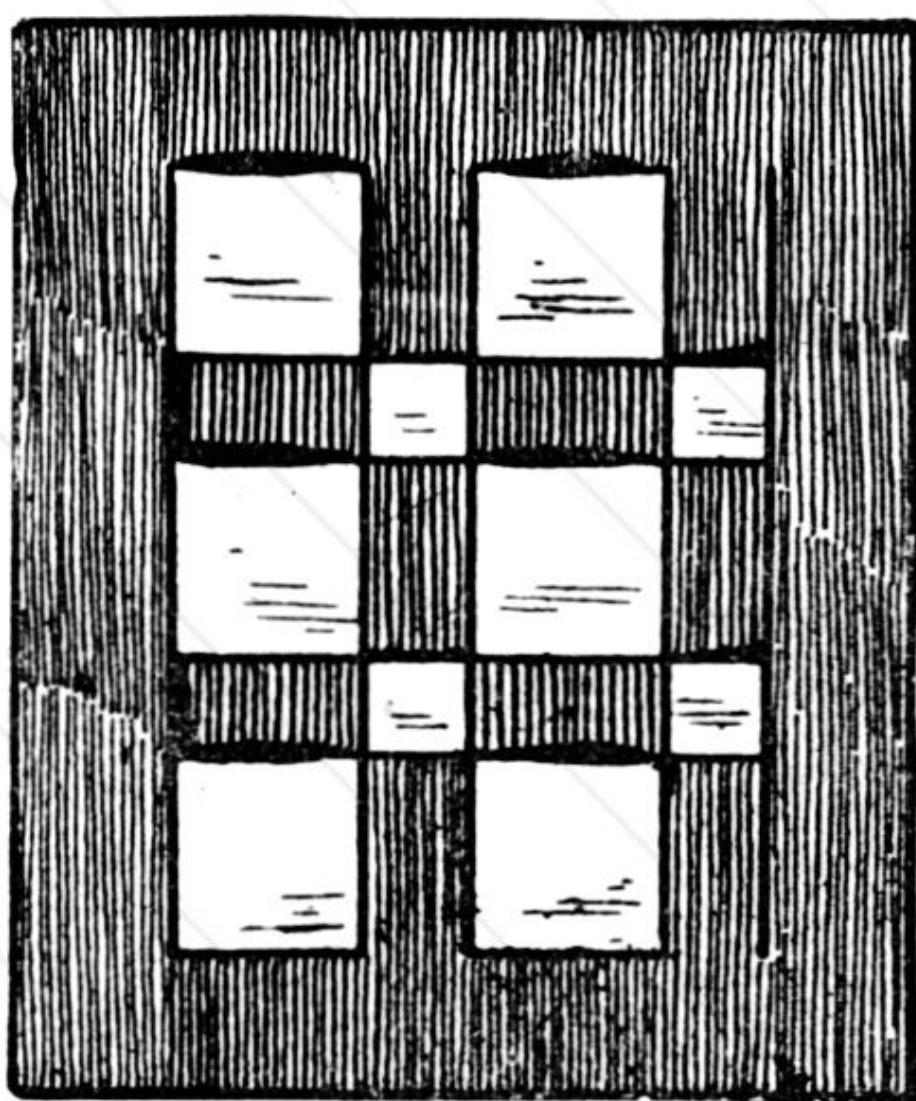

FIG. 3.—Mat woven with broad and narrow strips.

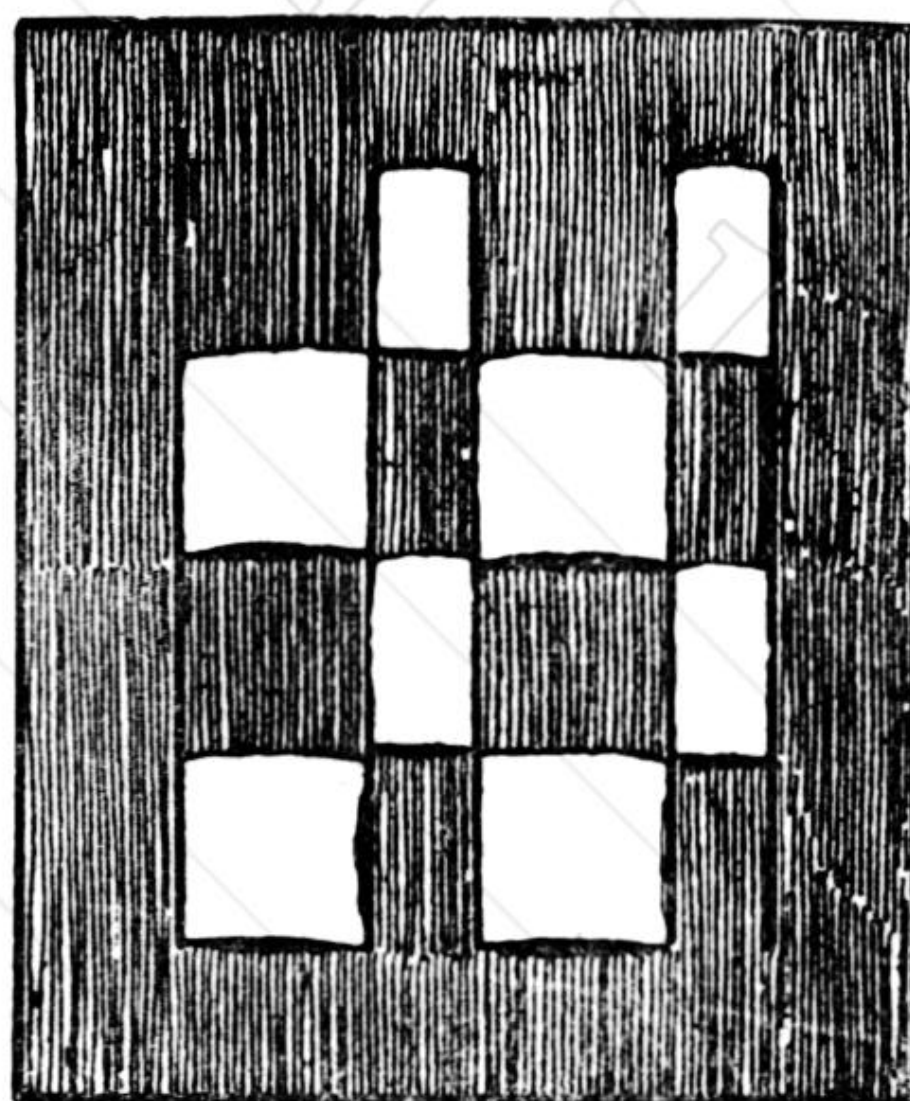

FIG. 4.—Mat woven with broad strips.

tunnels. The loose strip is to represent the train, and must be passed under the arches and the left hand with-

drawn. Next lift up the two narrow strips on left hand, and thread underneath a narrow loose strip. Two more strips done in the same way complete the mat. Keep the ends of the loose strips on the working side, which is the wrong side.

Cotton Box.—Eight of these mats make very useful cotton boxes. Cut all the ends even and about half an

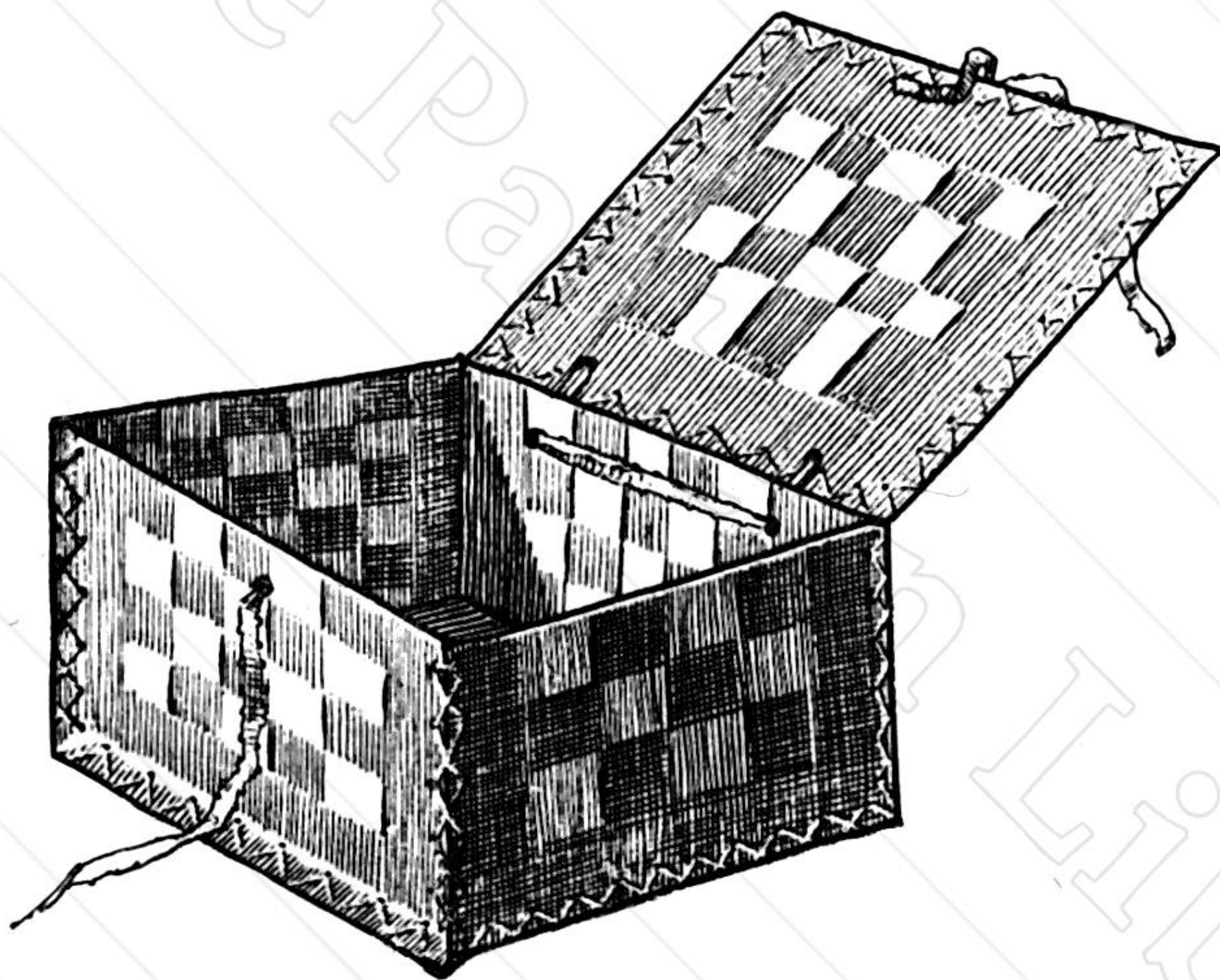

FIG. 5.

inch from the edge of mat. Paste two together (the ends inside) for the cover, and two for the bottom.

Take the other four and crease in half and paste, two the long way of mat and two the short. Do the pasting all at one time, and place under a weight to dry. The border of short sides will need a little cutting to fit with long sides. The older children can prick holes at the edges, and sew together, as in Fig. 5. The cover is sewn all round to match the lower edges, and then secured by passing a

MAT-PLAITING

5

ribbon through two punched holes in the box and cover, and tying in a smart bow on the top of box.

Two ends of ribbon attached to lid and front complete a very useful article.

MAT No. II.

Materials.—1. Thin cardboard mats consisting of six tight strips.

2. White or coloured loose cardboard strips of $\frac{1}{2}$ inch width.

Method.—Mat II. presents to the children a new difficulty, and therefore the first step will be to examine carefully the mat, to note the colour, shape, sides, corners, etc., and compare it with Mat I. The two mats are similar in every respect, except in the number and size of the strips. Mat I. has two broad and two narrow strips dealing with the number four, and Mat II. has six strips, all of the same width. The words “broad” and “narrow” cannot now be applied to the weaving, but the terms “up” and “down” are substituted instead. This is puzzling to young children at first, and therefore numerous exercises must be given of “lifting up” one strip, such as “Lift up No. 2 strip,” “Lift up No. 4,” and No. 6, and so on. When the children fully understand the idea of “lifting up” one strip, then the weaving can be commenced and alternated in the succeeding rows. This step is the foundation of all weaving, and when once thoroughly understood by the children the occupation may be varied by weaving in materials and cane and straw, etc.

No needles are used at this stage, the cardboard mat and strips being sufficiently firm to use without.

The teacher should prepare a similar mat on a larger

VARIED OCCUPATIONS IN WEAVING

scale, and fix to the blackboard. She must then "lift up" her strips with a lath, and weave *one strip up* and one strip *down* with the children.

Let the strips be counted and named as strips 1, 2, 3, 4, 5, 6. For first row "lift up" Nos. 1, 3, and 5. When the children have completed the first row, let them count the strips "lifted up" (3) and the strips put down (3). Compare the weaving to square windows—three white and three blue—making six in all. Simple arithmetical problems

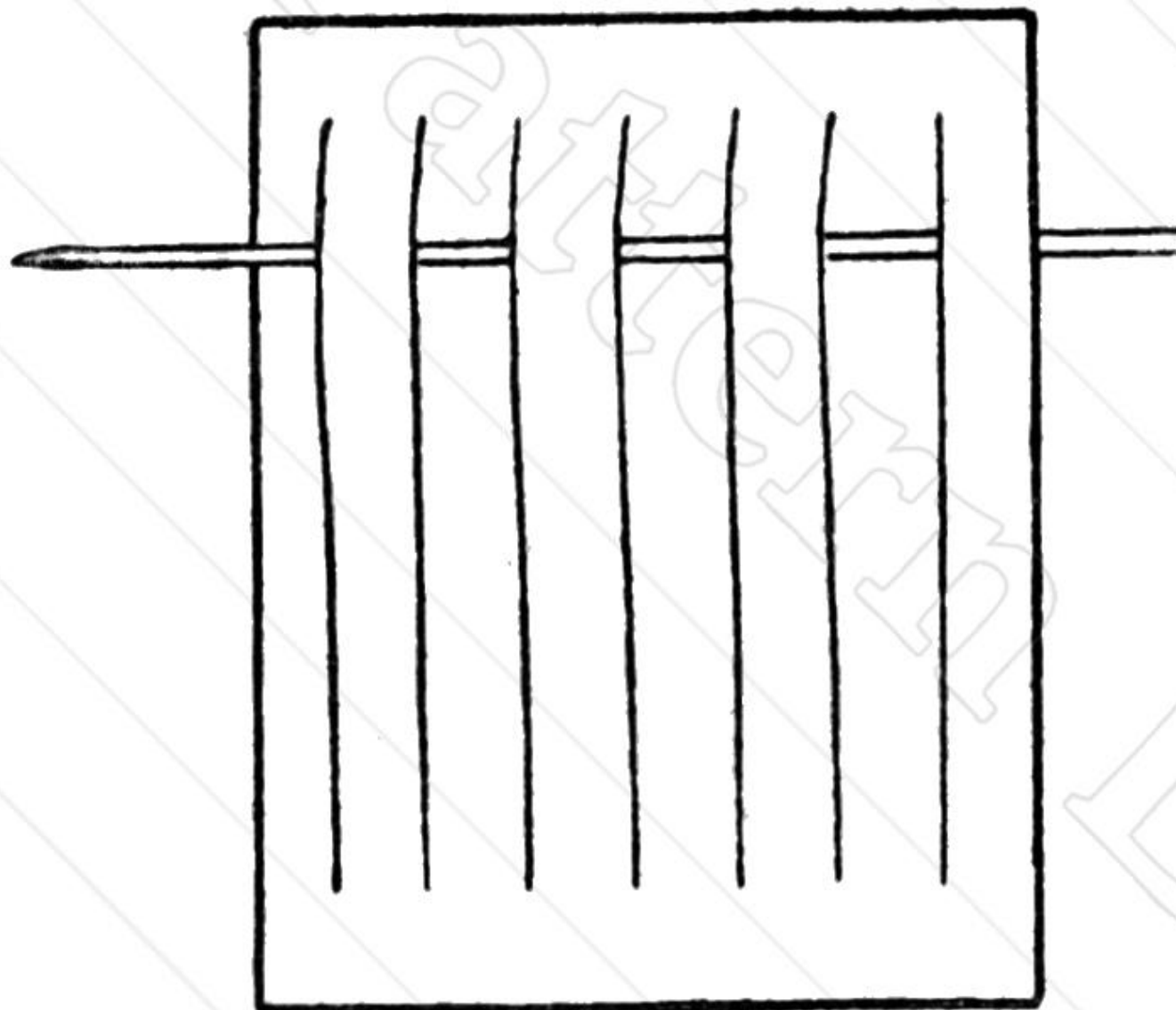

FIG. 6.

may now be asked, and as each succeeding row is woven, the questions put should increase in difficulty. The children will soon discern a mistake in the weaving, and correct their own inaccuracies.

The weaving of "one" is the only pattern taught in this mat, but variety may be obtained in using strips of different colours and of different widths.

This mat may be utilised as a great teaching aid to number, form, and colour in a pleasant way.

Each child's name should be lightly pencilled on his

MAT-PLAITING

7

mat, and when finished it will be a source of pleasure to take home as a specimen of his own work.

A few of the best mats might be made into useful articles with very little trouble.

Blotting Book.—Take four finished mats. Cut the loose strips even, about half an inch from the edge. With preserved paste or starch, evenly spread over one mat,

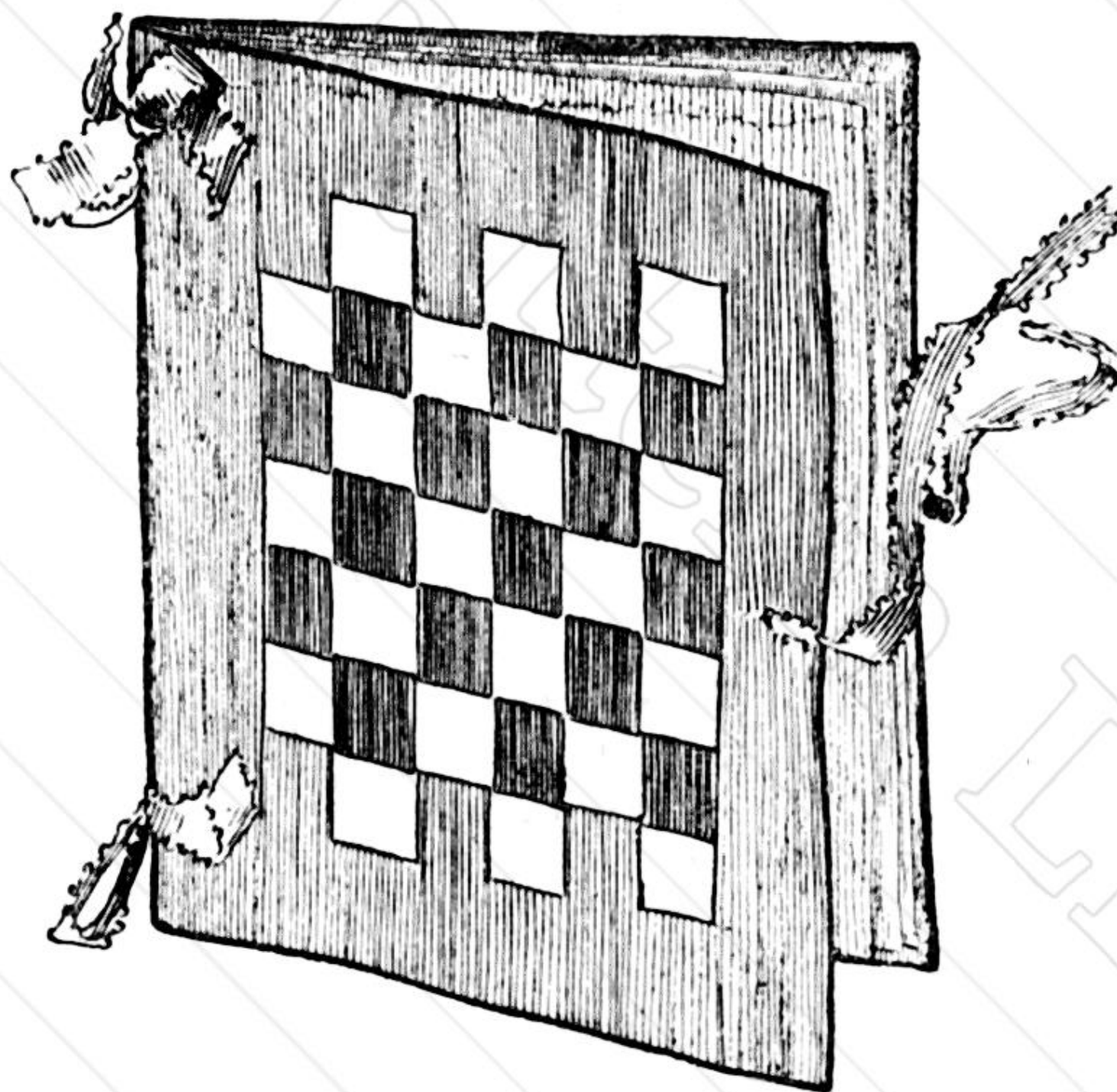

FIG. 7.—Blotting Book.

stick each two exactly together, placing the loose strips inside. A weight must be placed on the top, and the mats left to dry until perfectly smooth and flat. The children in the sewing class can improve the border by pricking holes and working over the edges with a cross or button-hole stitch.

Two holes are next punched in the border of mats, and three sheets of pink or white blotting-paper are inserted

and a ribbon threaded through the whole, and tied in two bows at the back.

These books are readily sold for a few pence to cover cost of ribbon and blotting-paper.

A Needle-book may be made of two mats pasted together in the same manner, and then folded in half whilst the paste is damp and placed under a weight.

Ornament the edges with a cross or button-hole stitch, and sew inside three pieces of red flannel not quite the size of the mat. Snip the edges of the flannel and fasten on short ribbons to tie the covers together in front, and also

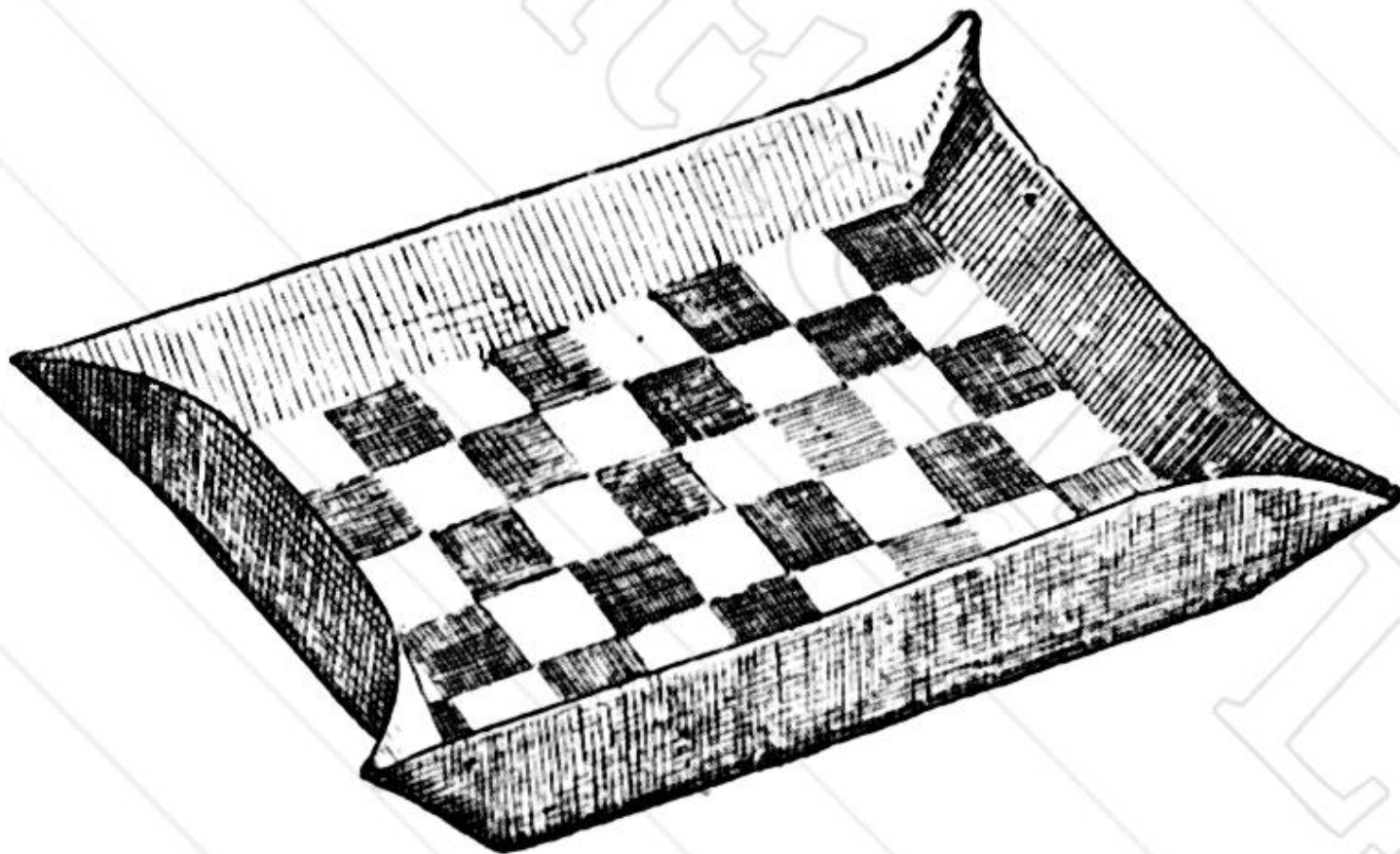

FIG. 8.—Pin Tray.

pass a ribbon inside the flannel strips, and tie on the outside at the back.

Pin Tray.—Take two mats and paste together as before described. Let the mats remain under a weight for two minutes, until the paste has adhered and the mats are damp and pliable. Press up the border all round, and pinch the corners outwards, holding them in position for a few moments. A string tied across the length and width will hold the border in position till the tray is dry.

Square Flower-pot Cover.—Eight mats pasted together will make a very good flower-pot cover. The shape may be

EDUCATIONAL VALUE OF OCCUPATION 9

square, using the mats as they are, or each mat could be narrowed by cutting the border at the base. Fasten the mats together with brass-headed paper fasteners. If a circular shape is needed, the mats must be tied in this form when damp, as they cannot be made circular after, when dry. To do this, paste the mats together and tie them round a bottle or any round object until dry. Cut the border from top corner and narrow it towards the bottom. Fasten the mats together with the brass knob paper fasteners. These fasteners are quite an ornamentation, and make a very neat and compact way of fastening. Toilet tidies, letter racks, card baskets, and other articles are easily made in the same way.

EDUCATIONAL VALUE OF OCCUPATION

STAGE II.

(a) It may be utilised to teach the addition and multiplication of numbers.

(b) It is good for the cultivation of the imitative and inventive faculties, and affords scope for practical ingenuity in designing new patterns.

(c) It teaches regularity and symmetry, thus training both hand and eye to correctness.

(d) It forms an educational yet pleasant and interesting occupation for children.

(e) It teaches colour, and cultivates a taste for combining the same.

Materials required for each Child.—1. A brown paper envelope to contain materials.

2. A stiff cardboard mat, No. III., and thin corresponding mat, No. IV.

3. Cardboard and paper strips $\frac{1}{4}$ inch in width.
4. Steel plaiting needle.

Method employed.—The mats used in Stage I. were stiff, and woven with stiff strips without needles. The number “one” formed the basis of that stage, and the

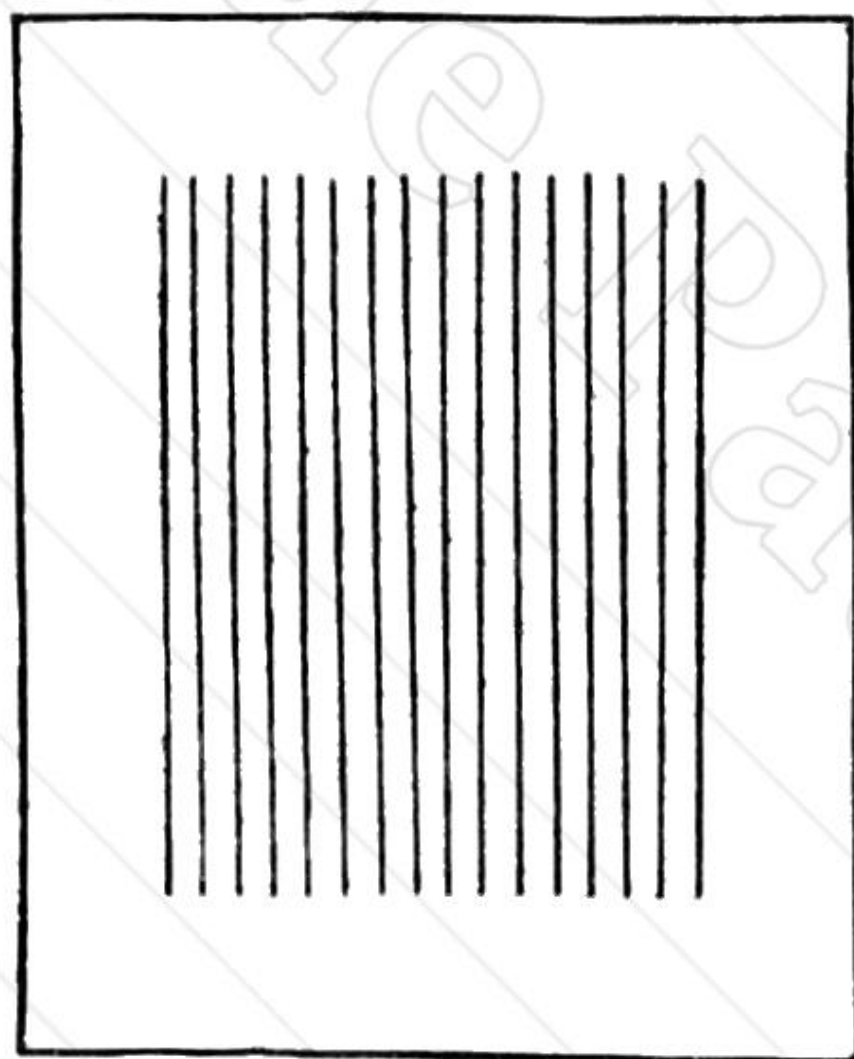

FIG. 9.—Mat III.

children were taught the simple rule of reversing the weaving every alternate row.

Stage II. introduces a mat of greater difficulty, and involves the use of a plaiting needle.

The Mat.—Mat III. is an oblong cardboard mat, consisting of fifteen tight strips, and is termed the teaching or class mat, because it is used chiefly for preliminary practice in teach-

ing a pattern, which is afterwards reproduced by the child upon the corresponding thin Mat IV.

The Needle.—Steel needles with a new spring action are the best. The globular end is pressed and the clips open, ready to receive the weaving strip. Each child should



FIG. 10.—Steel Plaiting Needle.

practise threading the needle. It might form a preliminary exercise to the weaving and a short drill be arranged for the exercise—*e.g.*

Drill.—(1) Take needles in left hand and hold the spring horizontally between finger and thumb.

(2) Take strip in right hand.

- (3) Press open the spring of needle.
- (4) Insert strip in the clip.
- (5) Show needle threaded.

Children must be taught that the use of the needle is to "lift up," and various exercises of "lifting up" "one" and "two" strips should be given with the unthreaded needle before actual weaving is commenced.

When the children are proficient in this exercise, and thoroughly understand the term of "lifting up," then a pattern may be commenced.

Each child should be provided with a brown paper envelope containing two mats (III. and IV.) and a plaiting needle. The child's name should be legibly written on the outside, so as to ensure each child having its own work, and also to aid in quickness of distribution.

Demonstration.—The teacher will require a weaving demonstration frame, or she must prepare a duplicate mat on a large scale for teaching purposes. The frame consists of a wooden border, with strips of green braid, and the weaving is done with wooden laths.

A chequered board and coloured chalks are necessary to illustrate the weaving on black-board. Method and order are essentials in good schools, and therefore before the children begin the intricacies of mat weaving, it is desirable to train them in the management of their materials, thus :—



FIG. 11.—Closed Envelope.

- Mat Drill.*—1. Place envelopes on desk, flap at top.
 2. Open and turn back top flap.
 3. Open and turn outwards side flaps.
 4. Open and turn back lower flaps.

5. Take out mats and needle.
6. Shut envelopes and place aside.

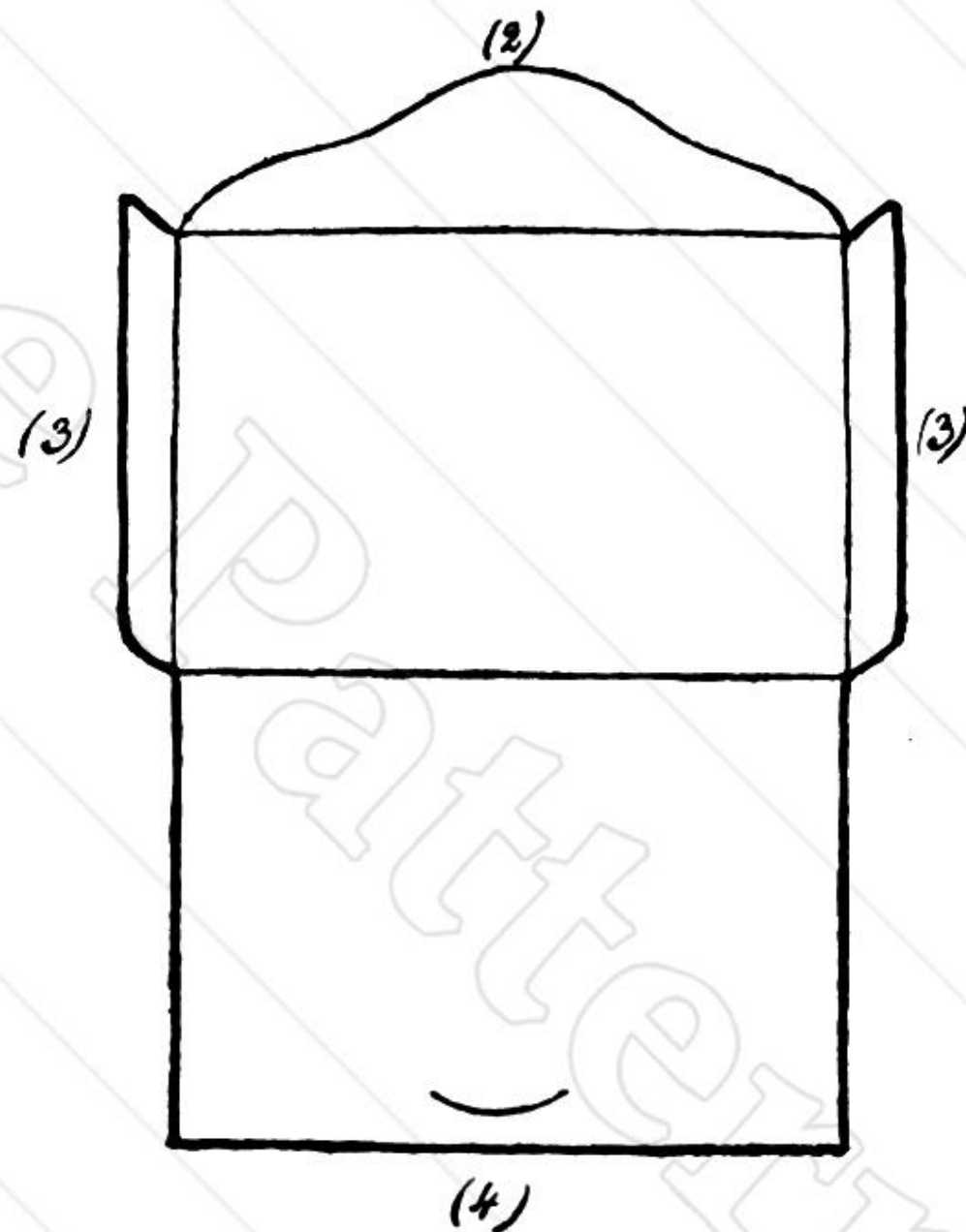

FIG. 12.—Open Envelope.

Plan of Lesson.—I. *Examination of Mat.*—Refer to the border as the frame, and let children name other articles with frames, *e.g.* slates, pictures, looking-glass, etc. Tight strips to be counted (fifteen). How many times can five be counted? How many times three? etc.

II. *Threading the Needle.*—The children first learn to thread their needles. This is a simple exercise, and will easily be accomplished.

III. *The Weaving.*—For a first lesson, the cardboard mat No. III. only should be used, but afterwards, in subsequent patterns, it is best to make this the teaching mat, and have the whole class weave row by row with the teacher, for at least six rows, after which all the proficient children should be allowed to reproduce the same pattern upon the private mat No. IV., which corresponds in size and

PATTERNS

13

strips to Mat III., the only difference being in the thickness.

The teacher is thus enabled to devote her attention to the backward ones, and keep the whole class at the same stage upon the teaching mat.

Three or four different patterns may be taught upon Mat III., and Mat IV. will be a further exercise for producing the entire pattern of each.

As the weaving proceeds, the pattern should be illustrated in coloured chalks upon the Kindergarten board, and if the copy be retained, it will form a good exercise for a lesson in Kindergarten, drawing, and shading.

The weaving is easier to understand when done on the wrong side of the mat. By so doing, the right side of the mat is placed downwards on the desk, and thus kept clean, and the ends of the strips being kept on the upper side, the children have to deal only with the strips, and are not puzzled about the frame or border.

PATTERNS

Materials.—Brown paper envelope, containing needle and Mats III. and IV. and loose strips.

Mat Drill.—Open envelopes with drill and practise the new pattern with unthreaded needles. This course consists of patterns based on the numbers “one” and “two,” and the combination and transference right and left of the same. Opportunity should be taken of teaching arithmetic with these numbers.

As the alternate rows are not always similar, the attention must be concentrated upon the work, and an inspection should be made quickly of the rows as they are woven.

The following illustrations are good patterns for this course, and give an idea how Mat III. should be used for teaching the different patterns. Each pattern illustrates the representation which should appear on the chequered blackboard.

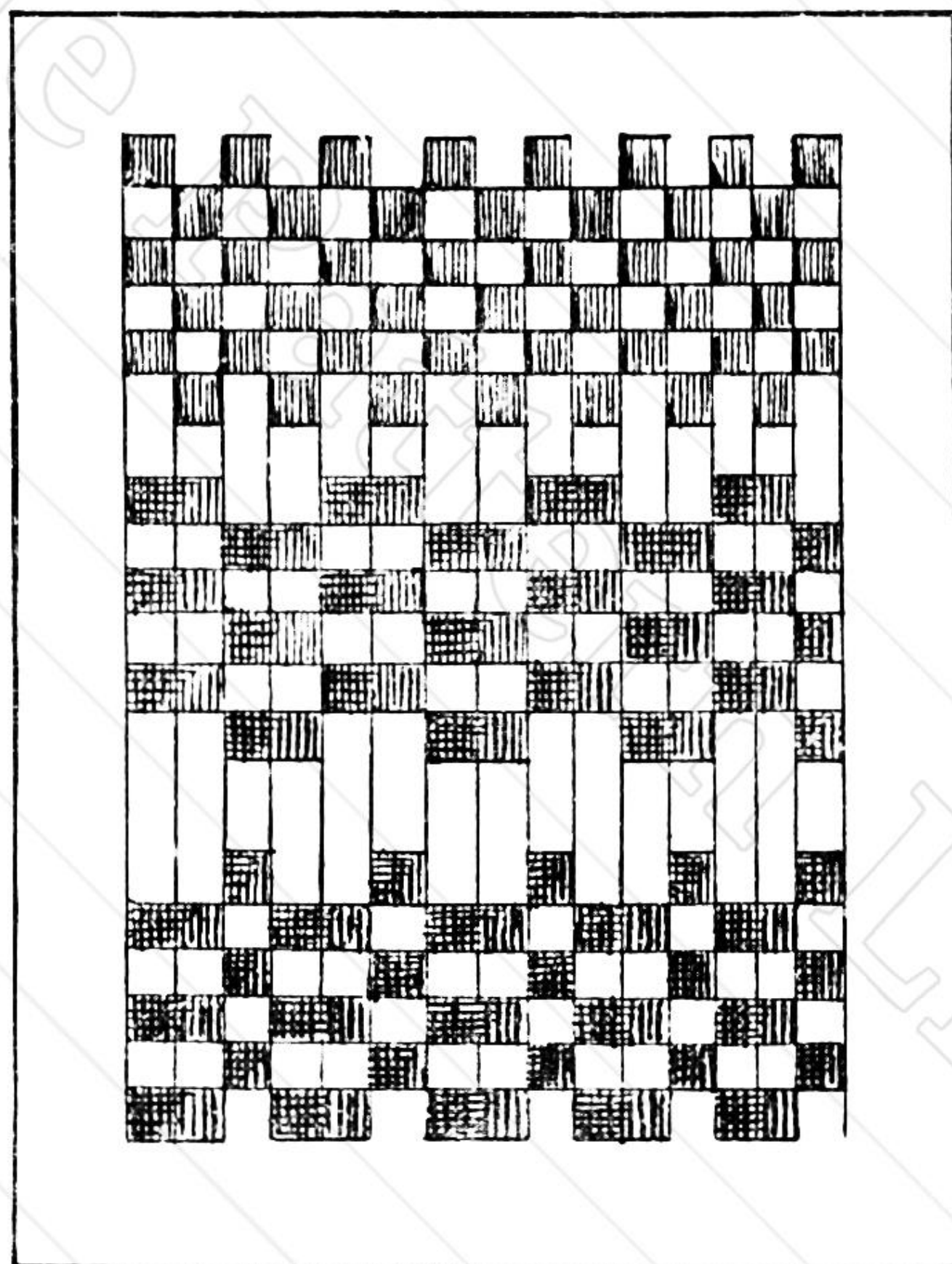

FIG. 13.—Patterns 1, 2, 3.

PATTERNS 1, 2, 3

No. 1

First Row.—1 down, 1 up. } The second row is the reverse
Second Row.—1 up, 1 down. } of the first.

PATTERNS

No. 2

First Row.—2 up, 2 down. } The second row is the reverse
Second Row.—2 down, 2 up. } of the first.

No. 3

First Row.—1 down, 2 up. } Combination of 1 and 2.
Second Row.—1 up, 2 down. } Second line reverse of first.

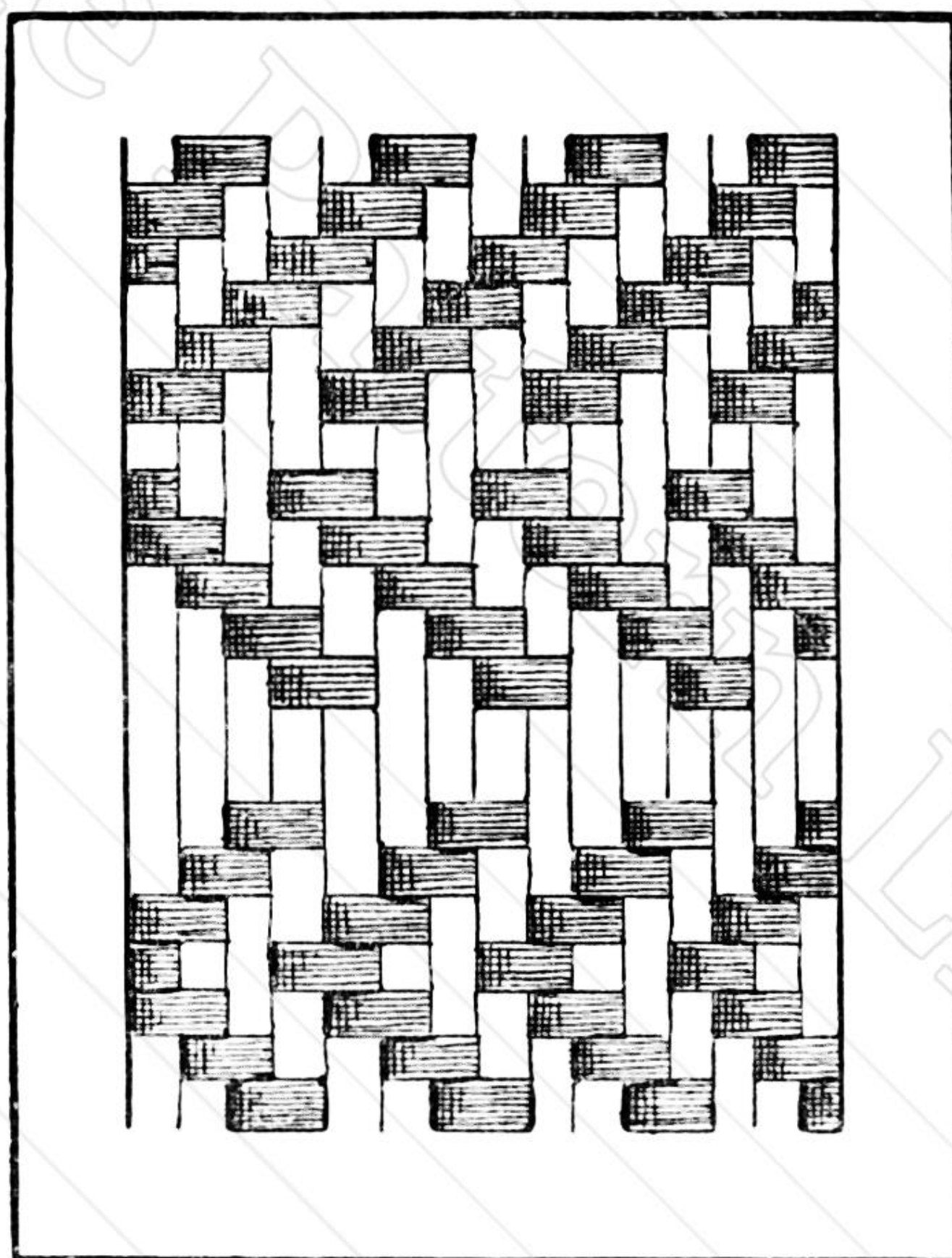

FIG. 14.—Patterns 4, 5, 6.

PATTERNS 4, 5, 6

No. 4

First Row.—2 down, 2 up. } Step pattern to left.
Second Row.—1 up, 2 down, 2 up. } Transfer pattern
Third Row.—2 up, 2 down, 2 up. } one strip to left for
Fourth Row.—1 down, 2 up, 2 down. } four rows. Repeat.

No. 5

First Row.—2 up, 2 down.

Second Row.—1 up, 2 down, 2 up.

Third Row.—2 down, 2 up.

Fourth Row.—1 down, 2 up, 2 down.

} Step pattern to right.

No. 6

Patterns 4 and 5 combined. Step patterns to right and left.

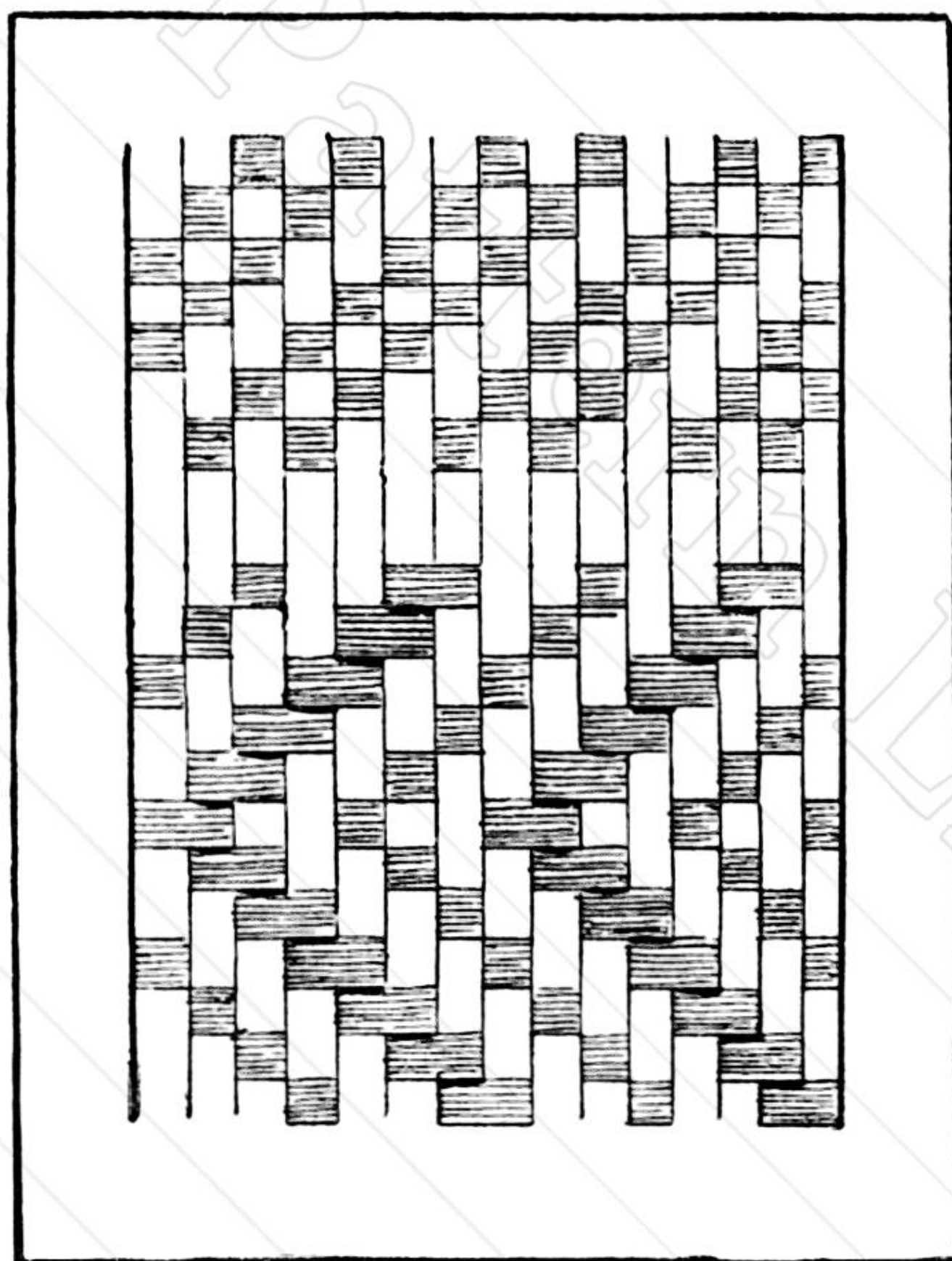

FIG. 15.—Patterns 7 and 8.

PATTERNS 7 and 8

No. 7

First Row.—1 down, 1 up, 1 down, 2 up. Repeat three times.

PATTERNS

Second Row.—1 up, 1 down, 1 up, 1 down, 2 up, etc.
Repeat three times.

Third Row.—2 up, 1 down, 1 up, 1 down, 2 up, etc.

No. 8

First Row.—1 up, 2 down, 2 up, 1 down, 2 up, 2 down,
2 up, 1 down, 2 up.

Second Row.—2 up, 2 down, 2 up, 1 down, 2 up, 2 down,
2 up, 1 down, 1 up.

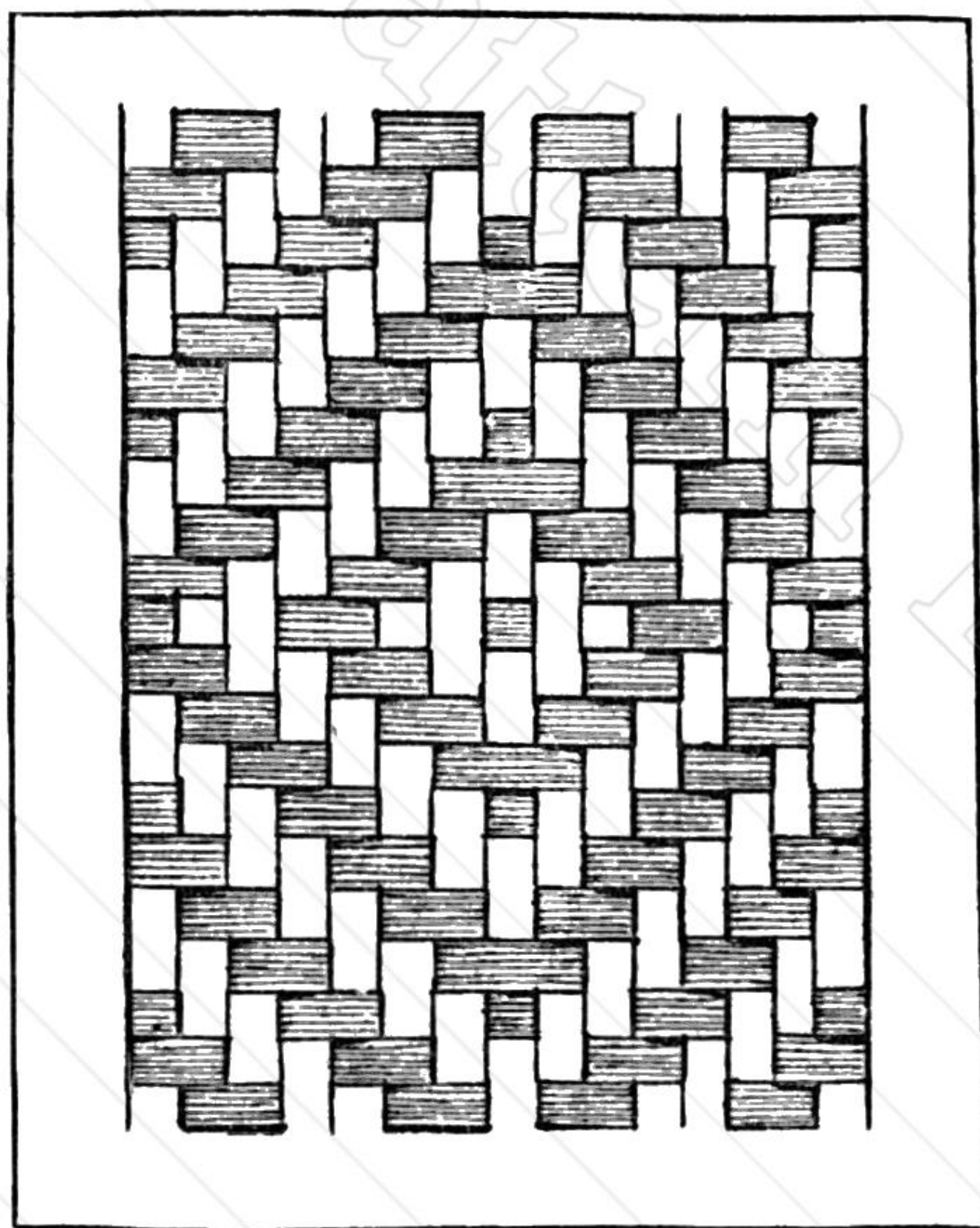

FIG. 16.—Pattern 9.

Third Row.—1 down, 2 up, 2 down, 2 up, 1 down, 2 up,
2 down, 2 up, 1 down. Repeat for three more rows, and
reverse for next six rows.

C

The difficulty of these step patterns is only at the beginning of each row, after which the weaving is the same.

The work is much beautified and improved by weaving the rows of a pattern in different colours. The little weavers might be allowed to choose their own mats and strips. After working this series of patterns the children will have gained considerable skill and proficiency in the work, and the lesson might with advantage be varied, and a pattern given out from dictation, or be written in words upon the blackboard. Mat IX. forms a good exercise for employing either method.

PATTERN 9

Mat IX. must be commenced in the centre, and a corresponding strip woven top and bottom of the centre each time.

Dictation.—Fold mat in half and weave first strip across centre.

1. 1 down, 2 up, 2 down, 2 up, 1 down, 2 up, 2 down, 2 up, 1 down.

2. Top of 1. { 2 down, 2 up, 2 down, 3 up, 2 down,
2 up, 2 down.

2. Under 1. { 2 down, 2 up, 2 down, 3 up, 2 down,
2 up, 2 down.

3. Top of 2. { 1 up, 2 down, 2 up, 2 down, 1 up, 2 down,
3. Under 3. } 2 up, 2 down, 1 up.

4. } 2 up, 2 down, 2 up, 3 down, 2 up, 2 down, 2 up,
4. } 2 down.

5. Same as No. 1.

5. Same as No. 1. Repeat from lines 2.

Lamp Mat.—This pattern when finished makes a good

UTILITY OF MATS

19

centre for a lamp mat. The mat should be pasted on the centre of a square of cardboard, leaving a 2-inch margin all round. The margin is covered with strips of fringed tissue paper, cut and curled about 2 inches deep.

UTILITY OF MATS

Amongst the numerous varieties of Kindergarten occupations, all taxing to the utmost the skill and ingenuity of the teacher, it is pleasing to find an occupation which is not only educationally beneficial, but may, when completed, be put to use.

Some teachers object to utilise the children's Kindergarten work, and consider it the proper thing to show the mats just as they leave the children's hands.

This is hardly a correct principle to follow, because little children require stimulation in their work, and when they have completed all that can be expected of them, then it is for the teacher to further stimulate and show how useful their work can be made. It is most discouraging to children to depreciate their poorest work, for such work might with advantage be given away after each lesson, and the children be encouraged to pull out the strips and weave a pattern at home, which they could bring at the time of the next lesson.

Towards the end of the school year a large number of good mats will necessarily be produced from an ordinary class, and many of these can be easily turned to a useful purpose without interfering with the weaving. These useful little articles are very pretty and attractive when made in soft harmonious colours, and have a ready sale.

As each mat is finished the loose ends should be cut even

and gummed to the border, and then placed in a thick book, where it will be kept pressed and clean until wanted. The process of mounting and making up should be undertaken when a teacher can afford to spend two or three hours at the work at one time. She should prepare beforehand a basin of boiled starch or paste made in the following way:—Take two tablespoonfuls of flour (rye flour is best) and mix with cold water *thoroughly* by stirring until the paste has a thin creamy consistence, and then boil, when it will thicken. If found too thick in cooling, add boiling water till the desired degree of thickness be obtained. Use a soft brush, and put on as little paste as possible.

Paste very evenly, and upon a large surface, rub the paste with the flat open hand. The *hand* will wash, and this process smooths out the lumps better than any other. Do *not* paste the *mats*, but the material upon which they are to be mounted. Place the mats in position and press smooth with a sheet of clean blotting-paper and soft cloth, and leave to dry. If required to form a round object the mats must be tied whilst damp to a bottle or tin to dry in that position. Several of the most proficient workers might do all the pasting under the superintendence of the teacher.

TOILET TIDY

Five mats are required for this triple toilet tidy.

Two mats are mounted on a piece of tinted cardboard for the foundation.

Three others are twisted into scoops, and fastened together with brass-headed paper fasteners, and fixed with the same to the foundation card.

The corners and centre are finished with cut rosettes

UTILITY OF MATS

21

of crinkled paper, and the whole suspended with a bow of ribbon.

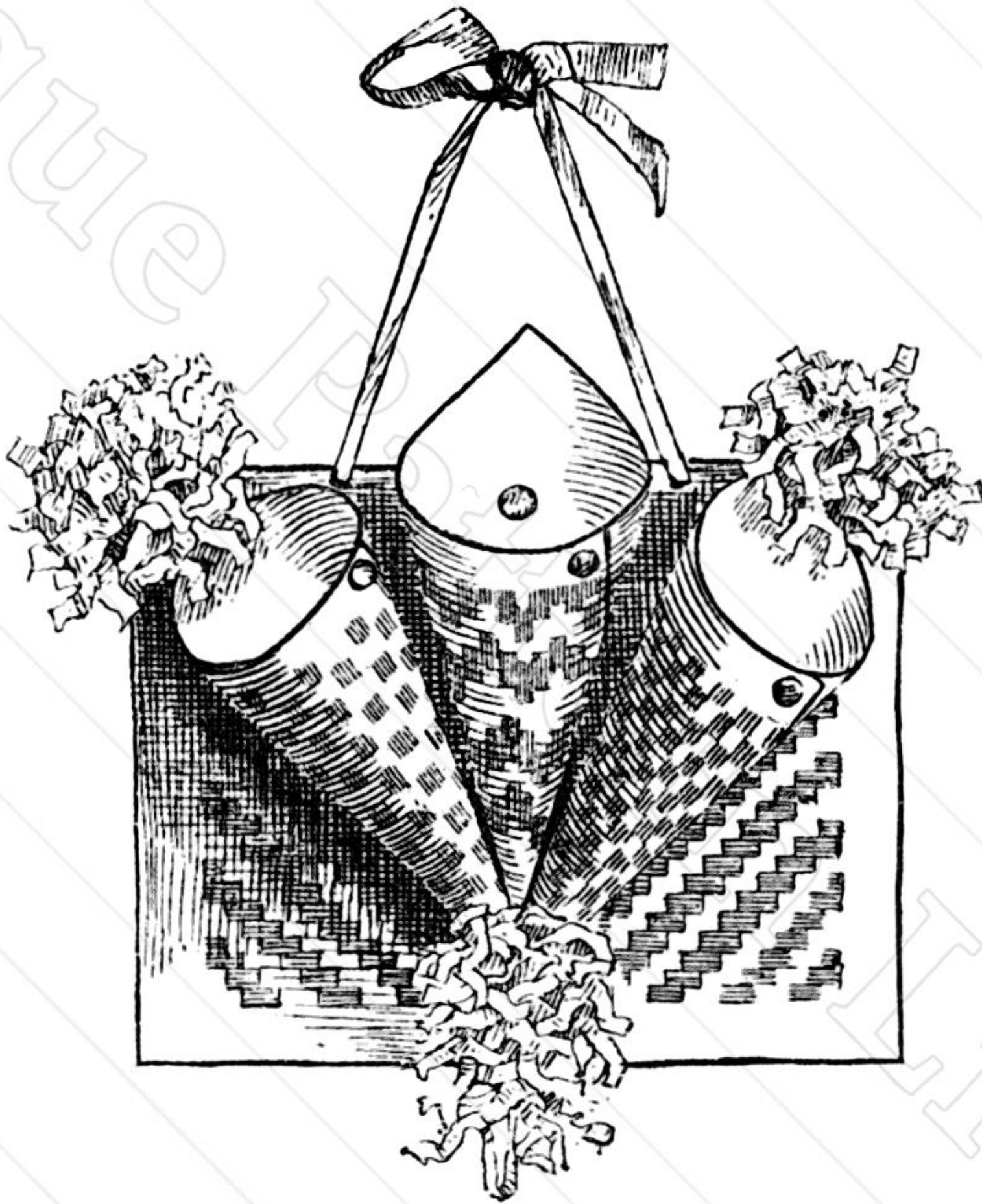

FIG. 17.—Toilet Tidy.

Colours.—White mats and pale yellow strips, ribbon, and rosettes.

FLOWER VASE

Four mats are required for this object. Paste the four separately upon pink-tinted cardboard, and leave under a weight to dry. When dry, cut each to the shape of diagram, which exactly fits the mat *without cutting the weaving.*

Join the sides together by pricking holes $\frac{1}{4}$ inch apart, and sew up and back again to form a cross stitch. This joining can be done by the children with the exception of the last side, which the teacher must join, and also sew in a 4-inch square to form the bottom.

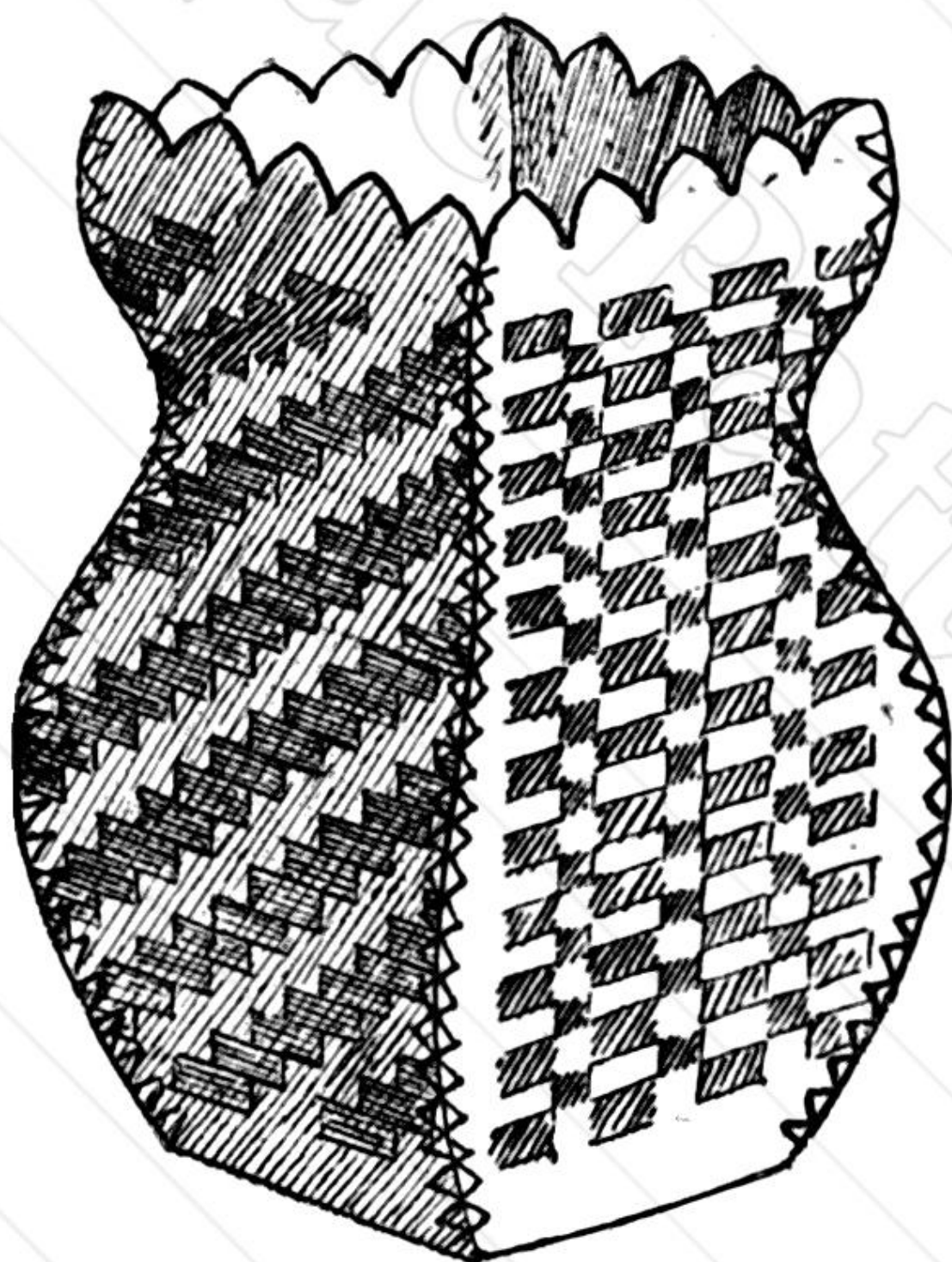

FIG. 18.—Flower Vase.

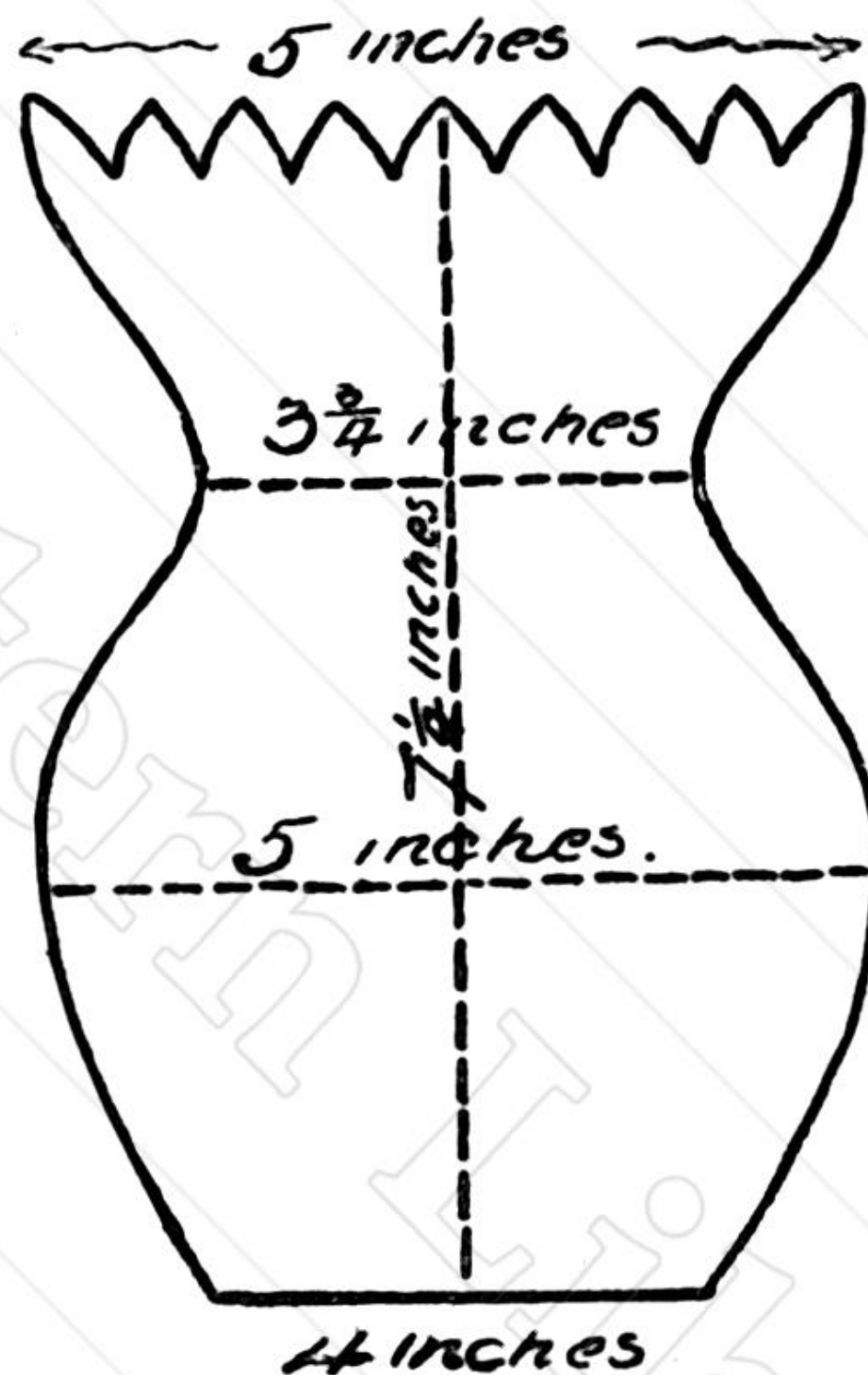

FIG. 19.

The upper edge may be finished with a cut ruche of crinkled paper, or be snipped in points, as in Fig. 18.

Colours.—Brown and pink.

When finished the sides must be pressed open and the lower portions forced out, as in Fig. 18.

HEXAGONAL FLOWER-POT COVER

Colours.—White mats and yellow strips.

Six mats are required to make this cover. Paste the mats $\frac{1}{8}$ inch apart upon a continuous strip of cardboard $7\frac{1}{4}$

UTILITY OF MATS

23

inches wide. Crease outwards the cardboard between each mat, and fold up and place under a weight to dry. Cover each crease, and top and bottom, with ruches of crinkled

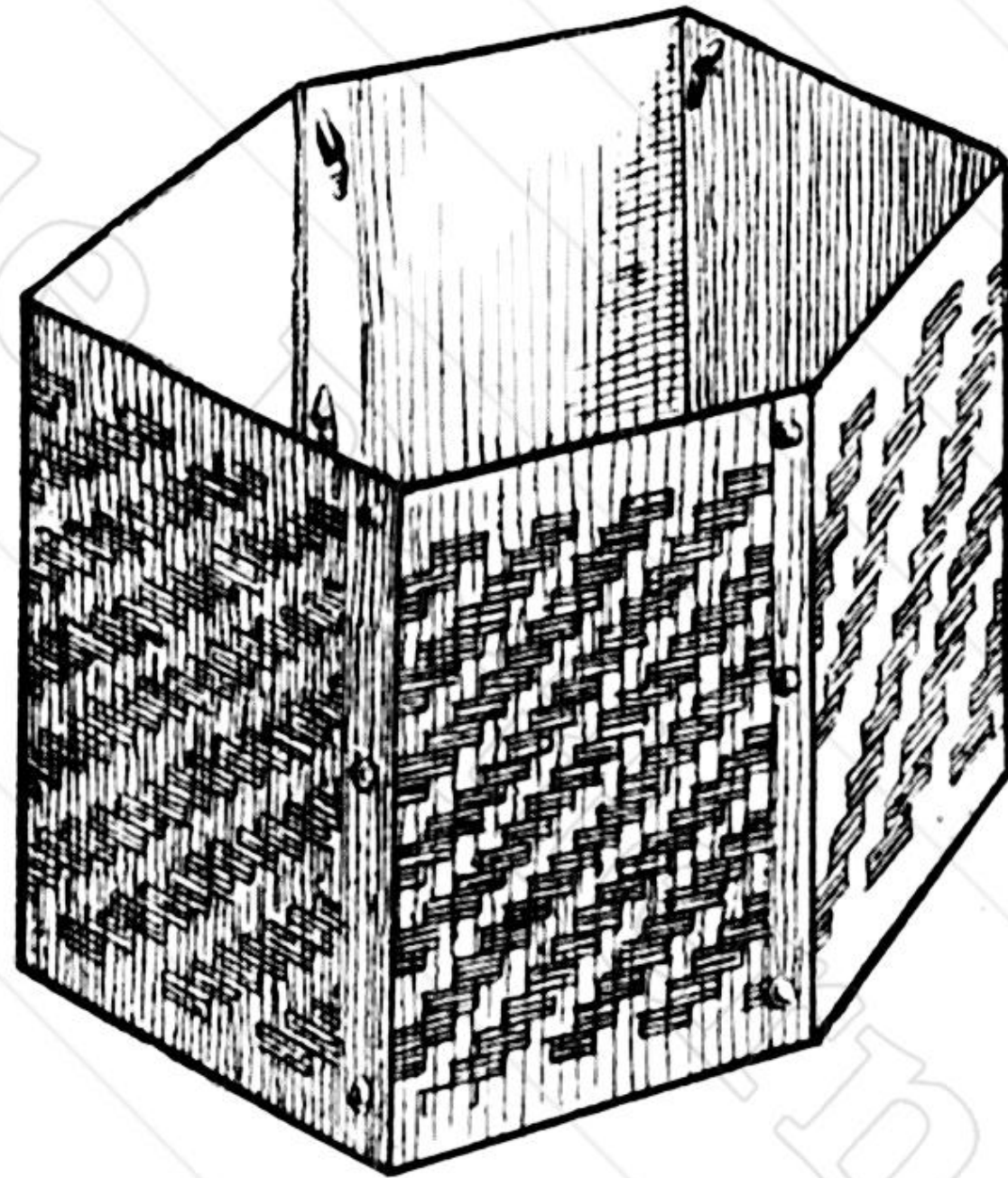

FIG. 20.—Hexagonal Flower-pot Cover.

paper, and fasten together in hexagonal shape. Or mount each mat separately, and then overlap and fasten borders together with brass-headed fasteners, as in Fig. 20.

FOURFOLD FIRE-SCREEN

This is a very good and simple method of using the mats. The screens are useful for showing the various patterns taught during the year, and they form a pleasing reminiscence when used as fire-screens in school during the summer months. Cut four strips of stout cardboard 27 inches long and 10 inches wide. Arrange the mats evenly, with a margin of $1\frac{1}{2}$ inches round each.

Join the four strips of cardboard together at the back,

by "glueing" or "gumming" strips of unbleached calico down the three openings. The sides must not be quite

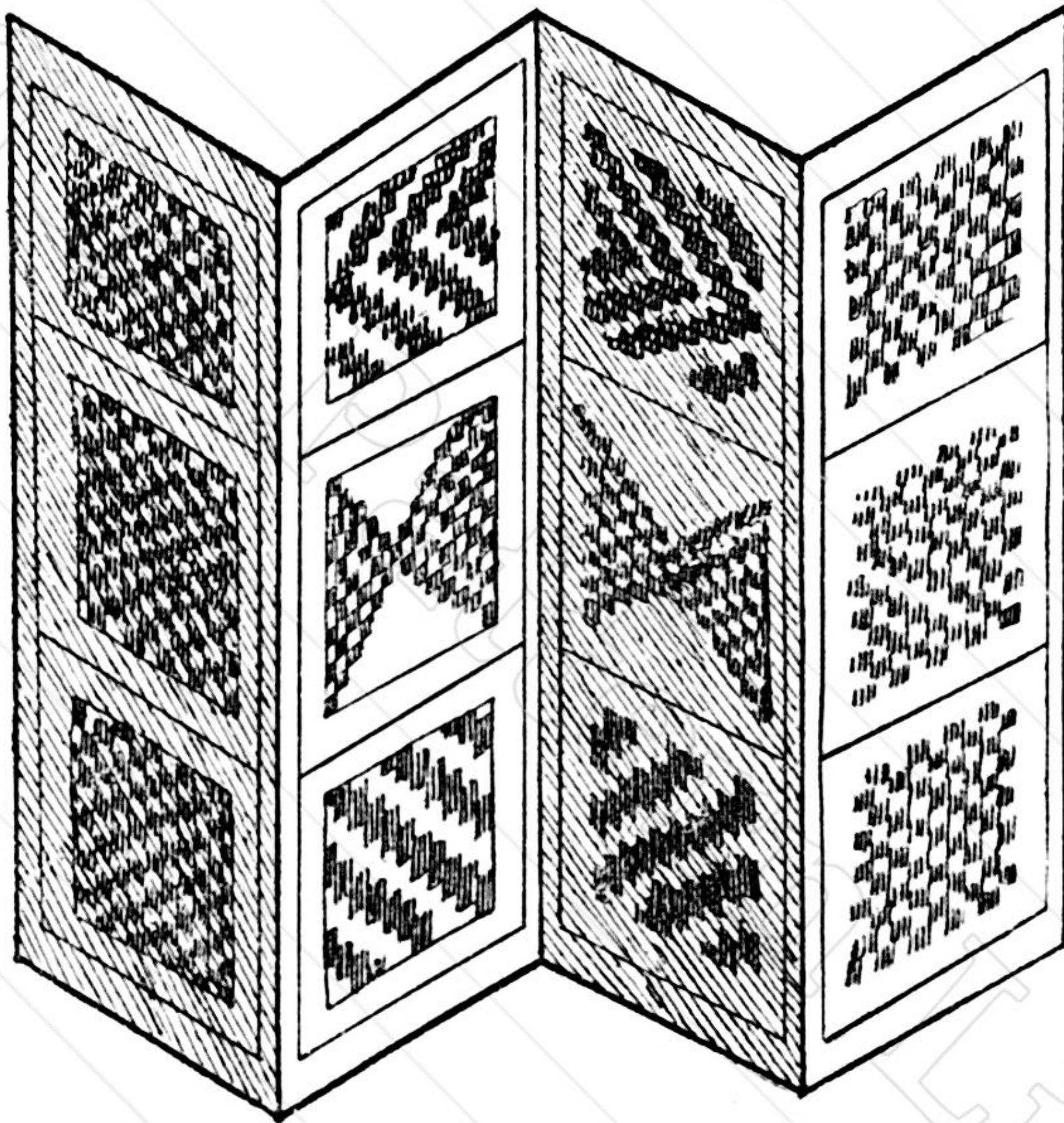

FIG. 21.—Fourfold Fire-screen.

close together, but sufficiently apart that the calico may act as a hinge, and allow the screen to be folded or unfolded.

STAGE III.

This stage is the most advanced in mat-plaiting, and is suitable for upper infants, or for children who have passed through Stages I. and II.

The mats used in this stage consist of very fine strips, which will need delicacy of touch in weaving. The patterns will be more complicated and advanced in difficulty, and

UTILITY OF MATS

25

comprise numbers 1-5 in the formation of the designs. At this stage it is desirable to cultivate in the children an artistic taste in the choice of colours. All crude primary colours should be avoided, and preference be given to the combinations of soft neutral tints and art shades. These colours are procurable at the best Kindergarten depôts, and the designs, when finished, are most effective. Children at this stage should thoroughly understand the theory of their occupation, and a lesson upon weaving should be given. Show picture of a loom, and tell children that the threads which run from end to end of a piece of cloth are called the "warp," and the threads which run across from selvedge to selvedge are known by the name of "weft" or "woof." The threads of the weft are wound round the shuttle which weaves across the "warp." Draw the following comparison between the mat and the loom :—

- Comparison.*—(1) The frame of loom to border of mat.
 (2) The warp threads to the tight strips.
 (3) The weft threads to the loose strips.
 (4) The shuttle to the plaiting needle.

The chief difference between this and the previous stage is that the patterns are dictated or written on the black-board by the teacher, and thus great concentration is brought into the work because the children are intent upon the development of the pattern. The mats are used in duplicate, as in Stage II., and patterns taught upon the stiff class mat are reproduced upon the corresponding thin mat. Children should be allowed to choose their own colours, and invent, reverse, and contrast patterns. Using strips of different colours and widths will vary the effect of the patterns considerably.

How to Make a Mat of any Shape.—Teachers may, with a little ingenuity, produce any shaped article in mat-plaiting.

The shape should first be drawn and cut out. The outline should again be traced half an inch from the edge to form the border of the mat. The inner space is then marked off in $\frac{1}{4}$ -inch spaces, and with ruler and sharp pen-knife vertical strips are cut, and afterwards woven. The toilet tidy is an article made in this way.

TOILET TIDY

It is drawn and cut from a sheet of thin tinted cardboard. It consists of two pieces. The outline is drawn

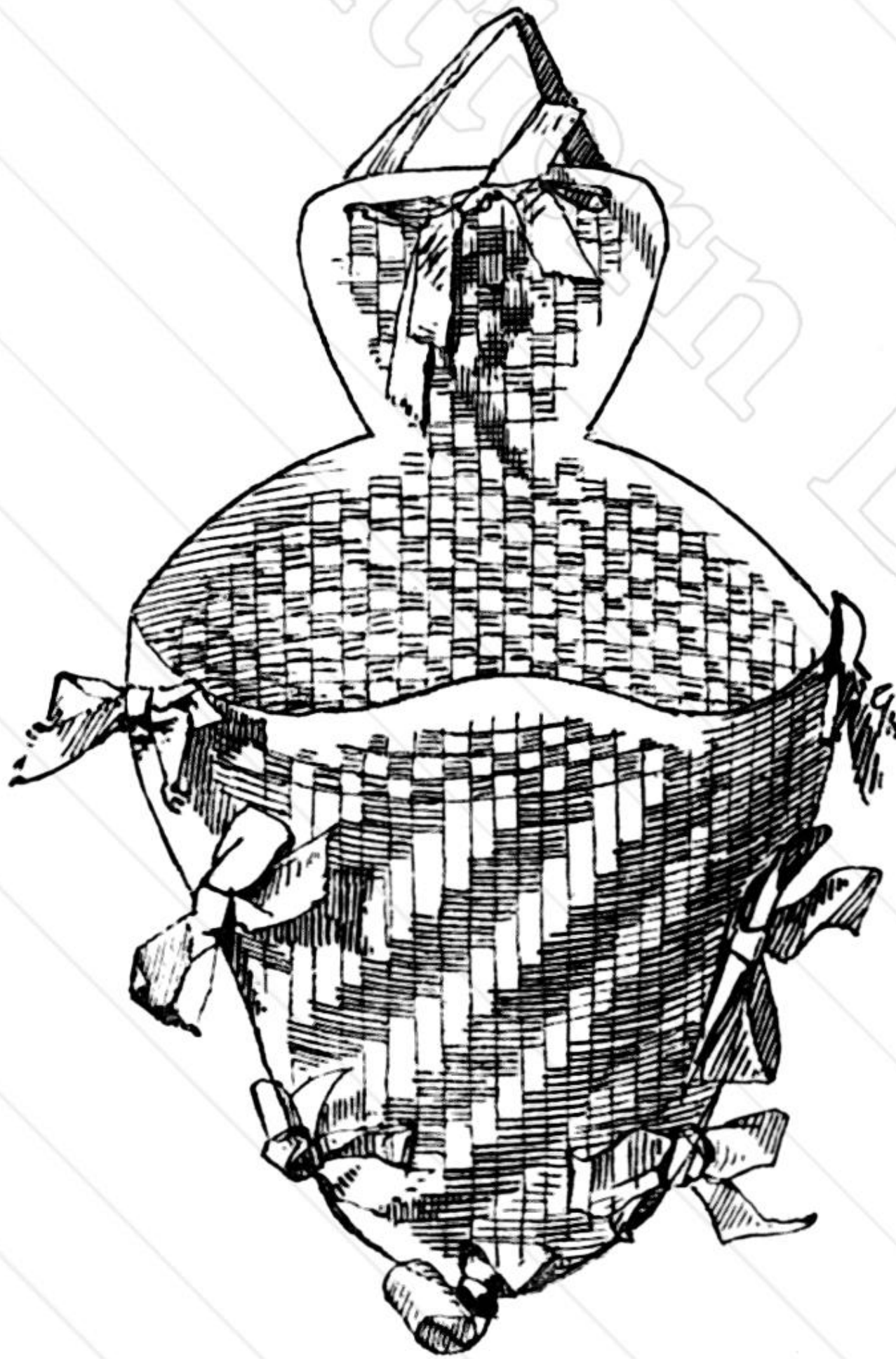

FIG. 22.—Toilet Tidy.

UTILITY OF MATS

in pencil and cut out, and a margin of half an inch from

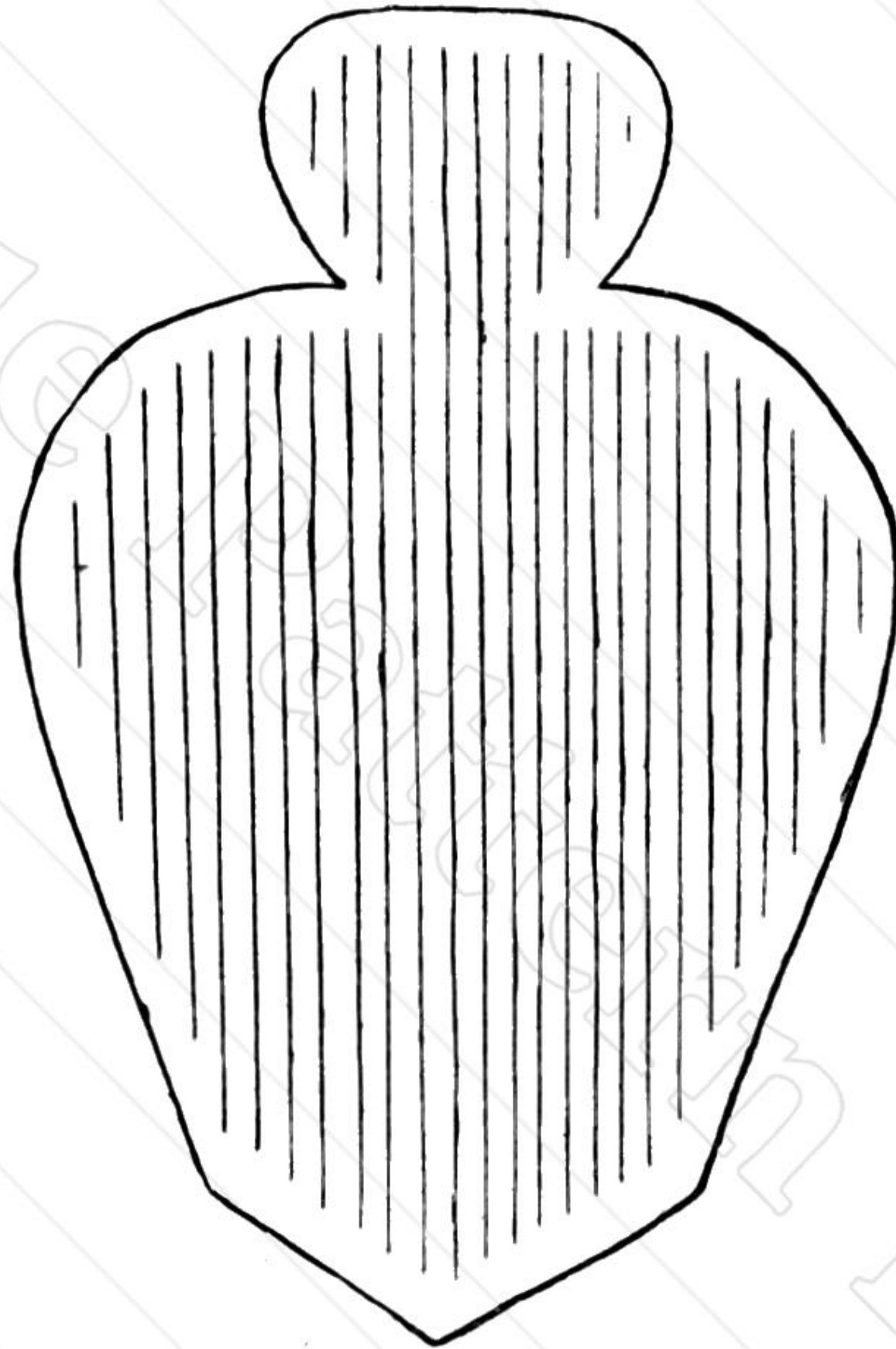

FIG. 23.

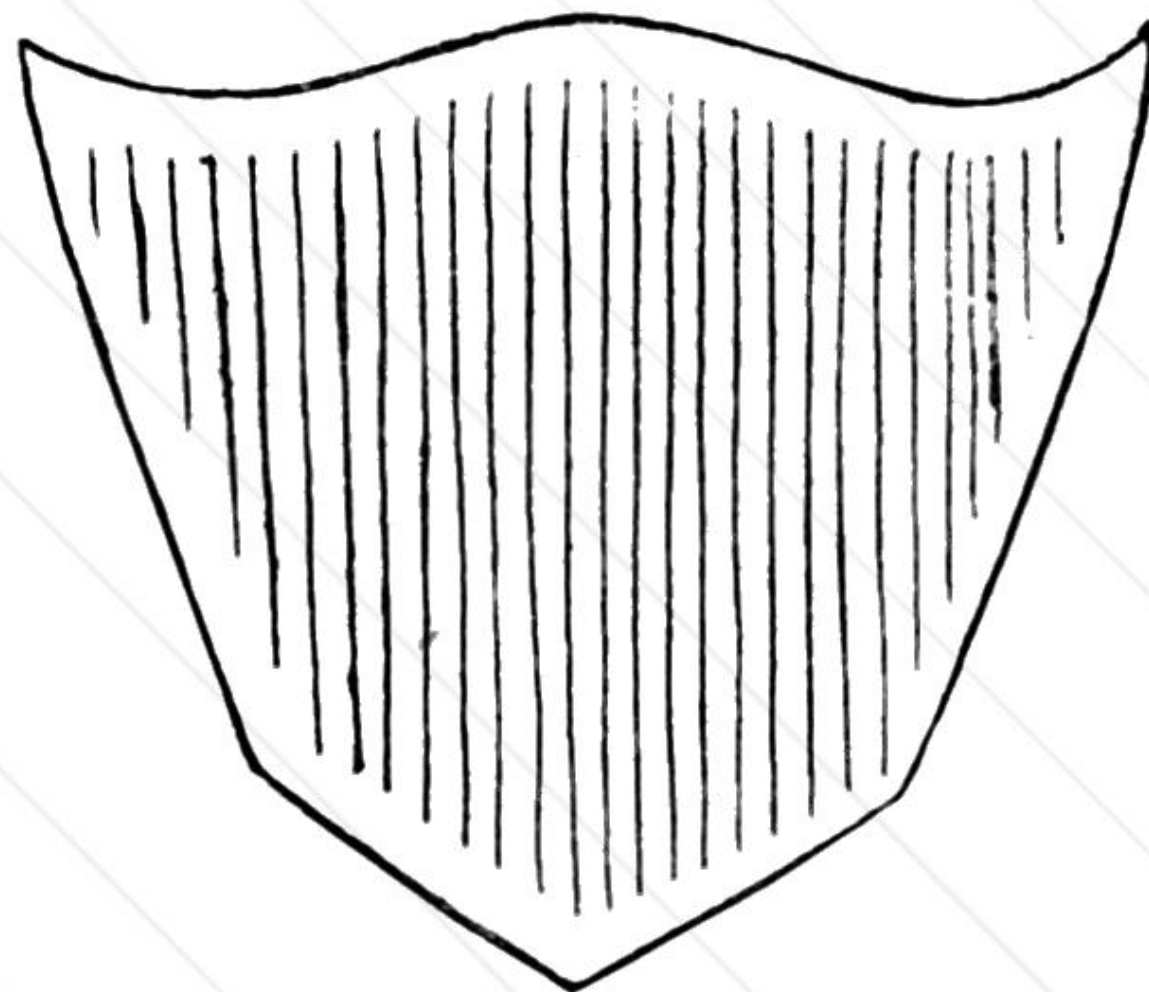

FIG. 24.

the edge is left to form the border of the mat. The inner

space is then ruled in lines an eighth of an inch apart, and cut with a sharp penknife. Each portion is treated in the same way, and afterwards woven by the children. Punched holes and bows of ribbon tie the parts together.

PATTERNS FOR STAGE III.

The following patterns illustrate various exercises which have been dictated in successive lessons, and reproduced in entirety upon the thin mat. To reverse a pattern children simply have to copy from the wrong side of their mats.

PATTERNS 1, 2, 3

No. 1

First Row.—3 down, 3 up.

Third Row.—1 down, 1 up.

Second Row.—3 up, 3 down.

Fourth Row.—1 up, 1 down.

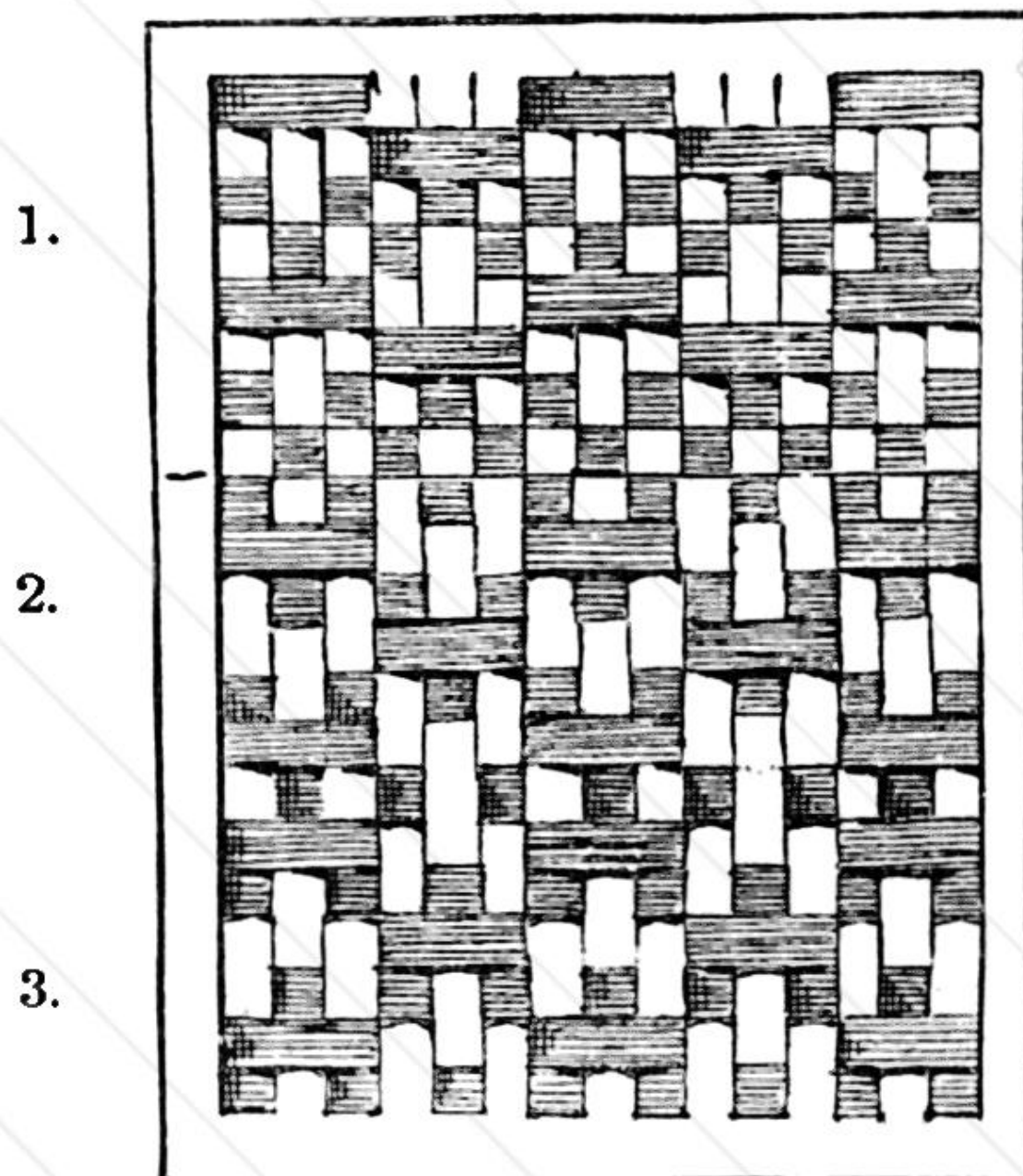

FIG. 25.—Patterns 1, 2, 3.

UTILITY OF MATS

No. 2

First Row.—1 down, 1 up.

Second Row.—3 down, 3 up.

Third Row.—1 up, 1 down.

Fourth Row.—3 up, 3 down.

No. 3

First Row.—1 up, 1 down.

Second Row.—3 down, 3 up.

Third Row.—1 down, 1 up.

Fourth Row.—3 up, 3 down.

PATTERNS 4, 5

No. 4

First Row.—3 down, 1 up, 5 down, 1 up. Repeat.

Second Row.—2 down, 1 up, 1 down, 1 up, 3 down. Repeat.

Third Row.—1 down, 1 up, 3 down, 1 up. Repeat.

Fourth Row.—1 up, 5 down, 1 up, 5 down. Repeat.

Fifth Row.—Same as third.

Sixth Row.—Same as second.

Seventh Row.—Same as first.

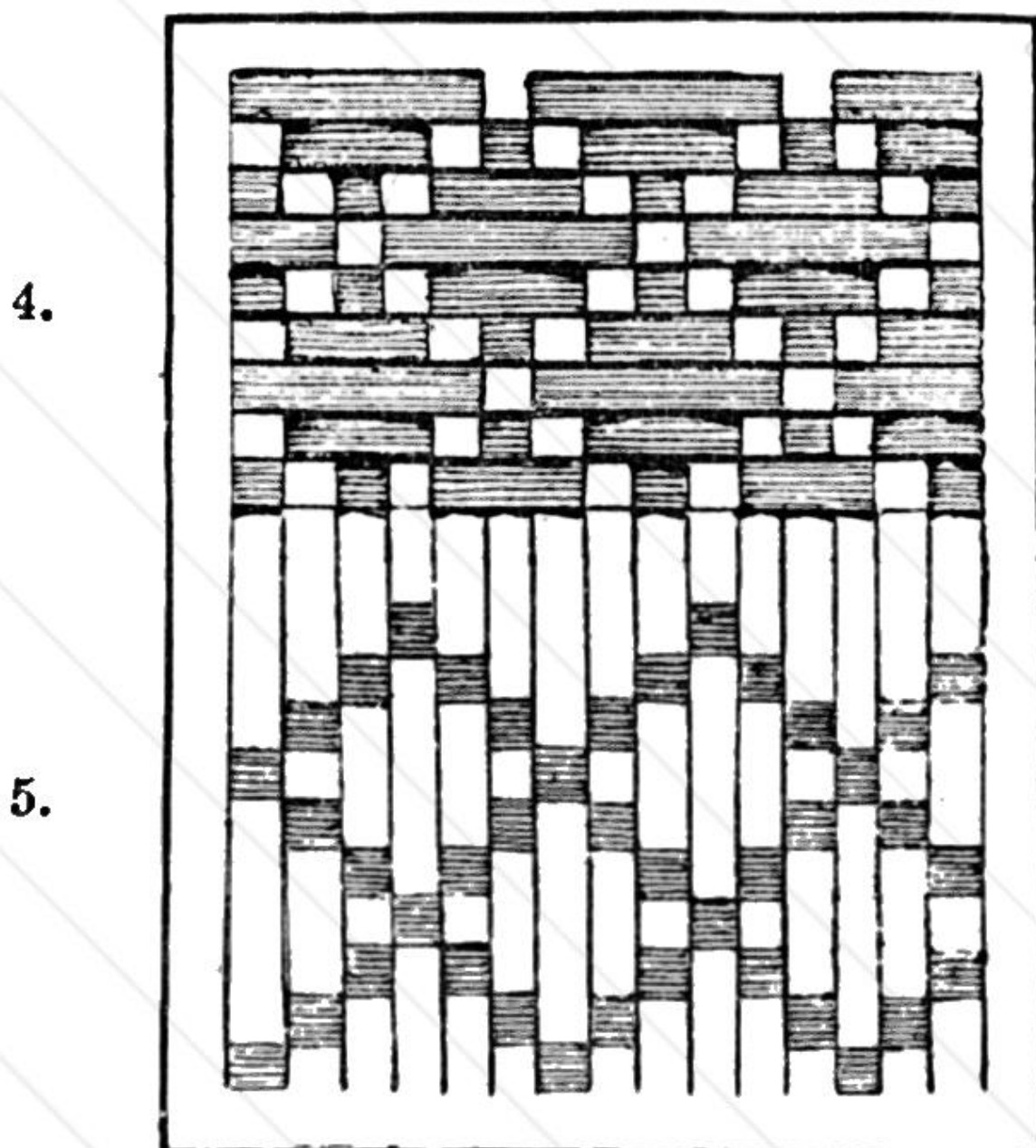

FIG. 26.—Patterns 4, 5.

No. 5

<i>First Row.</i> —5 up, 1 down. Repeat.	<i>Fourth Row.</i> —2 up, 1 down, 5 up. Repeat.
<i>Second Row.</i> —1 down, 3 up, 1 down, 1 up. Repeat.	<i>Fifth Row.</i> —Same as third.
<i>Third Row.</i> —1 up, 1 down, 1 up, 1 down, 3 up. Repeat.	<i>Sixth Row.</i> —Same as second.
	<i>Seventh Row.</i> — Same as first.

PATTERNS 6, 7, 8

No. 6

<i>First Row.</i> —3 down, 3 up. Repeat.	<i>Fourth Row.</i> —3 up, 3 down. Repeat.
<i>Second Row.</i> —1 down, 1 up. Repeat.	<i>Fifth Row.</i> 1 up, 1 down. Repeat.
<i>Third Row.</i> —Same as first.	<i>Sixth Row.</i> —Same as fourth.

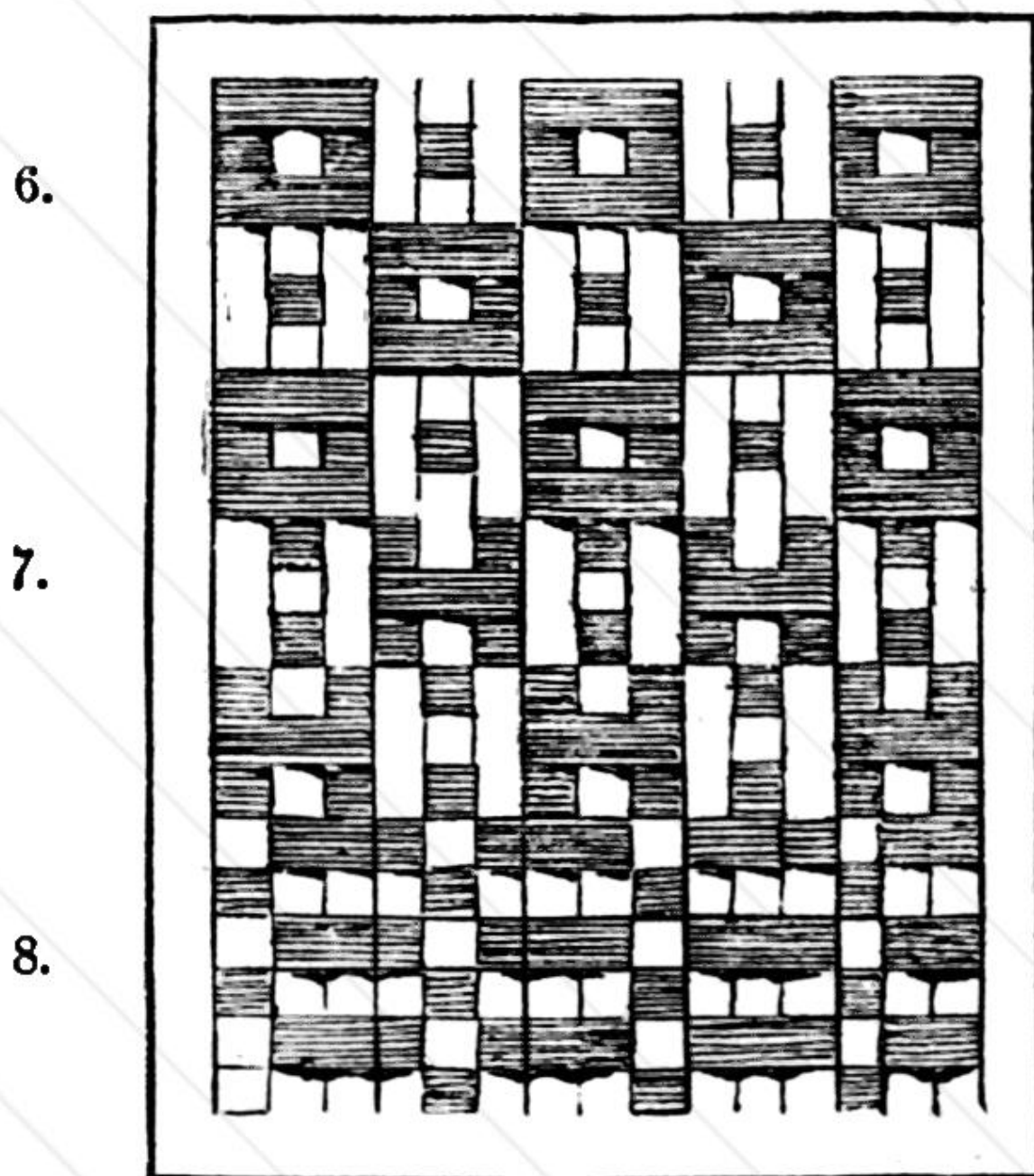

FIG. 27.—Patterns 6, 7, 8.

UTILITY OF MATS

No. 7

First Row.—1 up, 1 down. *Fourth Row.*—1 down, 1 up.
Repeat. Repeat.
Second Row.—3 up, 3 down. *Fifth Row.*—3 down, 3 up.
Repeat. Repeat.
Third Row.—Same as first. *Sixth Row.*—Same as fourth.

No. 8

First Row.—3 down, 1 up. *Second Row.*—3 up, 1 down.
Repeat. Repeat.

PATTERNS 9, 10, 11

No. 9

First Row.—1 up, 1 down, 1 up, 3 down. Repeat.
Transfer the pattern one strip to left for three succeeding rows.

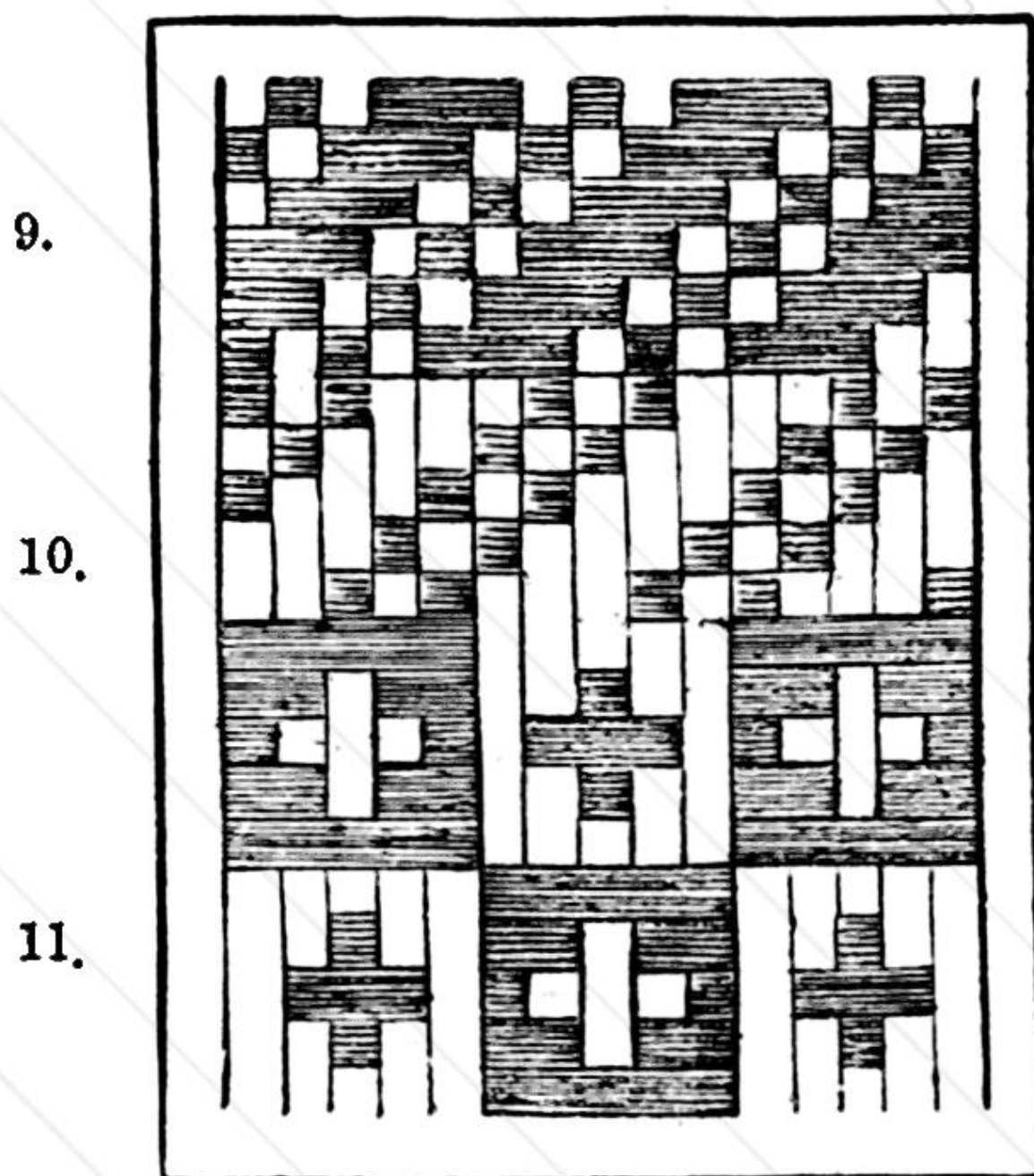

FIG. 28.—Patterns 9, 10, 11.

No. 10

First turn mats over and copy No. 9 from the wrong side.

No. 11

<i>First Row.</i> —5 down, 5 up.	down, 1 up, 3 down, 1 up,
<i>Second Row.</i> —2 down, 1 up,	1 down, 3 up, 1 down.
2 down, 2 up, 1 down,	<i>Fourth Row.</i> —Same as second.
2 up, 2 down, 1 up, 2	<i>Fifth Row.</i> —Same as third.
down.	For 6, 7, 8, 9, 10 rows
<i>Third Row.</i> —1 down, 3 up, 1	alternate pattern.

PATTERNS 11, 12, 13

The patterns given in this illustration are so plain as to need no explanation.

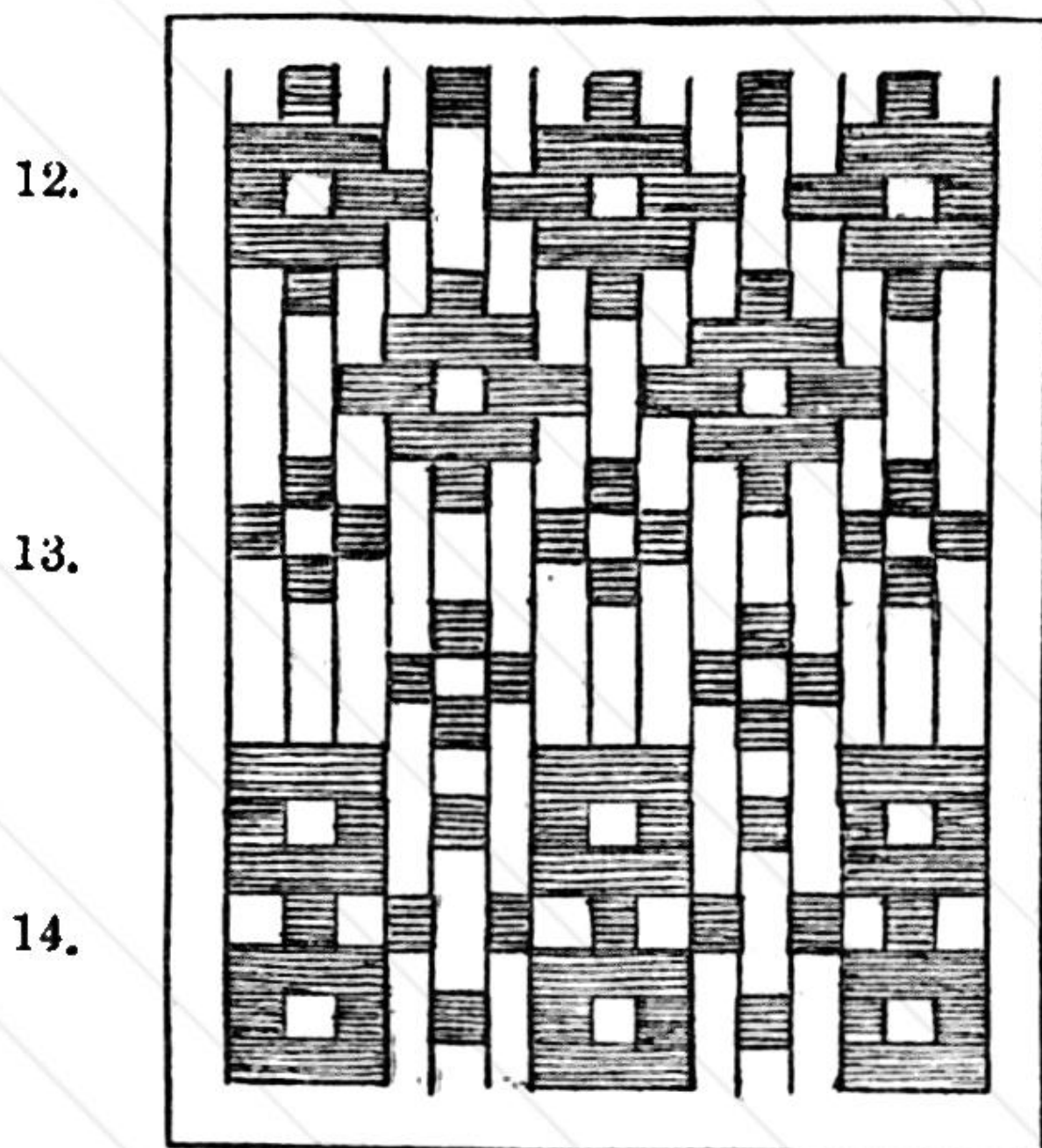

FIG. 29.—Patterns 11, 12, 13.

USEFUL APPLICATION OF THE MATS

The mats of this stage having fine strips, the designs are consequently smaller and suitable for cutting to various shapes. The mats must first be prepared by pasting them entirely over on the under side with tissue paper, or mounting them upon tinted cardboard, which can be bought in packets ready gummed, and need only moistening with a damp sponge before placing on the mat.

Prepare a number of mats in this way, and place under a weight to dry in a perfectly flat position. This done, the mats have now to be cut to the desired shape, and the edges finished by binding them in ribbon or a strip of gummed paper.

PEN-WIPERS AND NEEDLE-BOOKS

The following shapes :—Butterfly, fan, heart, and bellows are very suitable for pen-wipers and needle-books.

Mount the mats on tinted cardboard, and cut two of each shape for each article, bind the edges with narrow ribbon, insert snipped leaves of cloth or flannel, and tie together with ribbon.

SLIPPER POCKET

Two mats are required for the entire slipper. The pattern can be cut from an ordinary oblong mat. Place the pattern diagonally upon the mat, and let the heel portion cover the weaving, without the border, as this is the part that will show when finished. The toe will reach

D

to the edge of border opposite, but this will not signify, as the toe-cap will hide it. Cut out both portions and bind the edges with narrow ribbon or paper. Sew on the toe-cap, and add a loop of ribbon at the heel. Two shoes alike should go together as a pair.

SERVIETTE RING

A pretty present of six different rings in a cardboard box may be easily made of mats.



FIG. 30.—Slipper Pocket.

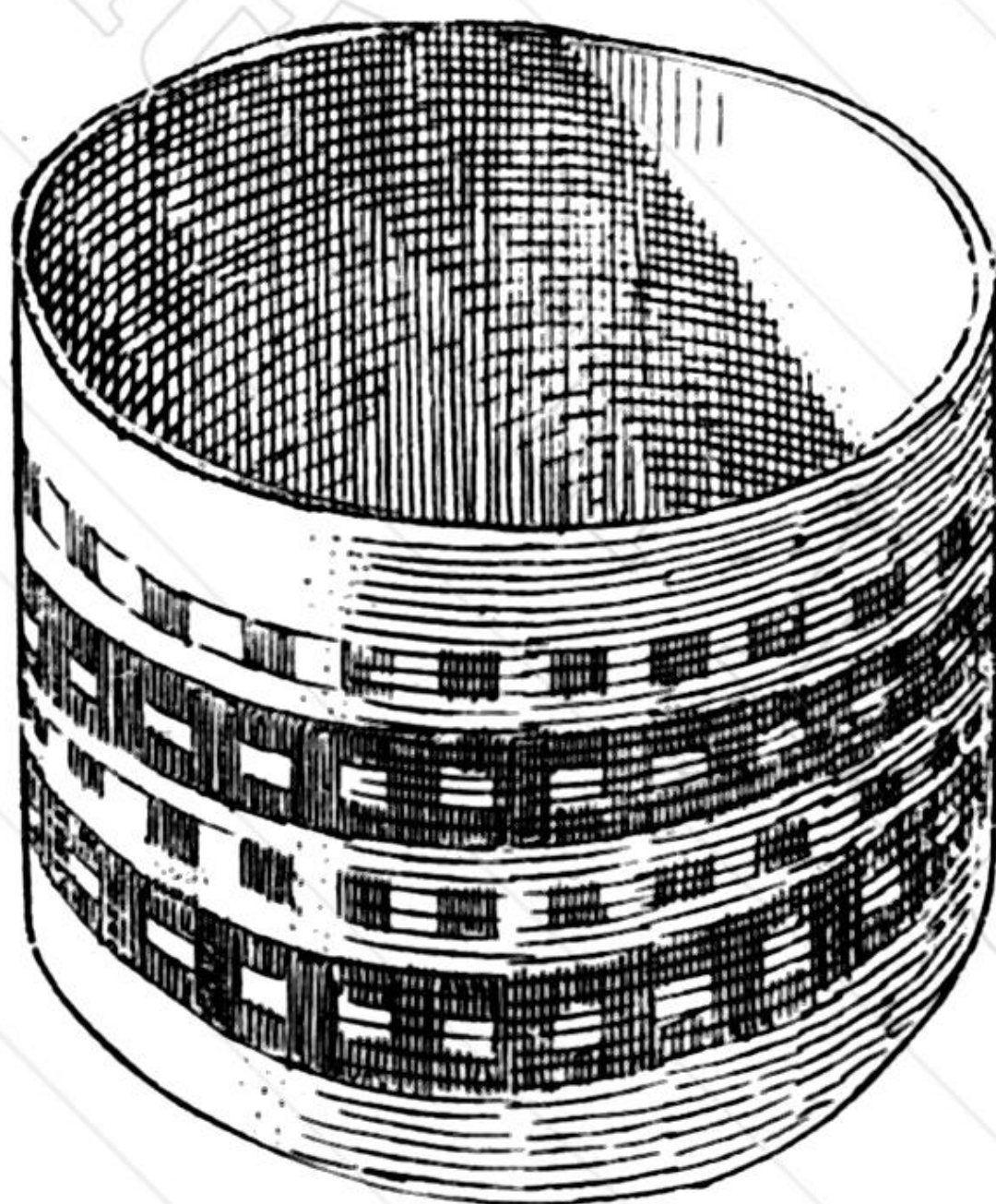

FIG. 31.—Serviette Ring.

Procure a Seidlitz-powder box, and ornament the top with a pretty mat; the rest of the box will do, as it is white with gold stars.

The rings are made from twelve centre strips of a No. V. mat. The two outer strips form the border and the other ten strips are woven. The strip when finished is mounted

on thin cardboard, and fastened into a circular form whilst damp, by two paper fasteners, and ornamented with bow of ribbon to harmonise in colour. Place all six in the box with the bows uppermost.

CARD BASKET

This consists of seven irregular hexagons, each one bound with narrow ribbon to harmonise with mat. A regular

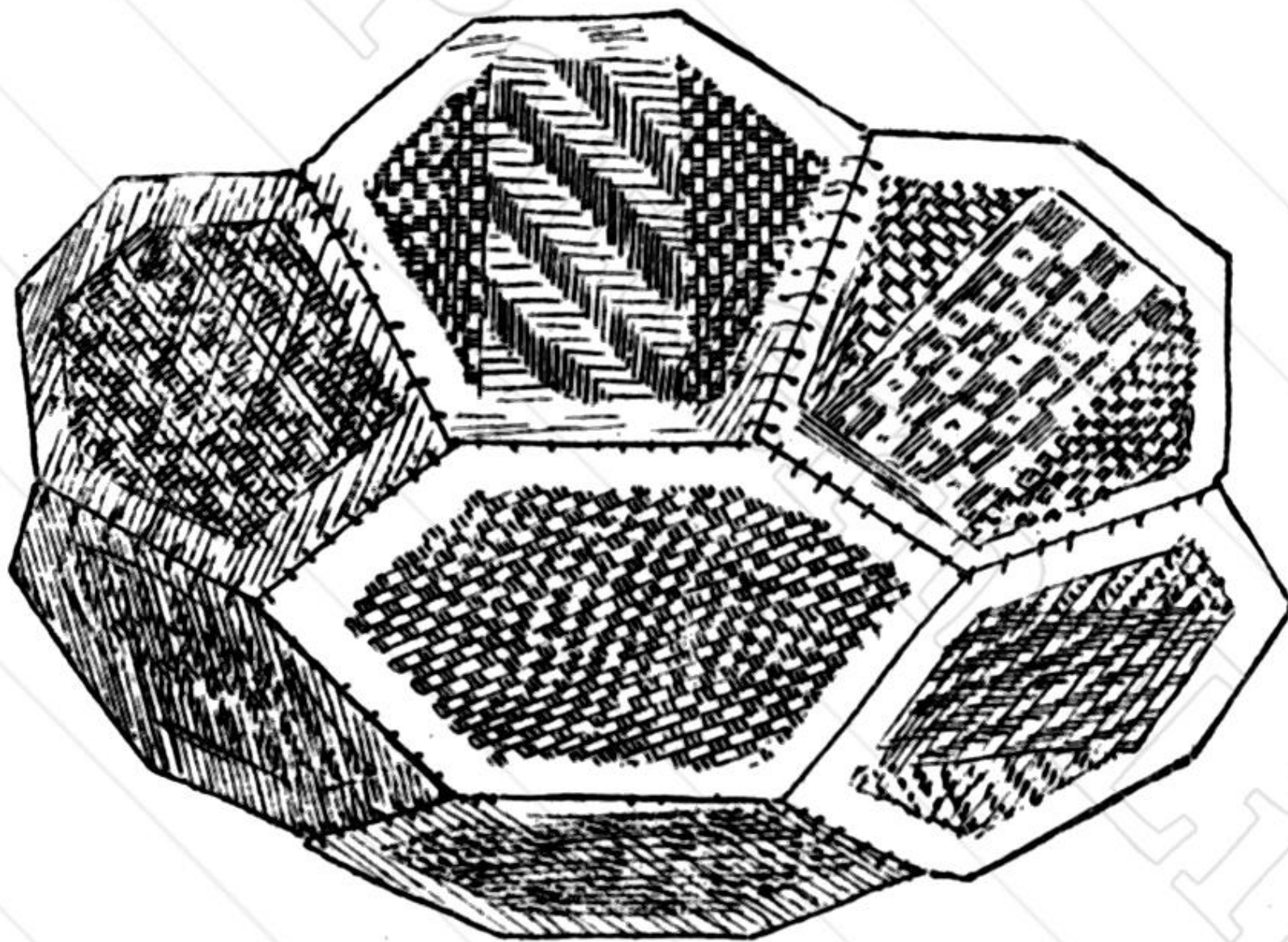

FIG. 32.—Card Basket.

hexagon forms the bottom and the others are sewn round it. Small mats with border suitable for this basket are sold in packets by Messrs. Newman and Co., Berners Street, W. They simply need mounting and tying together with ribbon, and thus the necessity of binding is avoided.

VASE FOR PAMPAS-GRASS OR UMBRELLAS

This is a very easy method of using up a quantity of mats. Prepare the mats with tissue paper as before

directed, and cut them into any convenient shape, such as

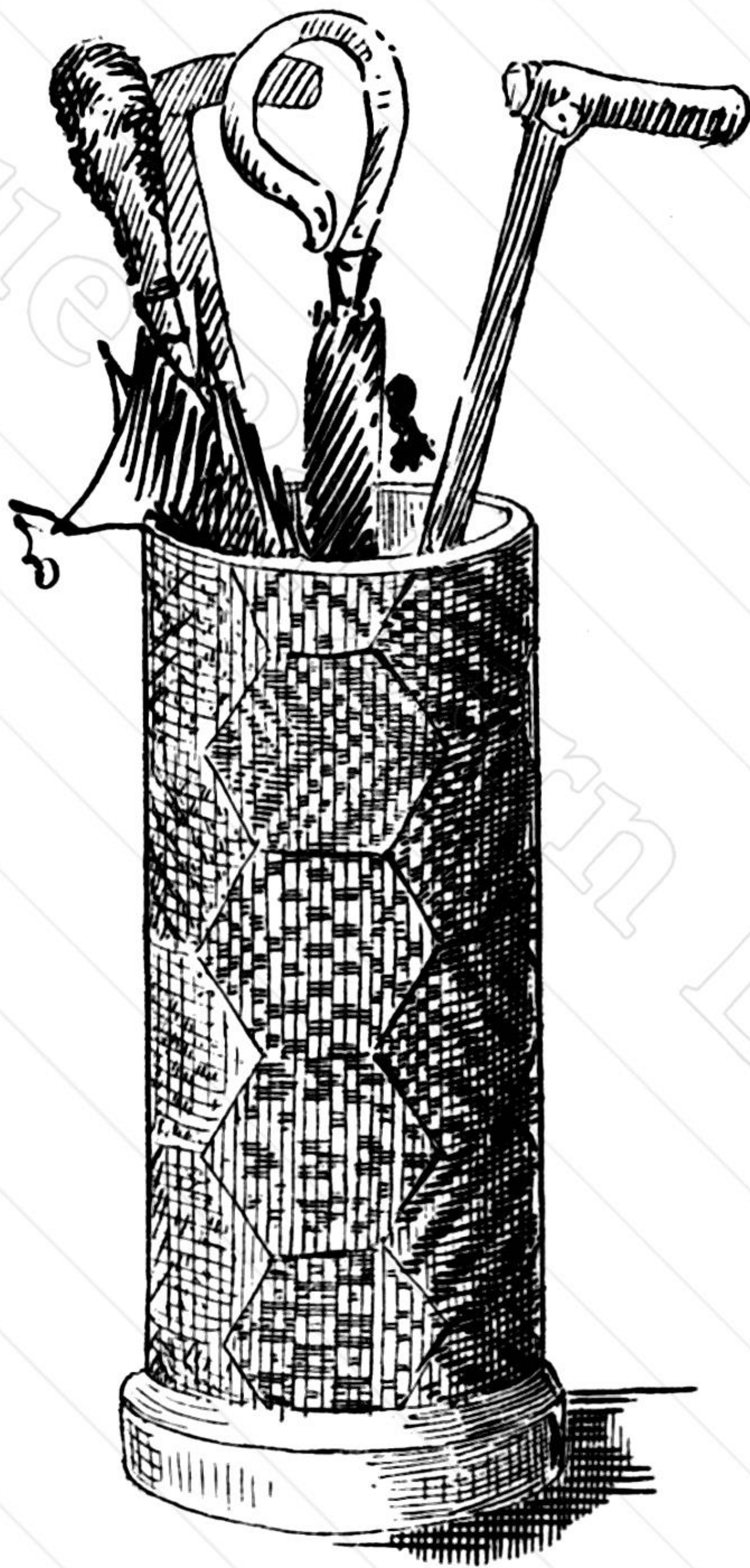

FIG. 33.—Vase for Pampas-grass or Umbrellas.

squares, diamonds, rhomboids, or hexagons. Have ready a sheet of stout cardboard (18 in. by 22 in.), cut to the size

OPEN WEAVING

37

of an ordinary drain-pipe. Lay the cardboard flat on the table, and paste on the hexagons in patchwork form, arranging the colours to form a harmonious combination. As each hexagon is laid in position, place a flat-iron or other weight upon it whilst fixing the next, and so on till the cardboard is covered. Finish the joins by pasting across strips of narrow gold or silver paper. Or if desired, the hexagons may be placed to touch at the corners only, and show a plain hexagon of the tinted cardboard and alternate with one of mat-plaiting, then no binding will be needed. Join the cardboard ends together, and fasten neatly with large brass paper fasteners, or paste a strip of calico down the join inside. If filled with pampas-grass it is a pretty decoration for a corner of a room. A round bottom may be glued in, and three or four large cotton reels enamelled and fastened on for legs.

If an ordinary drain-pipe be procured, the mats can be pasted on in crazy patchwork style, and, well sized and varnished, will become a durable and handsome mosaic-looking stand for a hall or room.

OPEN WEAVING

This work is a very pleasant change for the proficient weavers. The patterns are geometrical, and open in construction, and the weaving interlaces the tight strips first horizontally and then diagonally.

The beauty of the work lies chiefly in the open spaces which are left in the plaiting, and which, when filled in with a contrasting coloured lining, adds to the effect of the weaving.

The materials used for teaching are the ordinary paper

Mats III. and IV., with needles and loose strips. The latter require to be 7 or 9 inches long for the longest diagonals.

Square mats are best for the purpose, because the children may be taught, without difficulty, the meaning of diagonal, and the weaving would be less puzzling than upon the oblong mat. However, oblong mats can be successfully used for the work, but the centre diagonal will not run from corner to corner, as it would in the square mat.

The illustrations are copied from Mat IV., an oblong mat of fifteen tight strips. The illustrations show the *right* side of the mat.

LESSON I

PREPARATION OF MAT

Materials required.—Give each child (1) a white paper mat ; (2) a pair of paper scissors ; and (3) a small piece of blotting-paper.

Note.—Mats should have the borders ready gummed before distribution ; if not bought ready prepared, the teacher should do this herself, as it is not practicable to have a large class of infants using wet gum without spoiling the greater portion of the work.

Plan of Lesson.—The strips should next be counted (fifteen). Children to name how many threes in fifteen, and with unthreaded needles to “lift” *three* up and *one* down across the mat.

Let them raise the needle slightly, about one inch from the top of the mat, and hold in position until teacher has inspected the class.

This done, the children will cut through the strips *upon*

OPEN WEAVING

39

the needle, and afterwards cut them away quite neat and even with the border, top and bottom. Three strips will be cut away four times in the mat referred to, which should present the appearance of Fig. 34.

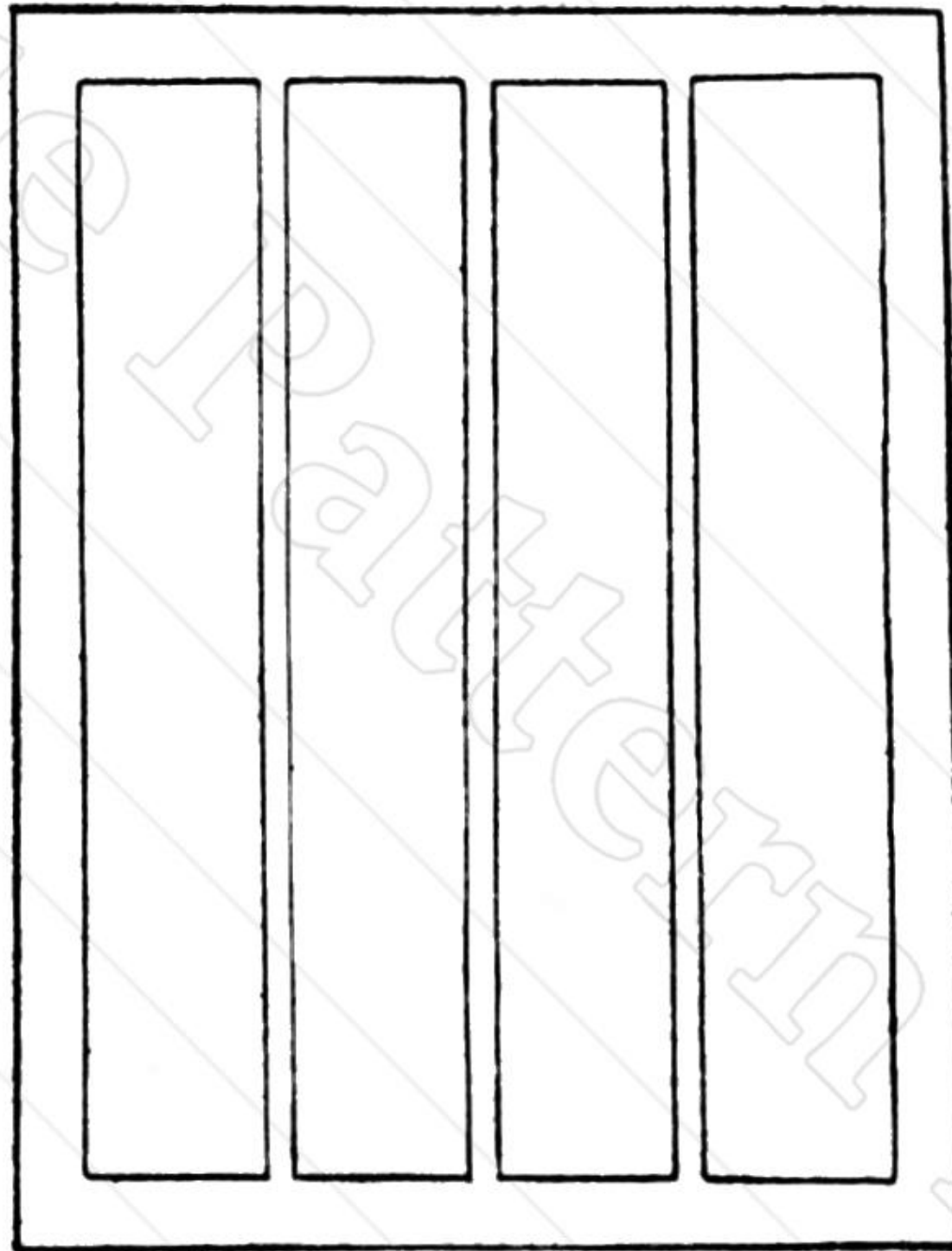

FIG. 34.

HORIZONTAL CROSSING

Turn mats right side downwards with the gummed side uppermost, and let the children use strips of another colour, *e.g.* "red."

Five strips are now laid horizontally across the mat about three-quarter inch apart, to form squares with the vertical strands.

Children should give the definition of a square, and, if necessary, they might measure and mark the spaces with ruler and pencil before fixing their strips.

It is better *not* to weave the horizontal strips, but simply lay them across at right angles to the vertical ones, and with a damp sponge or slightly moist finger wet the border,

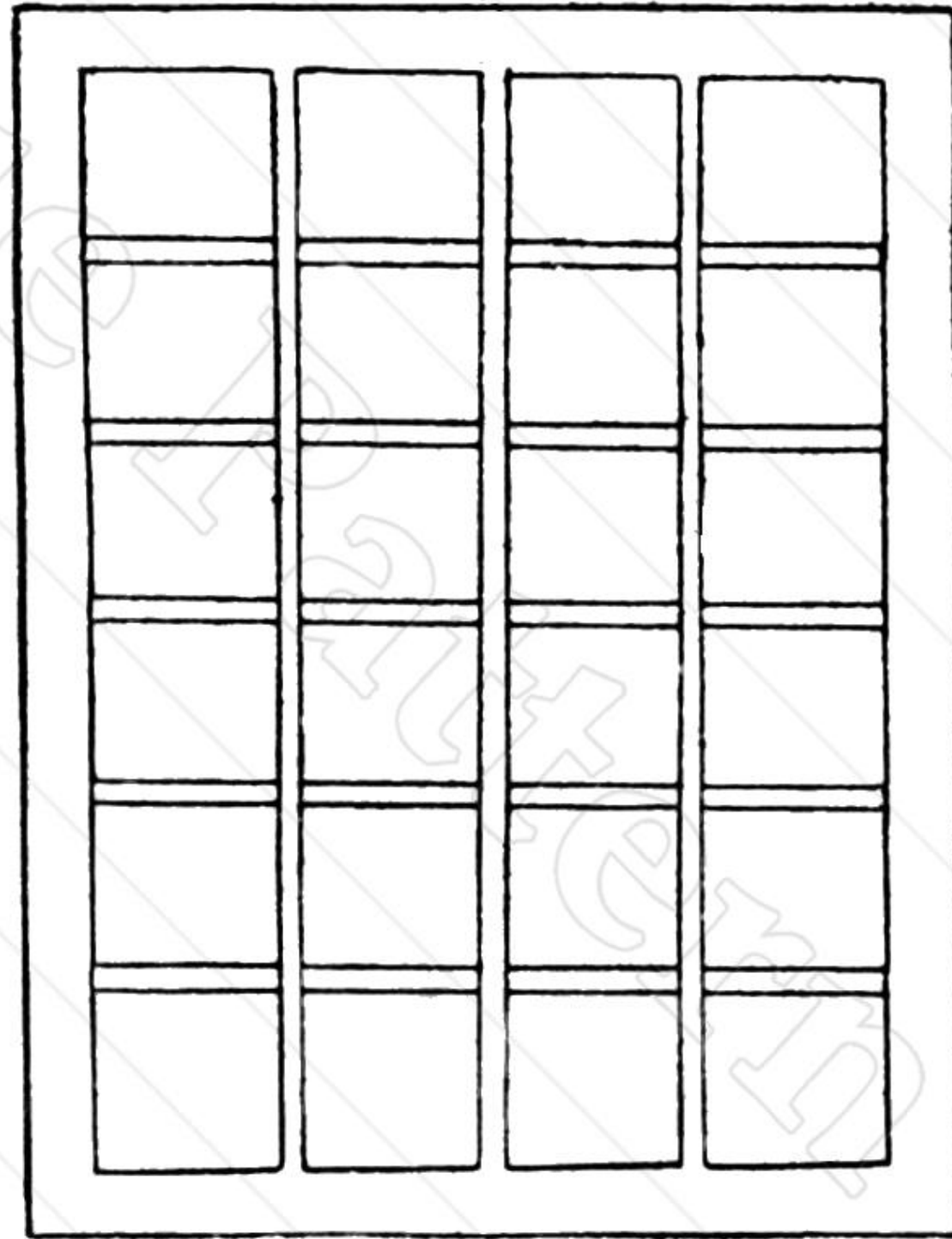

FIG. 35.

and fix each strip in position, pressing the part with the blotting-paper.

This preparation will form one lesson. The mats must be collected with the blotting-paper between each and placed under a weight till dry.

DIAGONAL WEAVING

LESSON II

Give children a lesson upon the "diagonal," and illustrate upon blackboard and show what is meant by the

DIAGONAL WEAVING

41

diagonal in geometrical figures. Children to repeat "A diagonal is a line passing through opposite angles."

Children to touch the angles of their mat, and show the course a diagonal would take. Turn mats with gummed borders underneath, and examine the strips already upon the mat. Children will soon notice that all verticals are up and horizontals down, and as previous weaving

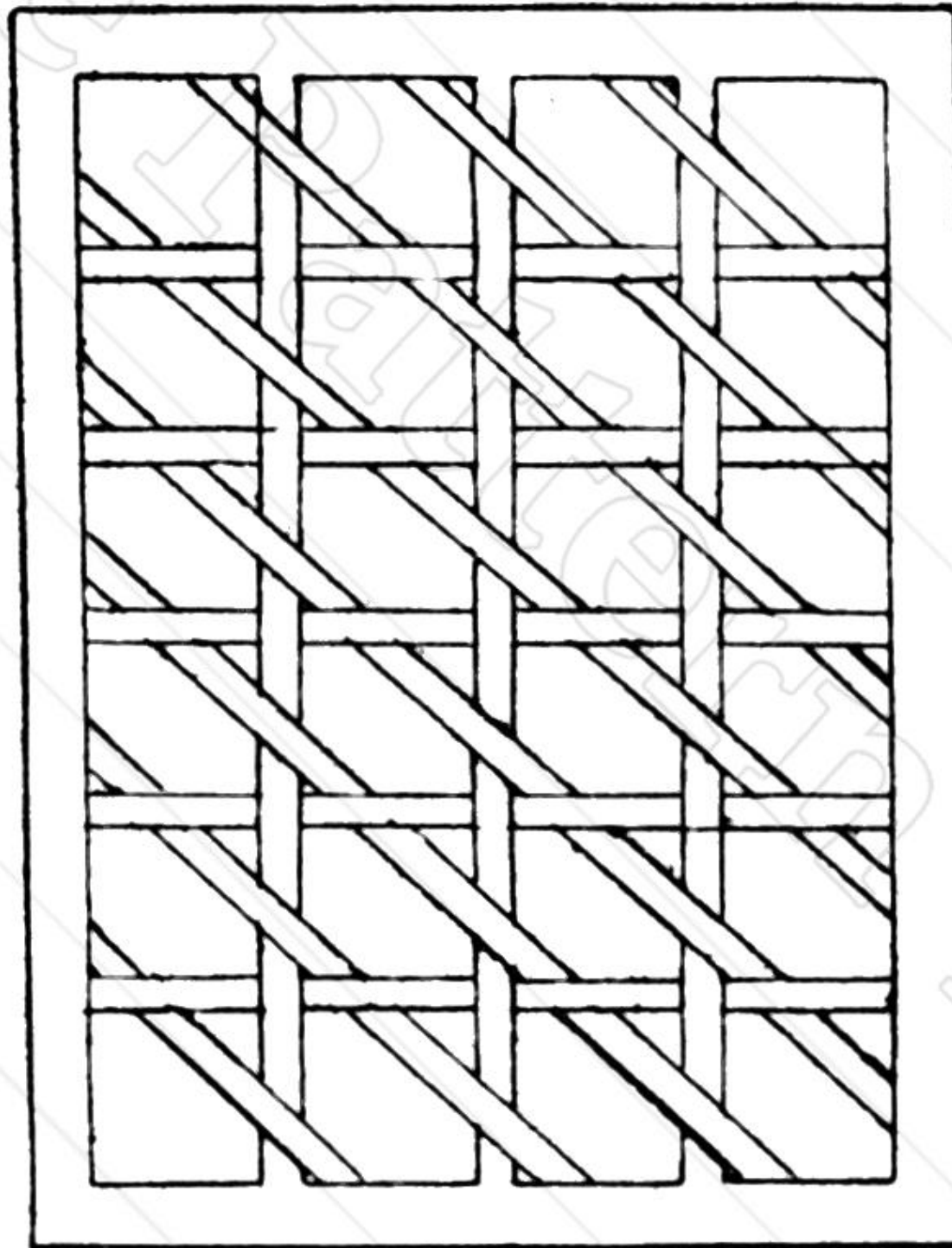

FIG. 36.

exercises have taught generally to "lift up" those that are down, the children will tell that the new strip will "lift up" the horizontals that are down, and pass over the verticals.

Use a strip of different colour (blue) and begin *under* the border at *bottom right-hand corner* and pass *over* first vertical and "lift up" the first horizontal. Continue over each vertical and under each horizontal till the strip reaches the other side. Begin at next space and continue till mat

is entirely crossed one way, as in Fig. 36. Cut strips and gum in position. It is easy to say "Lift up all the red strips and pass over the white ones."

Second Diagonal.—Turn mats the lengthway and the second diagonal will then follow the same rule as first, viz. "lift up" the horizontal strands. Use again a different colour (yellow), because it is so much easier to examine and give definite commands if the colours be different for each weaving. When the children thoroughly understand

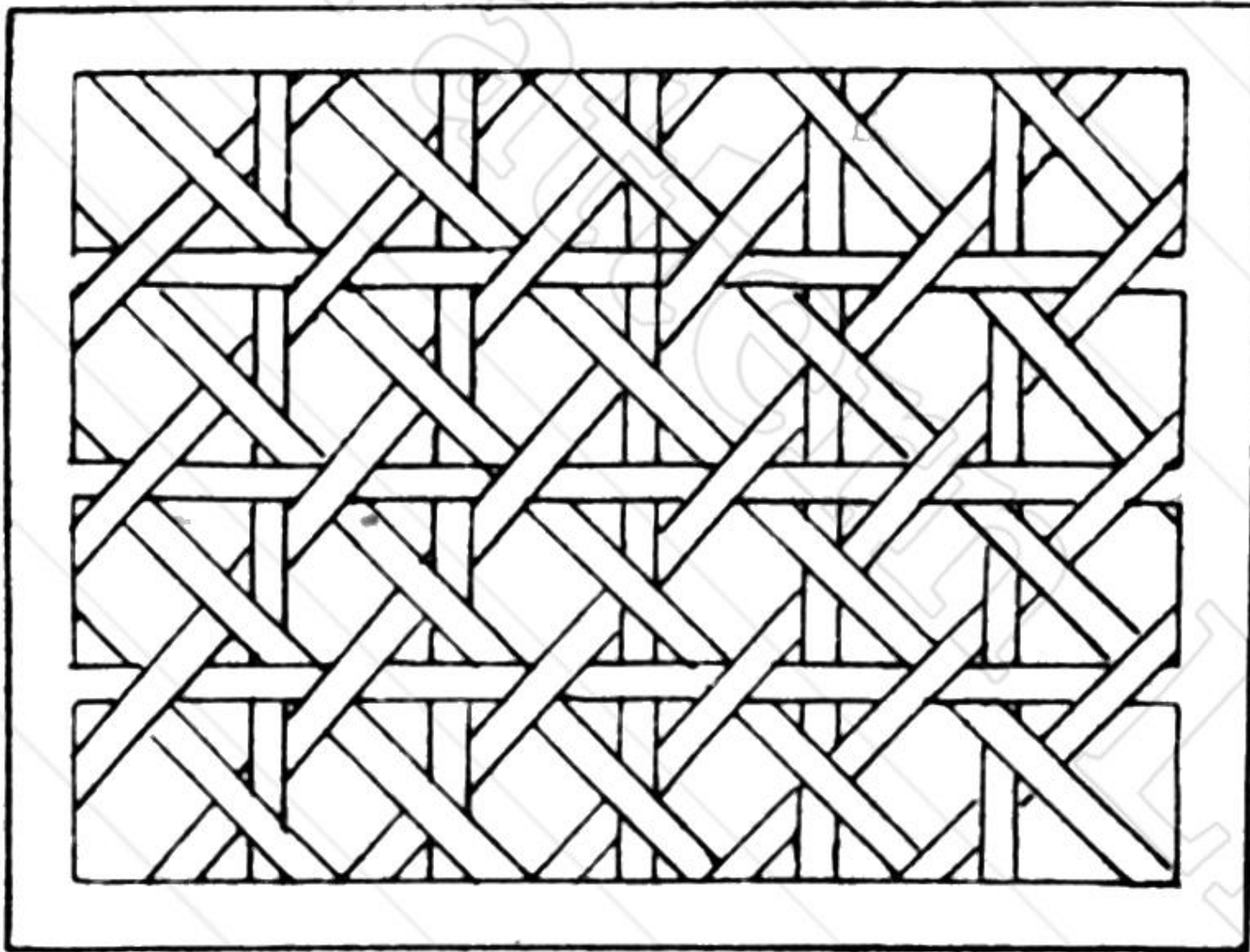

FIG. 37.

what to do, then the weaving may be of one or two colours, as desired, and afterwards lined with a contrasting shade. Two opposite diagonals must cross each other, *always with the mat strip between*, they must *never touch*; if they do, the weaving is wrong.

The diagonal strips will be of different lengths, and should be measured and cut as they are fixed in position.

Teacher should illustrate each point herself upon a large mat before the children.

Diagonal weaving is best worked on the right side of

DIAGONAL WEAVING

43

the mat, as the different coloured strips materially assist the accuracy of the work.

The mats may be utilised and made into pretty articles like the plain weaving mats. They look well lined with coloured tissue paper before mounting on cardboard.

Handkerchief Satchet.—The illustration is a very useful handkerchief satchet, made of four square mats. The mats

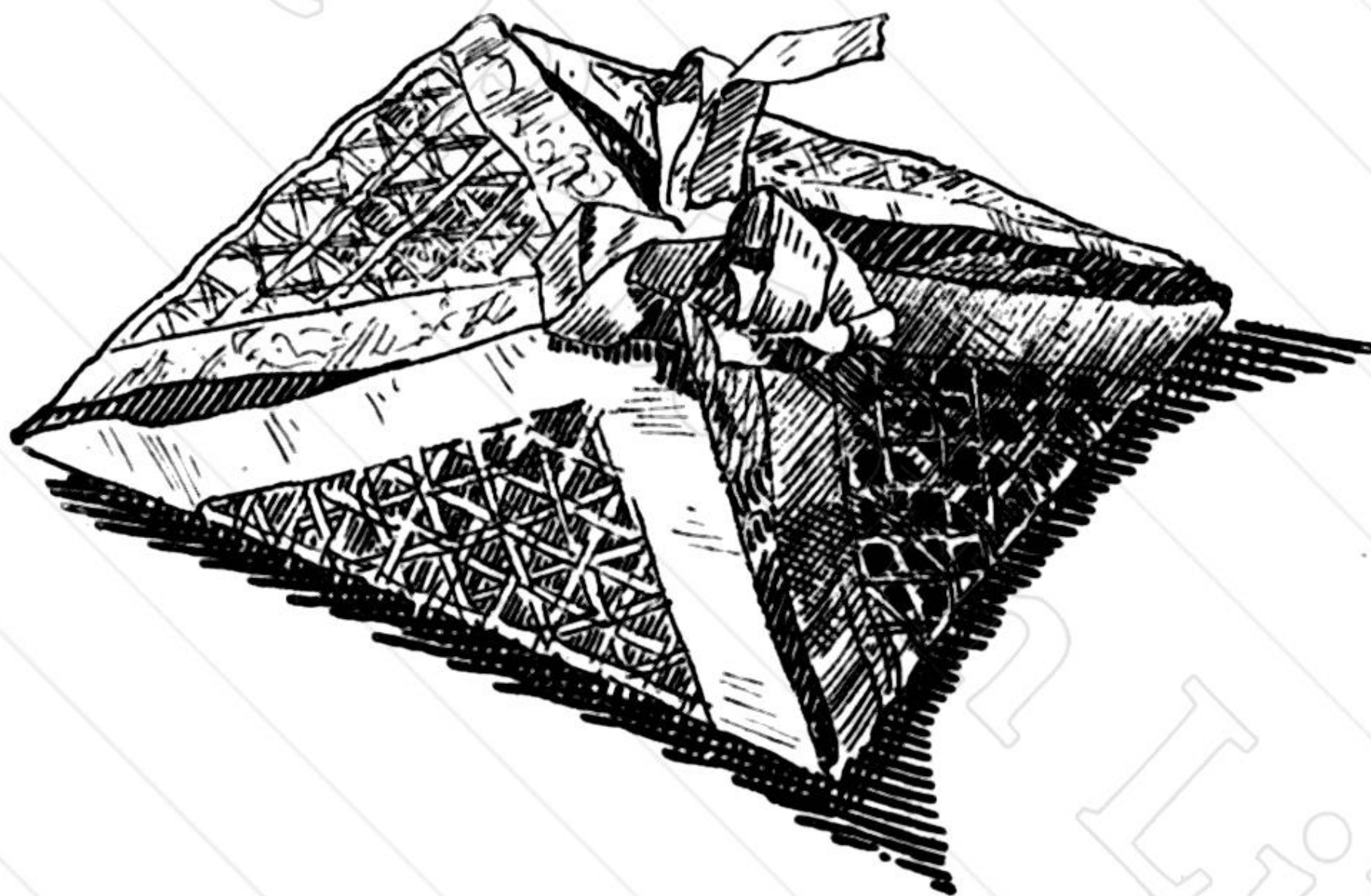

FIG. 38.—Handkerchief Satchet.

used are the “City taffeta mats,” sold by Charles and Dible. They are prettily traced in gold, and are issued in good art colours. Those used for this illustration were two peacock blue and two old gold mats. The four were pasted to a square of terra cotta sateen; each mat was creased diagonally to the centre whilst the paste was damp, and the points finished with bow and ends of ribbon. There are also some very durable morocco leather mats and a very dainty lace-bordered kind, useful for the same purpose.

FREE WEAVING

Description.—Free weaving, as the term implies, signifies weaving with loose strips only. There is no mat

as in ordinary weaving, but the free strips are so interlaced as to form mat and strips combined.

The occupation is suitable for children who possess a knowledge of weaving.

The advantages of this weaving are :—

1. Both sides of the work are alike, and therefore needs no lining or mounting.
2. Any sized piece of work, of any shape, may be made.
3. The work can be used in as many ways as ordinary mat-plaiting.
4. The work can be applied to ribbons, cloth, and other materials for producing useful articles.

Materials required.—

Long strips of paper of any width, and of two different colours. These may be folded and cut in brown and cartridge paper by the children, but it is preferable to buy the strips in packets ready prepared for this work.



FIG. 39.

They may be bought in four colours: cream, brown, pink, and gray, at 6d. per packet.

The cream and brown are thick, and the pink and gray thin in quality.

Strips of gold, silver, and other bright colours may be bought, also borders for finishing the work.

Method of Teaching.—Give each child two strips of cream paper about fourteen or sixteen inches long and half an inch wide. These form the loose mat.

Double the strips in half, and place vertically side by side upon the desk, thus:—Loop end *top* of first strip, and free ends top of second strip, as in Fig. 39, A.

As these vertical strips are troublesome for the children to keep in position until a little weaving has been done, it is advisable to fasten them with drawing pins to the desk or a mill-board. The latter is to be preferred, because the work could be kept flat and collected each week on the board until the piece required was finished.

The vertical strips must *always* be of the same colour, and different to the horizontal ones.

Distribute four or six brown strips about five or six inches long, and of *same* width as the vertical strips. Double in half, open the ends, and pass the *double* cream *inside*, then pass both ends of the brown through the loop of next cream strip, drawing the ends tightly through.

Children will readily learn that the *brown* and *cream* take it in turns to go *inside* and *outside* of each other (Fig. 39, B).

Take a second brown strip, double in half, and repeat the process from *left-hand* side, viz. outside first double cream, and inside second double cream. In passing *outside*, one end is on top of vertical double strip, and *one* is under. Fig. 40, C.—Continue weaving from the right and left

alternately, until the desired length is attained. The first exercise might be letter I, as children should not attempt anything requiring more than two vertical strips until the work is understood. Most of the straight-lined letters of the alphabet may be made in this way, and any width of strip can be used. The letters look well, mounted to form texts and mottoes.

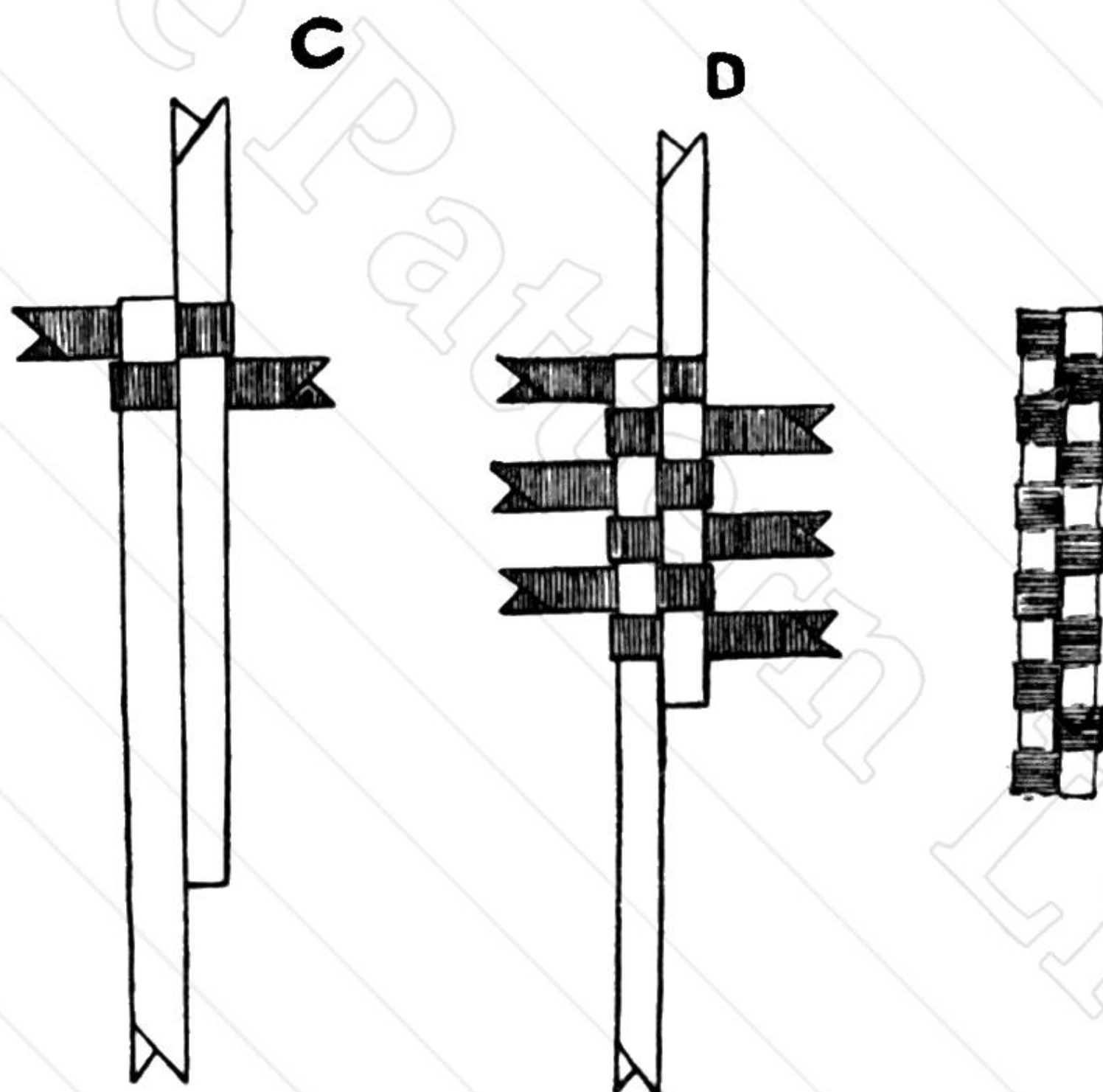

FIG. 40.

To Finish.—Remove the drawing pins and take hold of ends top and bottom of the vertical strips, and pull tightly until the loop ends lie close to the horizontal strips. Next pull every two horizontal strips right and left in the same way till the weaving is close and compact. The ends must be cut and turned under and pasted, or cut close to the weaving with a touch of gum to keep them in place. The work is easily joined by interweaving the ends on one side into the loops of the opposite side.

FREE WEAVING

To make letters L and T, and crosses and shapes requiring wider portions, the weaving strips introduced must be long enough for the wide part, and extend equally both

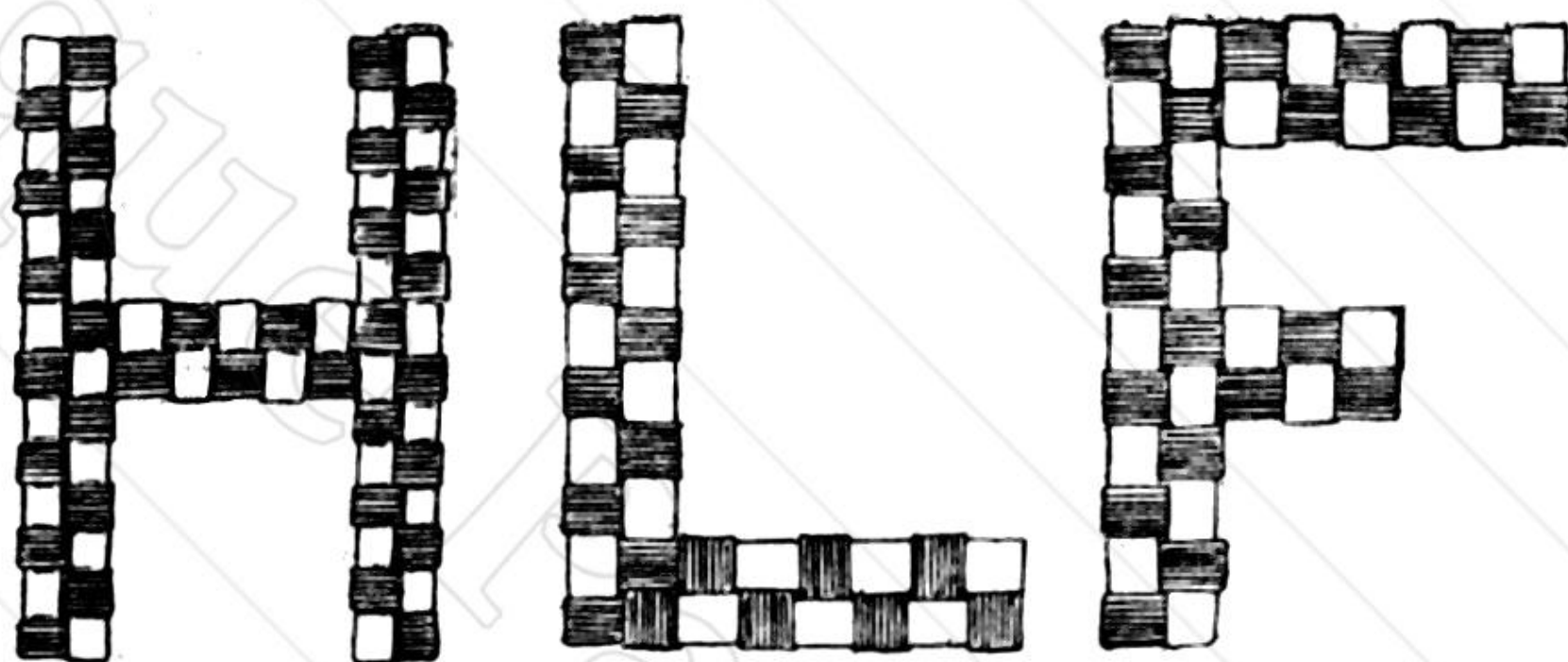

FIG. 41.

sides, as in T, or only one side, as in L. In both cases the vertical portion is woven first, but long horizontal strips introduced where the wide part of the letter will come.

Turn letter round so that the long strips thus inserted become vertical strips, and work them as such, getting the base of L and the arms of T in this way.

Shaped letters, such as O, S, Q, etc., are made by cutting

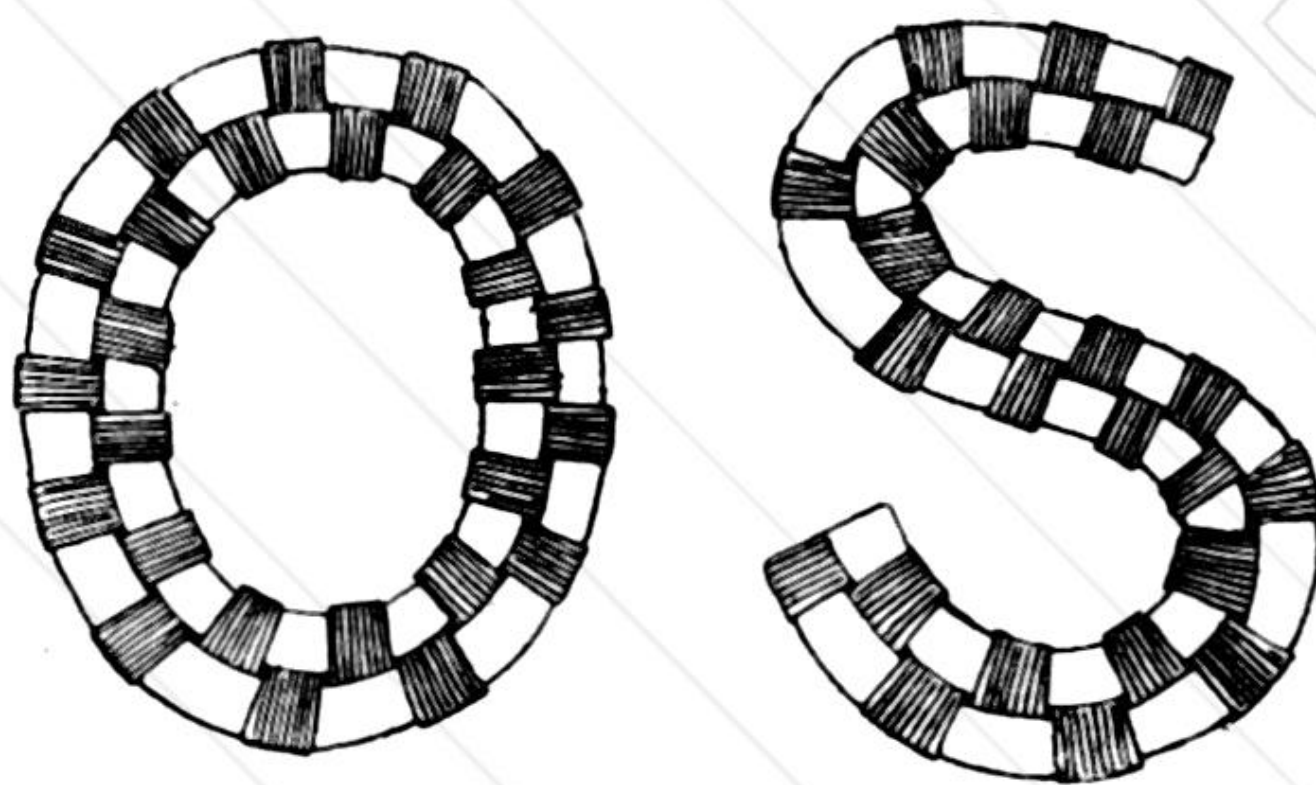

FIG. 42.

the letter out in duplicate, and using these doubled forms in the same way as two vertical strips. For example, to make letter O, cut two large ovals of exact size and width, and lay on desk on top of each other. Next cut two smaller

circles from the centres cut out of the large ones, because these two inner circles must fit *exactly* inside the two large ones.

There are now four circles, viz. a pair of large ones outside, and a pair of small inside.

Secure these in position with a drawing pin until a little weaving holds them together.

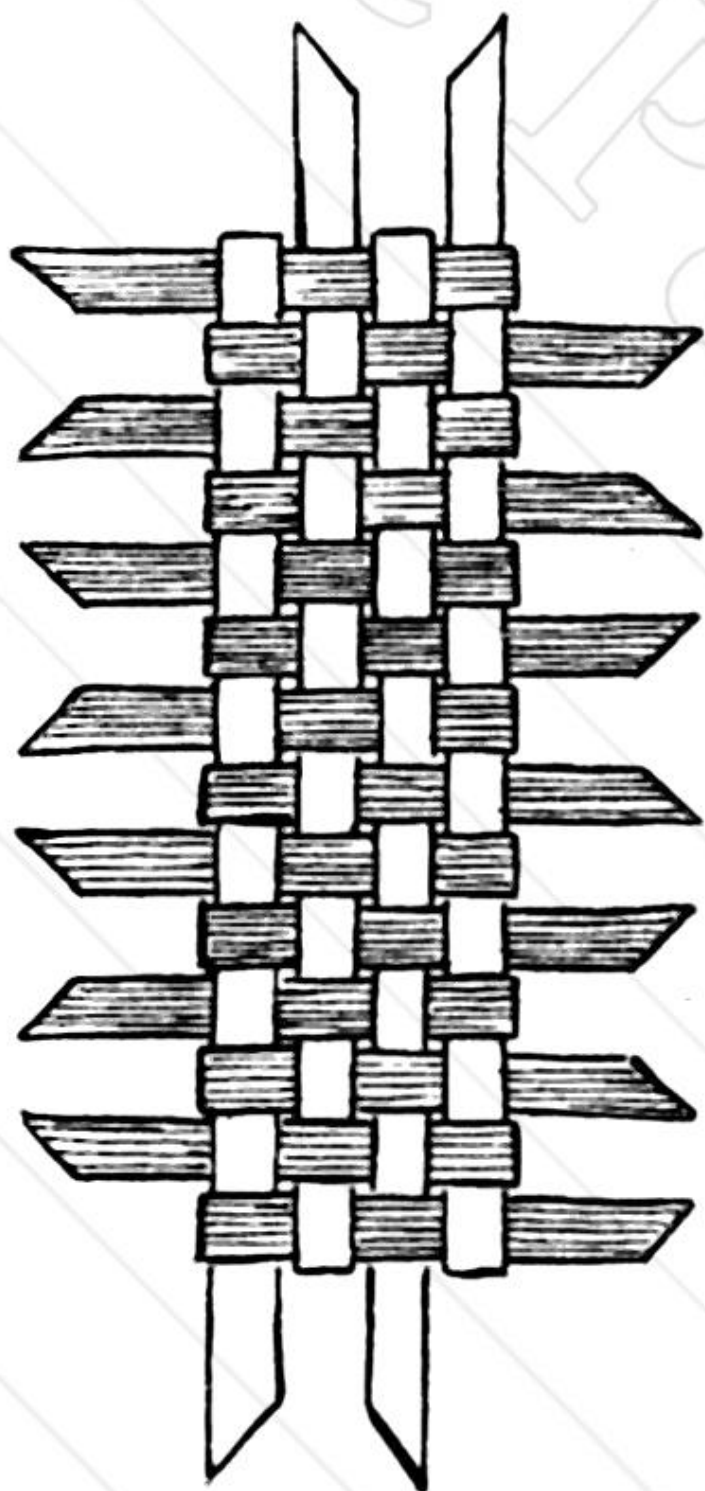

FIG. 43.

Take some short strips, and narrow them off to fit the inner circle, first the loop and next the free ends. Weave these strips in and out the double circles, just in the same manner as straight weaving.

These shapes are more difficult to manage, and not easily done by infants, but it is well to know how to make them should a word require their use.

Uses. — Square photo frames with cut-out centres are easily made, also mats, picture frames, wall pockets, handkerchief sachets, crosses, doll's furniture in outline, such as table, chair, stool, box, etc.

Small squares woven in strips of cloth, or dress material, and bound with red braid, make useful iron and kettle holders. Two coloured braids could be used instead. Strips of red and gray list woven in this way make admirable stays for children, and require no lining. A simple binding of braid is all that is necessary.

Hanging Bag.—This little bag is made of four strips of pink ribbon, 18 inches long, interwoven by sixteen strips of

FREE WEAVING

49

green the same length. Fold the strips in half, and arrange them in the following order: Loop end, free ends; loop ends, free ends, as in Fig. 43. Remember that the vertical strips are always of an even number, and correspond top and bottom in the number of loops and free ends. Begin as directed in illustrations A, B, C, D, weaving outside and inside the four vertical strips, beginning at the right side. Take another strip, and reverse the process, beginning on the left. If the work be not fastened, it can be *turned over* each time, from R to L, when the weaving will always be from the right-hand side, and each row identical in procedure.

Join the strip into circular form by interlacing the free pink

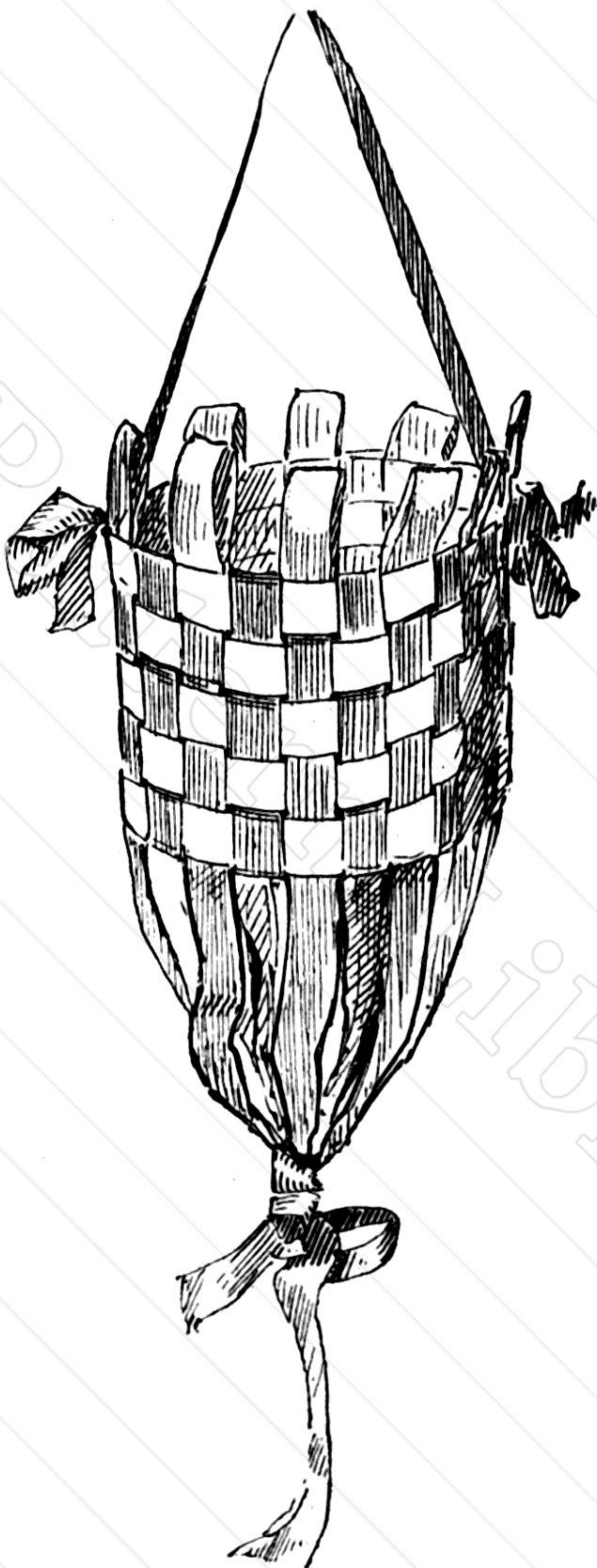

FIG. 44.—Hanging Bag.

E

ends into the weaving, and mount the work upon a small strip of cardboard covered in pink silk to retain the circular form. The lower portion is a bag of silk, over which the green ribbons fall and are gathered together, and finished with a bow of ribbon. Turn over the pink ends at top, and thread into the weaving to form a looped edge. Also add ribbon to each side to suspend the tidy.

Handkerchief Sachets.—The strips are all of equal length, and of two coloured ribbons 1 inch wide. Weave a square of 8 inches, and leave the ends of equal length on all four sides.



FIG. 45.—Handkerchief Sachet.

Take the ends of two adjoining sides and alternate them, one on the other, widening the space gradually from the corner. Fasten

with a few stitches, and ornament with bow of ribbon. Tie the two halves together with an end of each coloured ribbon, blue and yellow, or green and pink.

FANCY WEAVING

This is a very simple occupation, and combines exercises in paper-folding, cutting, and weaving. It is suitable for children who have had some practice in paper-folding and cutting. The occupation will be found not only attractive, but educationally good in training the “hand and eye” and in combining colours. Any width of strip may be cut, either broad or narrow, to suit the requirements of the article to be made,

The beauty of the work lies in the groundwork, which should be of a contrasting shade to show through the interlacings. Strips of tissue paper cut in this way are useful for decorating gilt frames as a preservation from fly-blows.

Materials required.—Foolscap, newspaper, cartridge, or tissue. Kindergarten scissors.

Method of Teaching.—For teaching purposes any used stationery is suitable, which must be first cut in strips about three or four inches wide. Distribute strip of paper and a pair of scissors to each child in class, and all must work simultaneously with the teacher to the following commands:—

1. Fold strips in half, lengthways.
2. Turn down the *double edges* about half an inch and crease sharply, the whole length of strip.
3. Raise the edges folded down, and hold both together in left hand, the centre fold being to the right.
4. Cut obliquely from *folded edge* across to crease. Begin about one inch from the top of folded edge and cut in a slanting line to *top* of crease.
5. Continue to cut a series of oblique cuts down the whole length of strip, making each cut $\frac{1}{4}$ inch in width.
6. Open papers.

Interlacing.—1. Turn papers with the angles pointing to the top.

2. Turn down every alternate angle as far as it will go, and crease the folds at sides horizontally.

3. Turn down angles 2, 4, 6, 8, 10, etc.

4. Pass the points of *upward* angles *over* and *under* the points of *downward* angles.

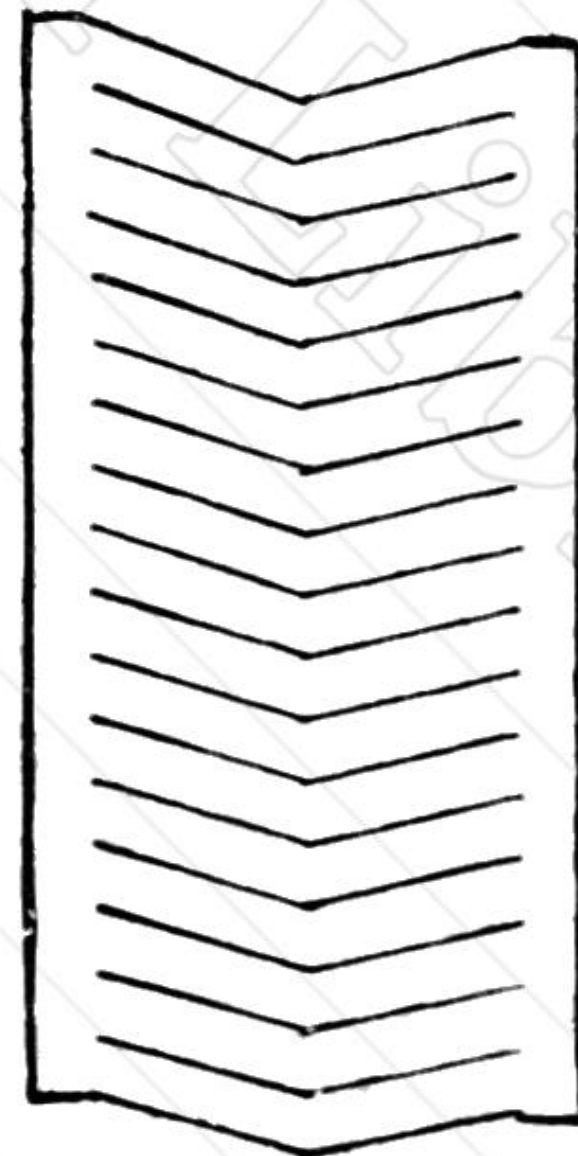

FIG. 46.—Open papers.

5. If desired, strips of narrow ribbon or paper may be

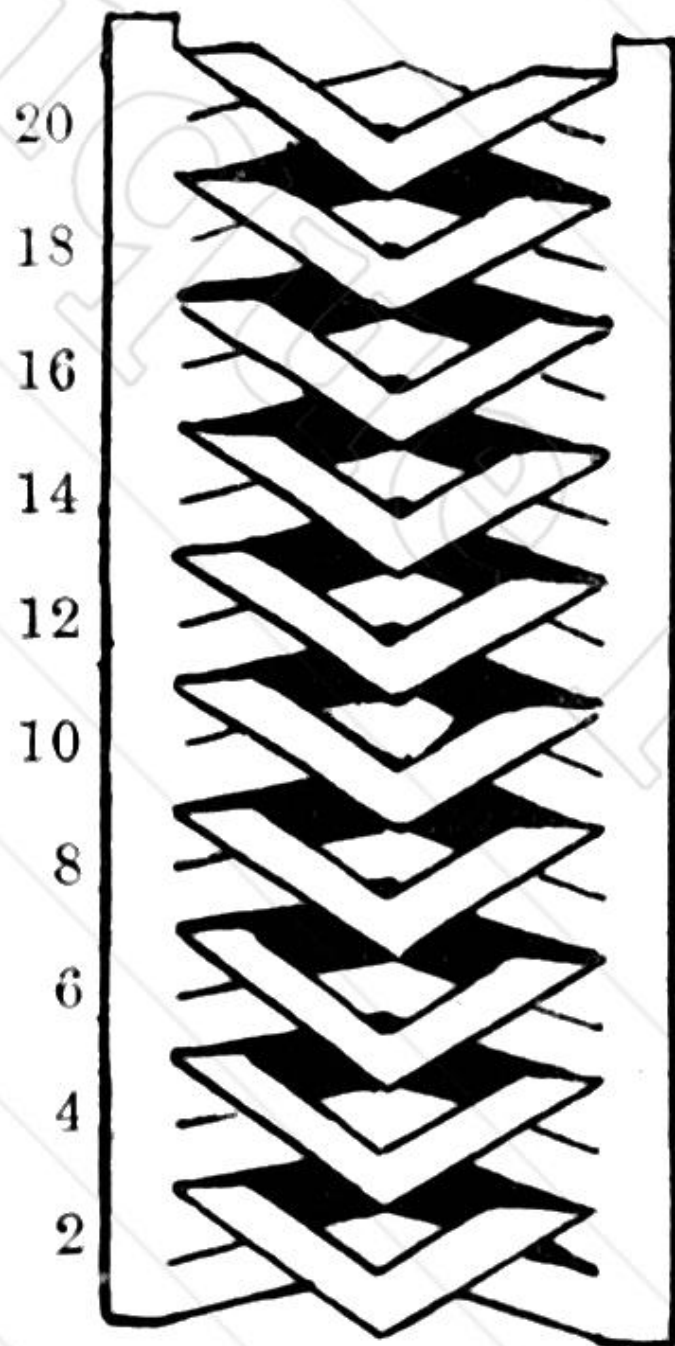

FIG. 47.—Angles.

interwoven in the open spaces, and add to the effect. Used in this way, the strips are pretty and useful as bookmarkers.

Care must be taken that the cuts are of equal width and length, otherwise the pattern will not be symmetrical. The wider the strip, and the

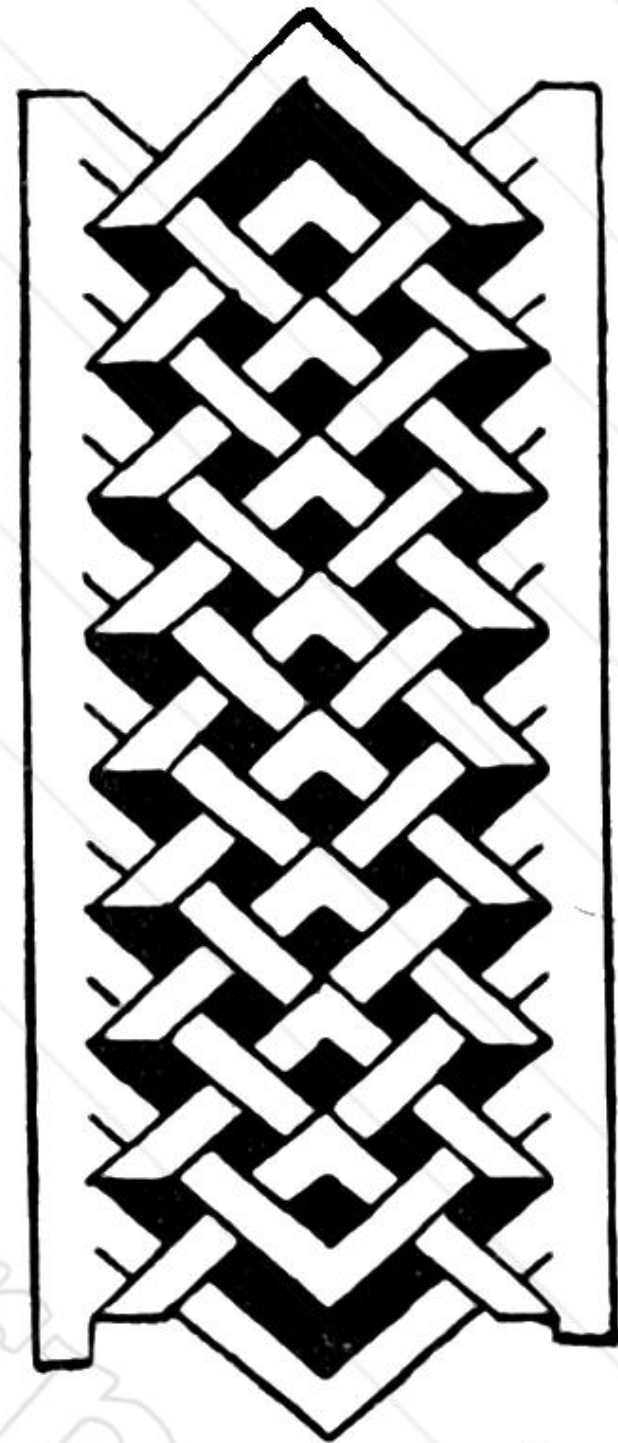

FIG. 48.—Interlaced.

more angular the cut, the greater will be the number of interlacings.

Newspaper Rack.

—The weaving portion is made of thin blue cardboard, folded and cut to the above directions.

The strips after being interlaced are mounted upon a stiff cardboard foundation of terra cotta cardboard. The sides

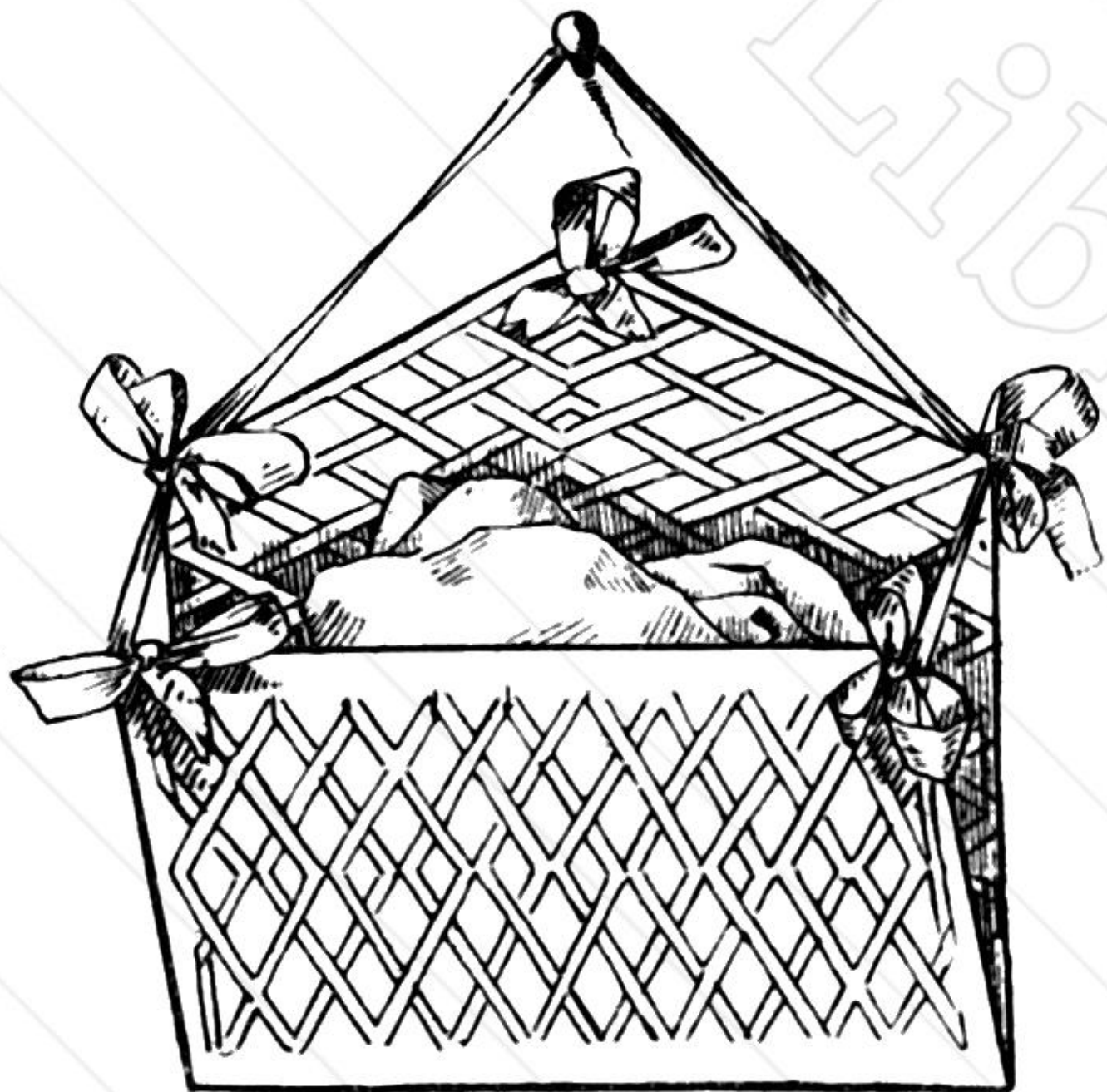

FIG. 49.—Newspaper Rack.

PAPER-PLAITING

53

are open, and attached to the back by loops of ribbon. Any shaped tidy may be fashioned and covered with this work in the same way as ordinary paper mats.

Spill stands are very suitable articles to make, because the *width* of the paper may be cut to the *height* of the stand, and only a short strip will be needed to go round.

PAPER-PLAITING

Children who have been taught the various kinds of weaving, as explained in preceding lessons, will readily take an intelligent interest in the following adaptations of the work, which might more strictly be termed "plaiting."

It is best to teach each exercise with strips of *different* colours, so that a definite command may be given for the weaving of each strip.

The paper used must be moderately stiff, and for preliminary work any used foolscap or drawing paper will do for the purpose. The children might learn (1) to cut strips of paper about two inches wide; (2) fold in half; (3) open, turn the edges to centre crease; (4) fold edges inside, thus giving strips $\frac{1}{2}$ inch wide with straight folded edges, which are necessary for the evenness of the work.

For examination work, the coloured strips used for free weaving, and sold in packets at 6d. per packet, are best.

Materials required.—Long strips of paper of same width, and three or more drawing pins, and a mill-board, if possible.

Method for "Plait of Three."—Supply each child with three coloured strips, three drawing pins, and a mill-board. If the latter cannot be had, the desk must be used. Place the strips vertically side by side, and fix in position with

drawing pins. Write pattern on blackboard thus—"Outside strip over the centre one, first from the right hand, and then from the left. Crease the fold at side straight and even." Before writing the above, the teacher should plait the pattern on a large scale before the children, and let them describe what she does, and, when understood, write in words the pattern on blackboard. The children then to work *with* the teacher and repeat the pattern aloud for the first few exercises. They will soon perceive that the strips resolve themselves into two oblique on the right, then two oblique on the left. The plait is the common plait of three, creasing the sides as each strip is turned over.

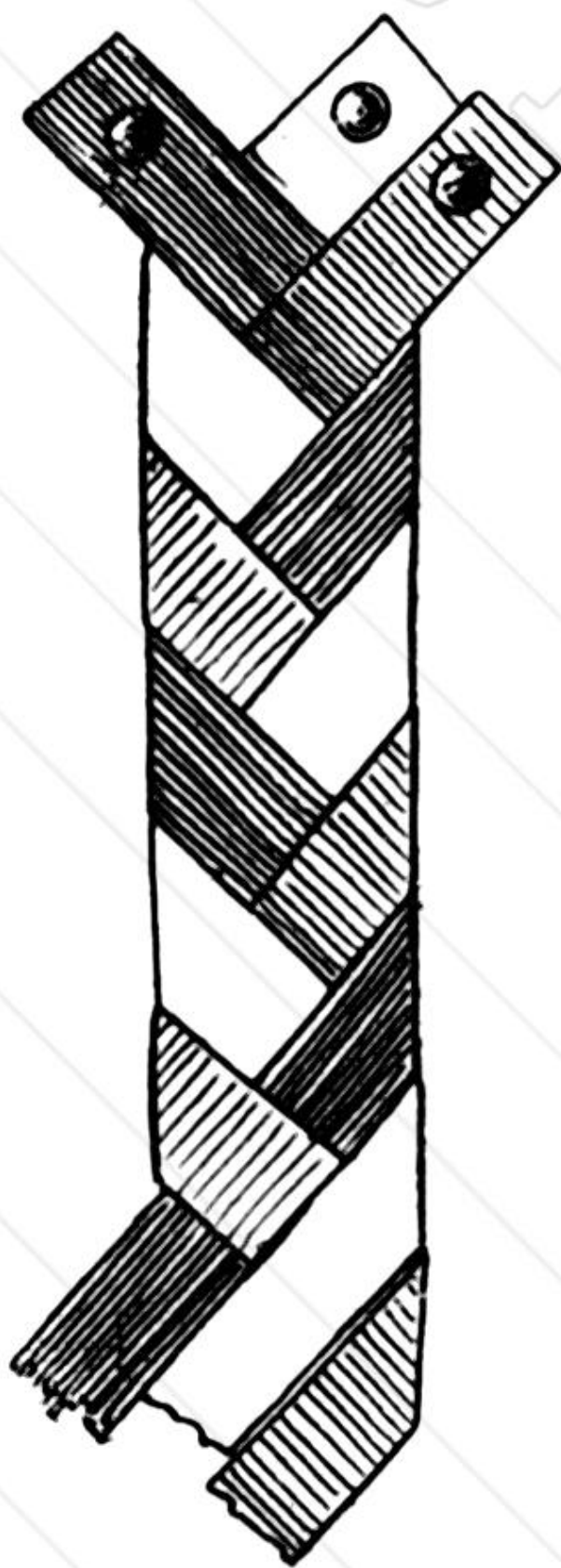

FIG. 50.

It is very pretty woven in different colours, and can be sewn together to form tidies, mats, bags, picture frames, etc.

Plait of Four.—Pattern "under one and over two," working first from right hand, then from left. The edges are mitred, or made of two angles of 45° produced by two strips folded back upon each other. This part is the only difficulty of the pattern, and should be practised with two strips several times

before attempting the plait. Give each child four strips of different colours, 1, 2, 3, 4, or four strips of two colours; 1 and 3 must be alike, and 2 and 4 alike.

1. Take strips 1 and 2; place No. 1 across No. 2 obliquely, as in Fig. 51, and crease it back upon No. 2. Then crease No. 2 back in same manner upon No. 1. This

PAPER-PLAITING

55

is the vandyke edge, which is shown on each side. Practise this vandyke fold with two strips until thoroughly understood. Children crease and fold in their hands.

2. When step No. 1 is known, introduce strips 3 and 4, and fasten the four strips to desk or mill-board with two drawing pins. Arrange the two strips 3 and 4 that they

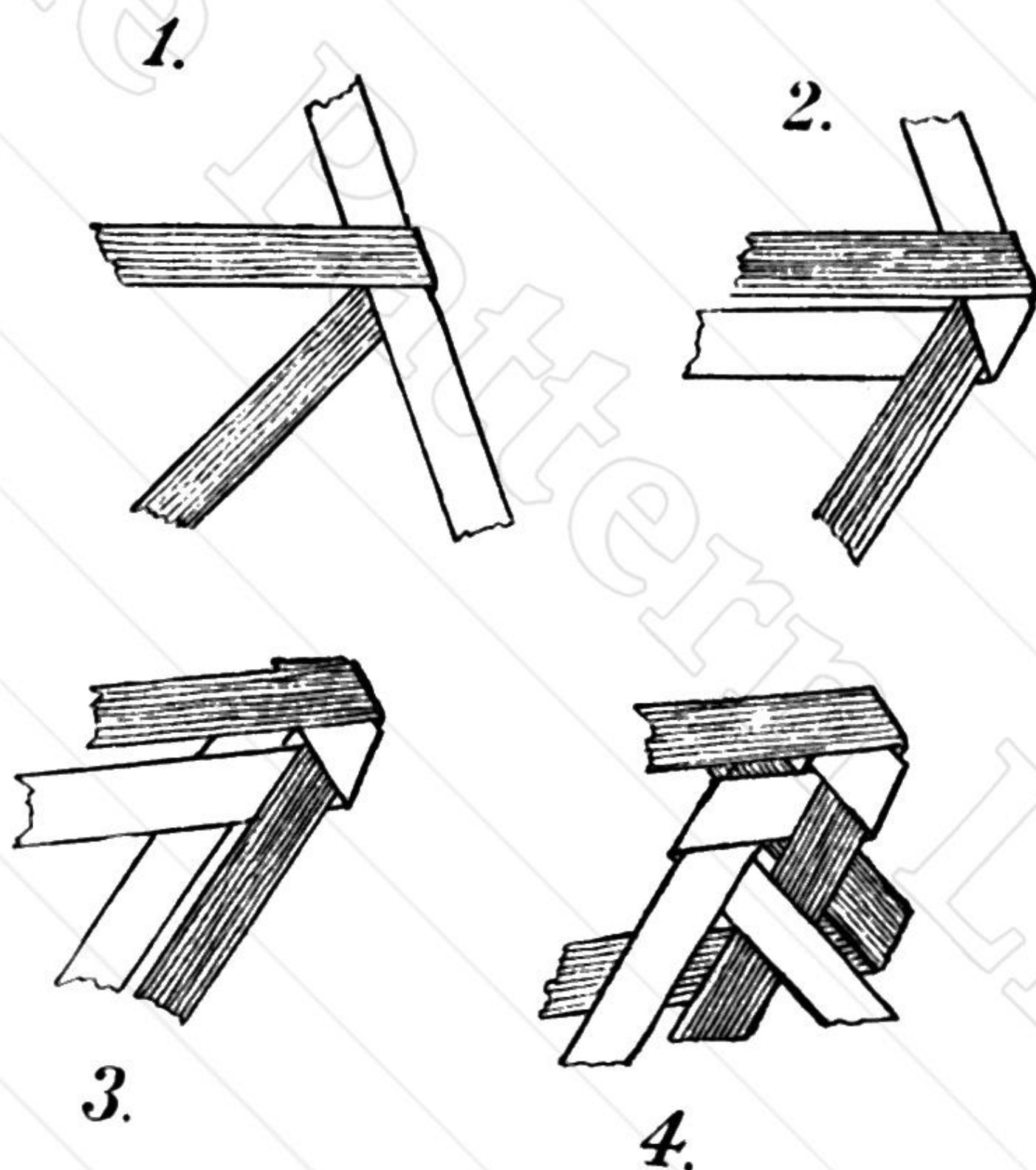

FIG. 51.

run obliquely right and left; then fix on strips 1 and 2 with drawing pins.

It will be noticed that the two strips, which the horizontal strip crosses each time, are two crossed strips, running obliquely right and left. The pattern is very simple when the vandyke edge is known. It resolves itself into—*Under one and vandyke—pass over two straight across to other side—under one and vandyke—pass back over two.*

OXFORD PICTURE FRAME

This plait when made in brown paper, or cream and brown, will be useful to transform into Oxford frames, in which to exhibit other specimens of the children's Kindergarten work.

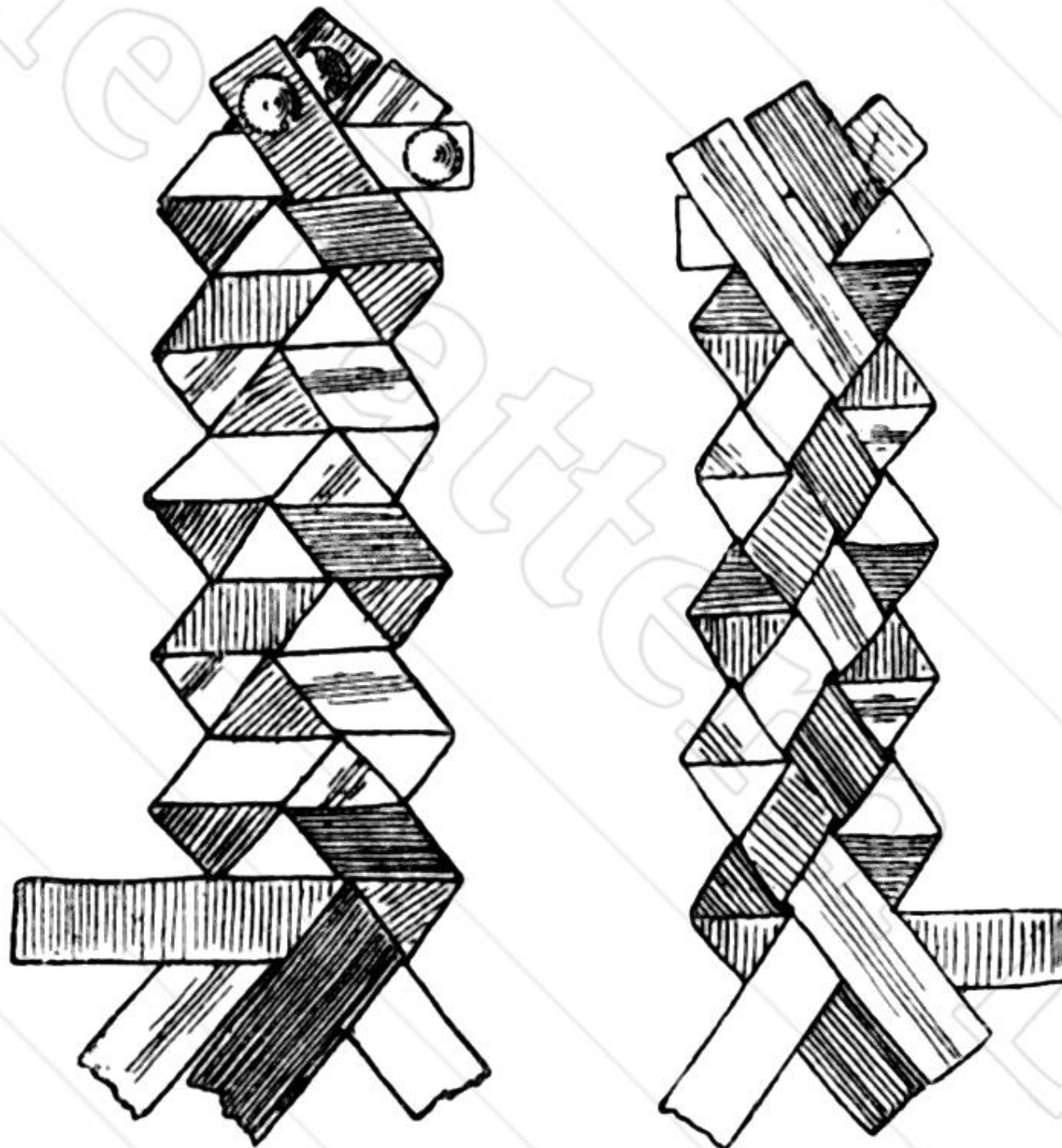

Working side.

FIG. 52.

Right side.

Cut four strips of cardboard, and cross the corners at right angles, leaving 2 inches extending each way. Secure the corners, and make frame complete. Fasten on strips of the plait, and let the vandyke points extend on either side beyond the cardboard foundation. Tie ribbons diagonally across the corners, and finish with a bow of ribbon for suspending the frame.

NEWSPAPER BAG

The columns of a newspaper are suitable for this plait. Let the children cut up the columns, fold column in half,

turn edges to centre, and fold again, turning edges inside. Use the strips for plaiting as described. Newspaper bags for fish or light articles may be made of these strips. When sufficient plaits have been produced by the class, make a Holland or calico case, and sew the strips round the bag horizontally, letting each successive strip overlap the last until the calico case is covered. Sew on two wider

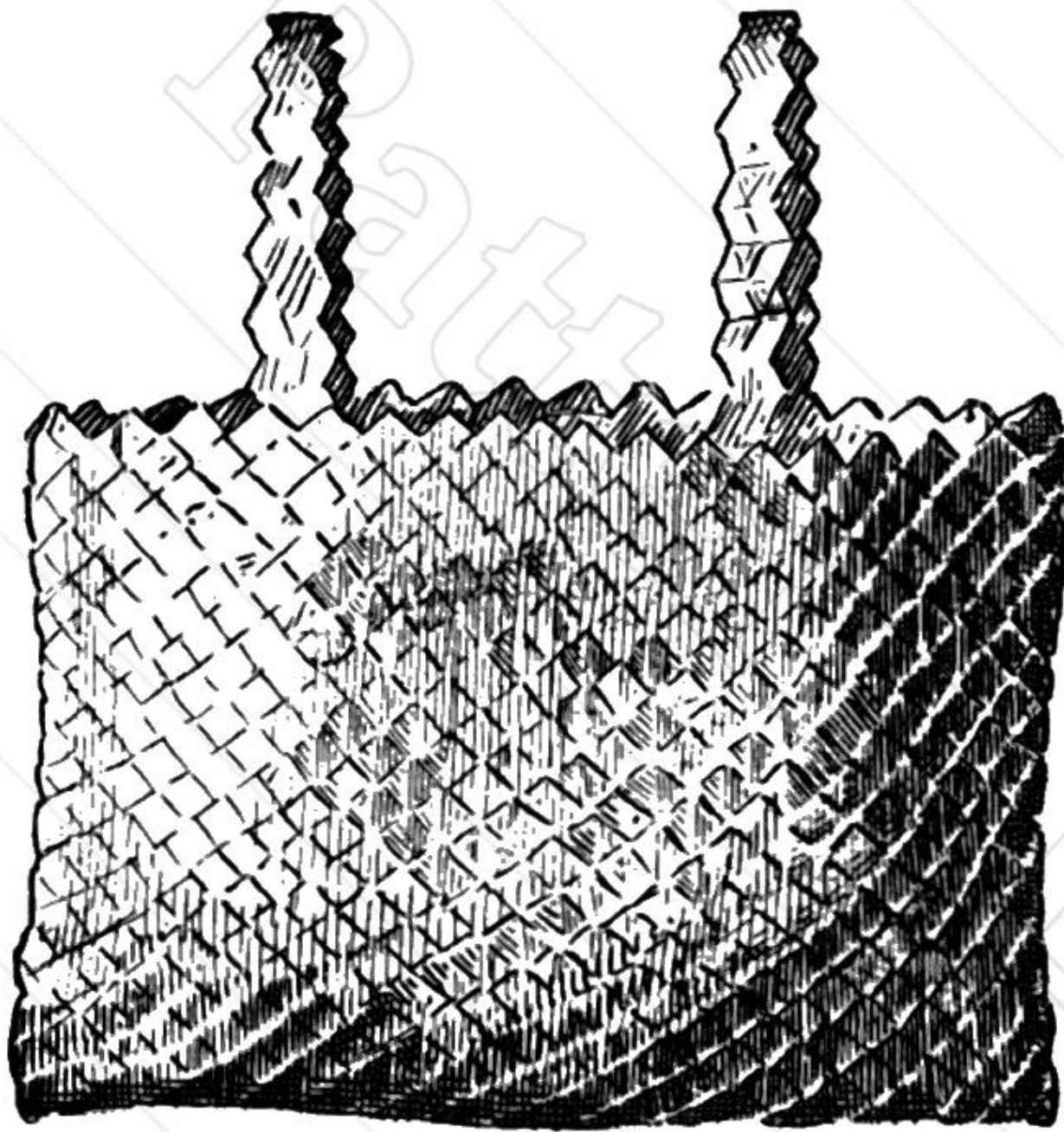

FIG. 53.—Newspaper Bag.

strips, fastened to a strip of Holland, for the handles, and the bag is ready for use. This bag, when finished, has the appearance of gray silk, and if lined with coloured silk to hide the calico foundation, might be used for fancy work or other purposes.

A child who becomes proficient in paper-plaiting may easily be taught straw-plaiting. The directions given being applicable to either.

PAPER-FOLDING AND WEAVING

LAMP MAT

This is a very handsome and useful mat for the centre

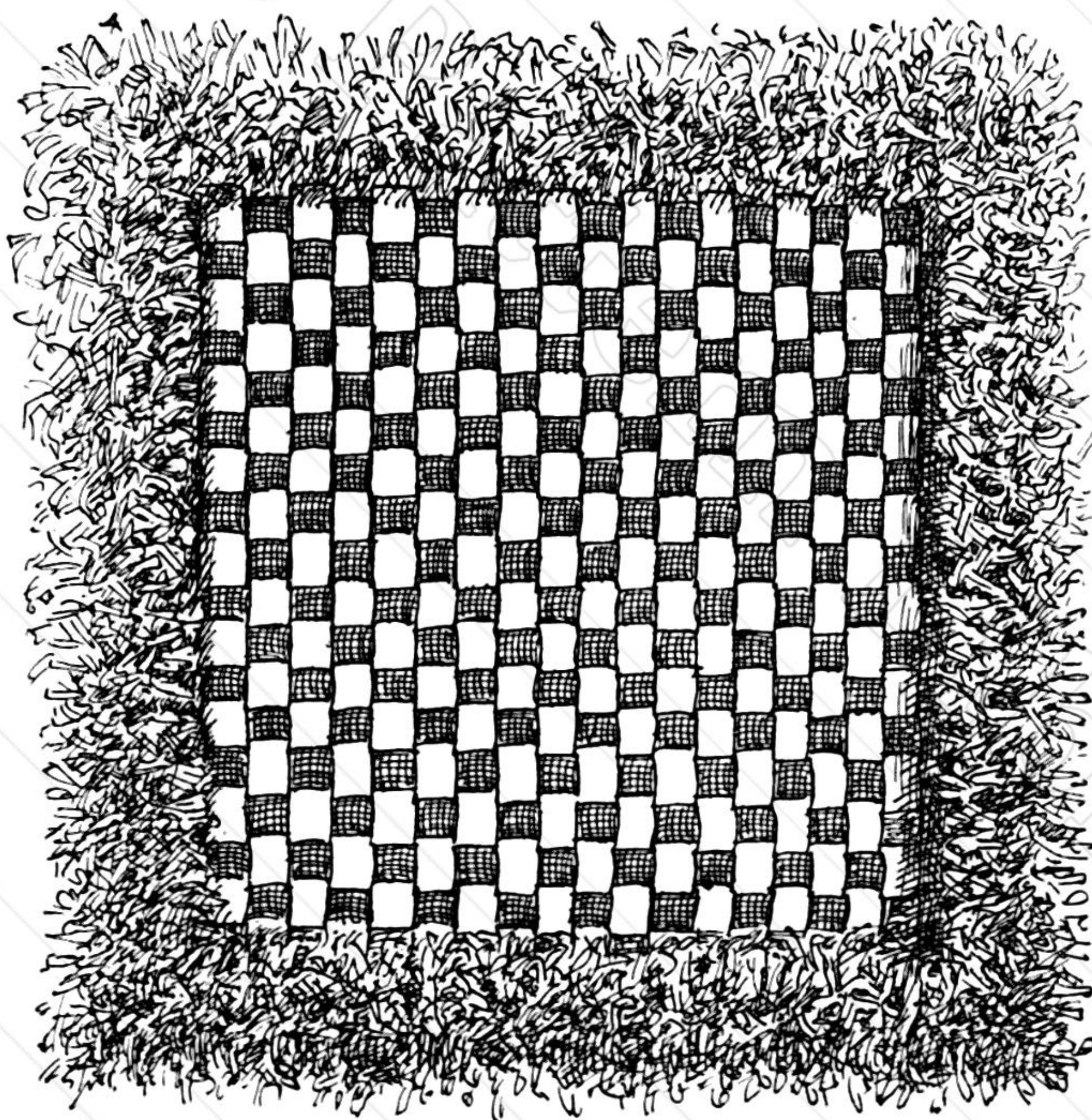

FIG. 54.—Lamp Mat.

of a table, and is made of folded carton paper, a tinted kind of cream laid sold in large sheets.

Materials required.—Give to each child a strip of paper $2\frac{1}{2}$ inches wide and 12 inches long. A pair of paper scissors, with rounded points and two paper clips, as described in Straw Weaving.

Preparation.—Before allowing the children to start cutting the carton paper, it is best to give them a little practice in cutting and folding strips of newspaper. Therefore, for this purpose, cut a number of newspapers into $\frac{1}{4}$ sheets and distribute one piece to each child. Let all the class cut off the border close to the print and leave only the columns intact. Show what is meant by a column and let class cut up the first line of division. The scissors must be held firmly in the right hand, with the thumb in one bow, and the second and third fingers in the other. The first finger must go under the shank to guide the points. The scissors' hand must be kept steady when cutting, and long, bold strokes should be made, otherwise the paper edges will present a very jagged appearance. Teacher to illustrate before class.

The strips are next folded simultaneously with the teacher as follows :—

- (1) Show strips holding short ends in either hand.
- (2) Lay lengthways on the desk.
- (3) Fold in half, lengthways, and make a centre crease.
- (4) Open papers and fold edges to centre crease.
- (5) Fold together the edges inside.

Do not pass careless folding. Let the children open and smooth their papers and crease again till the work is accurate. The strips should be quite even, rather more than half an inch wide, and both sides alike. Each child should keep its own folded strips until there are sufficient for a mat.

Weaving.—Give each child two paper clips, and let each

one interlace the folded strips into the two clips at once, one over and one under. When the clips are full, gradually separate them, drawing them to the top and bottom (see Fig. 111 "Straw plait clip").

This stage represents the mat, and the strips should be of one colour. A similar number of horizontal strips of a contrasting colour are now woven across until a 12-inch square of even weaving is produced. Care should be taken that the strips are placed the same way, *i.e.* with the double edges all running right or left. The mat in illustration is made up of terra cotta and pale yellow carton paper. Both sides of the weaving should be equally good, and the under side untouched by the hands should be used for the right side.

Mounting.—Cut a 14-inch square of stout cardboard and paste square of weaving exactly in the centre, which will leave a margin of cardboard 1 inch all round. Place a heavy weight upon the top and leave to flatten and dry.

Fringe.—If a narrow fringe be required the same strips will do, but for a handsome fringe the strips need to be cut 4 inches wide. Take two strips, one of each colour, and place together and fold as before. Turn down a narrow hem on the single fold side and make a crease. Lift up the hem and cut the double folds very finely as far as the crease. Rub with the hand and crumple. These strips of fringe are 12 inches long, and the cardboard foundation 14 inches. Take one strip at a time and gum to the edge of cardboard all round, leaving one square inch at each corner. These are better filled in last. Continue to gum strips round and round till the weaving is reached and the edges covered. The fringe should stand up handsomely, and the cuts well separated to show the two colours. When the border is complete, take a strip, fold it many times and fix in each corner, to give a full and finished appearance.

TOILET TIDY

Materials required.—(1) Tissue or carton paper (two colours).

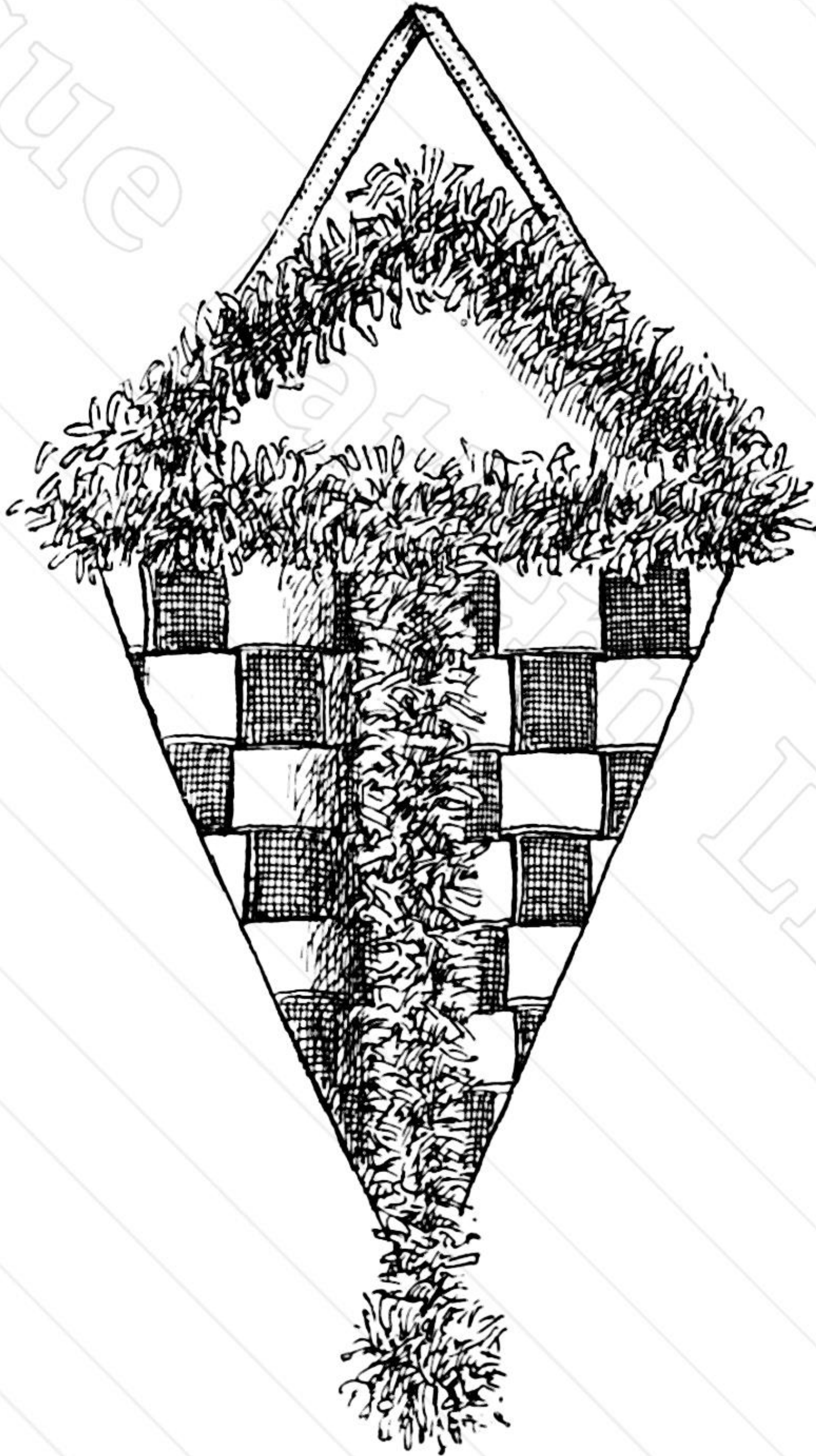

FIG. 55.—Toilet Tidy.

(2) Paper scissors with round points.

(3) Two paper clips.

Method.—Cut paper in strips and fold as directed in previous lesson. The strips may be wide or narrow, or both, as desired.

These squares of weaving may be utilised for pockets, tidies, etc. If the carton paper be used, it would be stiff and need no mounting, but the tissue will require a firm foundation. The pocket in illustration is made from an exact square of weaving, of 12 inches. Two adjoining sides of the square are sewn together, and then covered

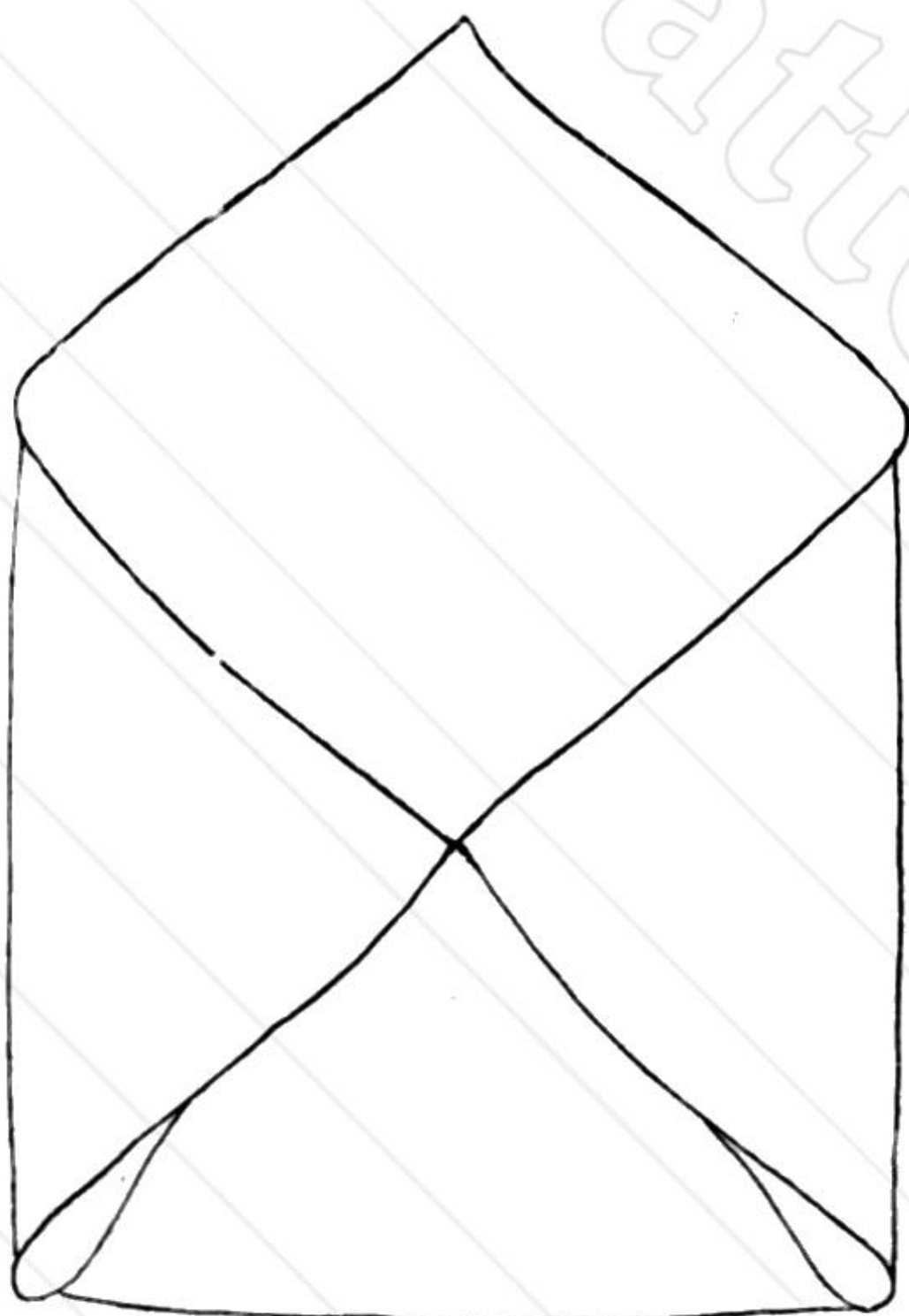

FIG. 56.

with a strip of fringe, gummed on either side, and the point finished with a cut tassel. Two strips of fringe are sewn round the top, on the outside, and another strip is gummed round the inside to hide the stitches. A loop of coloured ribbon is attached to the sides to suspend the pocket. These pockets should be made in pairs, and are then suitable to hang either side of the toilet glass, as hair tidies.

Square envelope pocket is another good shape to make from an exact square.

Any fancy shape may be made by mounting the weaving and cutting to shape. Then bind with ribbon and ornament with fringe.

WEAVING IN RIBBON

The articles illustrated show simple mat weaving with narrow ribbon.

The ribbon used must have a plain woven edge. The

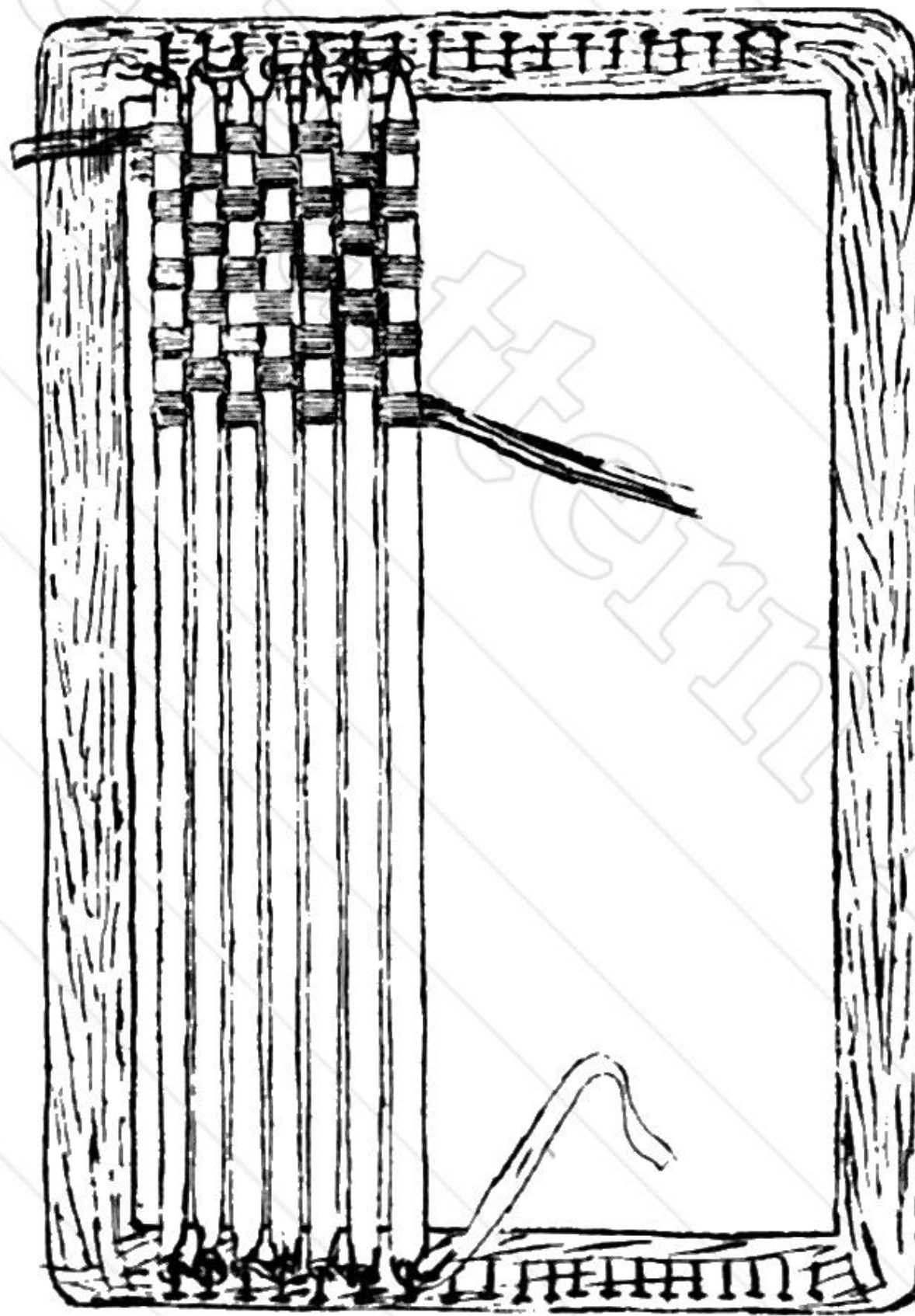

FIG. 57.

best for the purpose is plain sarcenet and satin ribbon at 10½d. per dozen yards, which can be procured in all colours.

A wooden frame is needed for straining the work. The ordinary slate frame answers the purpose for making small pieces of work, and if larger be necessary, a rough frame can easily be made from cardboard or the long sides of two

slates. Pegs or nails are inserted top and bottom of the slate, leaving a distance between each equal to the width of the ribbon.

Tie the ribbon round first peg and proceed across the slate to opposite peg. Pass across and round the next and so continue till the slate is full; see that the ribbon lies flat and close and vertical. Finish again by tying the end round last nail. This stage represents the tight mat. The cross weaving is done in another colour, and the ribbon is cut in lengths and woven with the ordinary plaiting needle. Each strip is placed quite flat and close to the last. Any pattern may be woven. When a piece is plaited of the size required, the teacher should see that it is accurate, and with needle and cotton tack round the outer edges before removing the work from the frame. To do this, cut

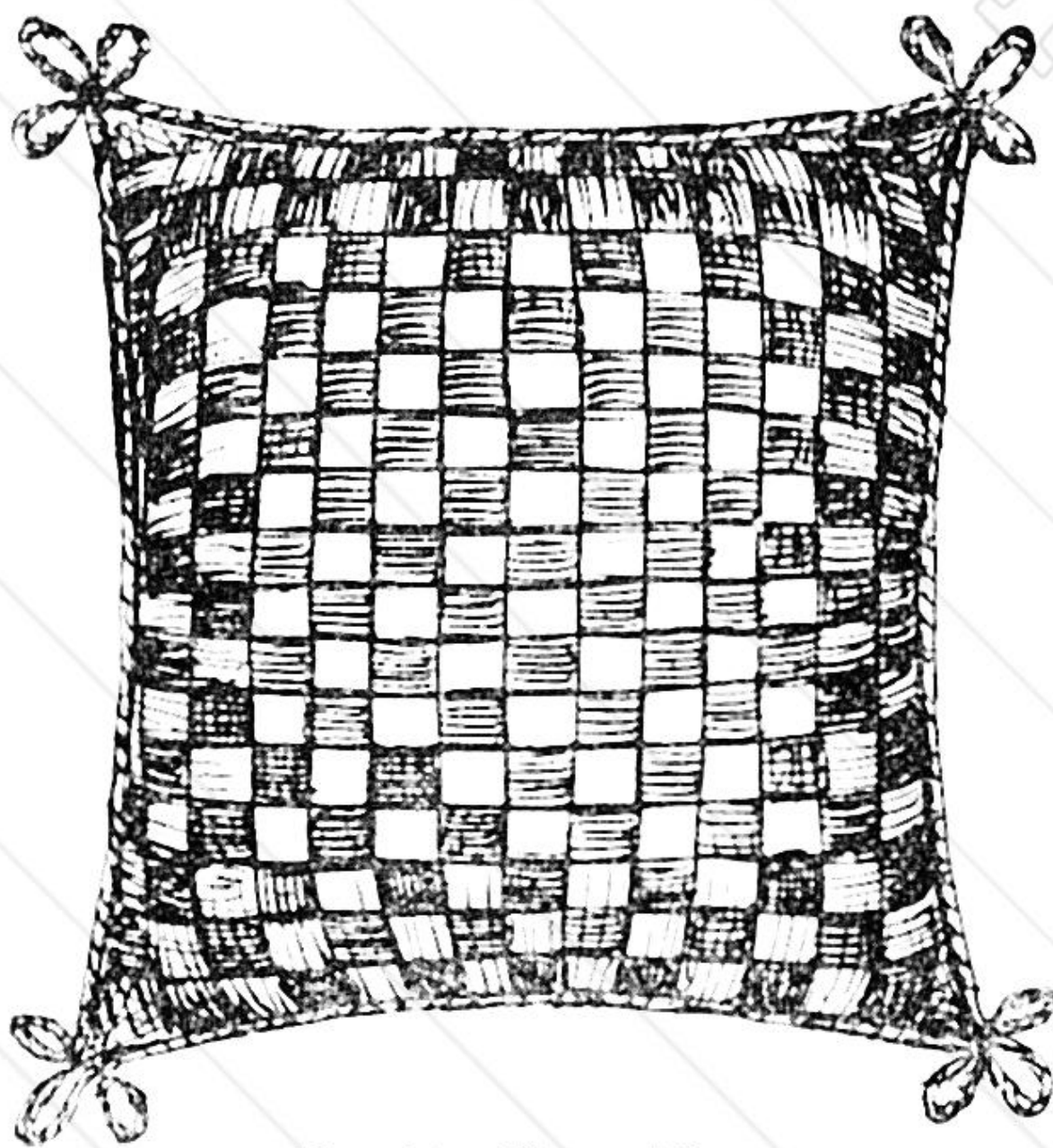

FIG. 58.—Pin-cushion.

the loop ends on the pegs, and lift the whole off the frame.

The piece of weaving may then be put to one of the following uses:—

1. *Pin-cushion.*—

Weave a piece of work upon ordinary slate frame 6 inches square, according to the directions given. Make also a calico case of the same size, let

children sew the edges and fill with bran or frayings. The outer case of cushion is made of silk, sateen, or velveteen for the under side, and the plaited top for the upper side.

Turn down the cut edges to the weaving and sew the plaited top to the square for under side. Let the children sew this case on the wrong side, holding the woven side towards them. Use silk or twist of same shade; when finished, turn case, press open seams, and slip cushion inside and sew up. Pull corners well out and shape the cushion. Finish the join with a narrow silk cord of same

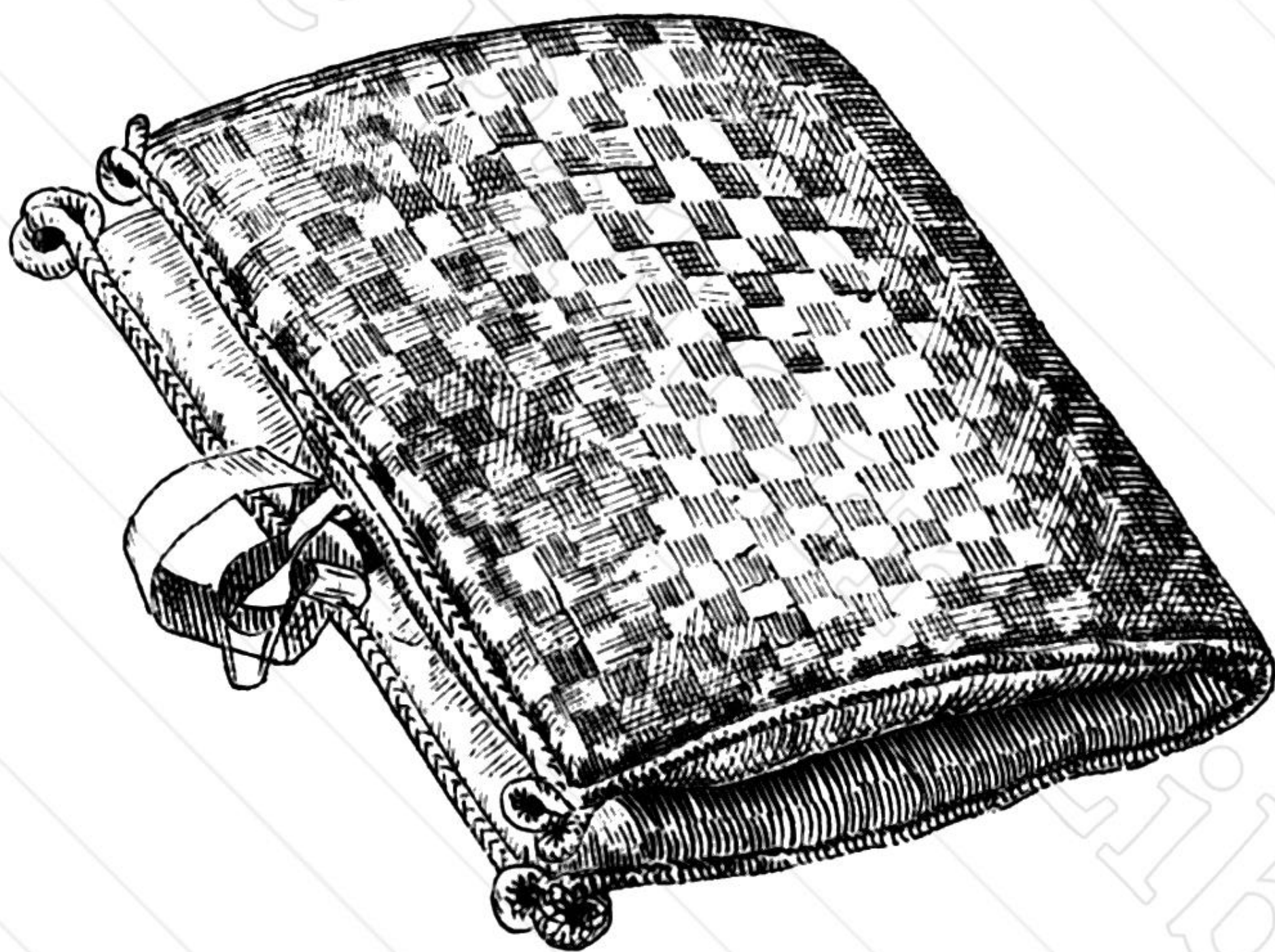

FIG. 59.—Handkerchief Sachet.

colour as ribbon. This must be sewn on by the teacher. The colours used in this cushion are white and yellow, with yellow cord. The corners may be ornamented with lace if desired.

2. *Handkerchief Sachet*.—Weave an oblong piece, 6 × 10 inches, in terra cotta and pale blue ribbons, and turn down the edges as directed for cushion. For the lining cut a strip of pale blue sateen, 8 × 12 inches, and a strip of wadding, and quilt together to the size of 6 × 10 inches. The quilting

F

may be run by hand in sewing silk or by machine. The quilted satin sold by the yard is very nice for making up this work. Tack the plaited piece to it, wrong side, and let the child sew round three sides. Turn the work and fasten up the open side. Finish round the edge with a silk cord, and fasten together with bow and ends of ribbon.

A large square of 10 or 12 inches will make a handkerchief sachet, with the four points folded to the centre and fastened with ribbon. This shape is also nice quilted, and if filled with sachet-powdered scent between the lining makes a very pretty and desirable present, and an article appreciated by the parents. The teacher's time is better spent in finishing off a really useful article than in making up paper weaving articles which are unsaleable and take as much time to complete.

FOLDED SATIN SOFA CUSHION

Materials required.—(1) $\frac{1}{4}$ yard of pale green satin at 1s. 0 $\frac{1}{2}$ d. a yard.

(2) $\frac{1}{4}$ yard of old gold satin at 1s. 0 $\frac{1}{2}$ d. a yard.

(3) 1 $\frac{1}{2}$ yards of silk cord at 1d. a yard.

(4) A strip of unbleached calico for case.

(5) Bran or wool for stuffing.

(6) Reel of green silk.

Method.—Children who have already had paper-folding and cutting, and are proficient in making mats and tidies, might be allowed to start upon this pretty and useful article, which is inexpensive and yet very simply made. The satin must be cut in strips the selvedge way, 2 inches wide and $\frac{1}{4}$ yard long. The satin will fold as easily as paper, if cut the way of the selvedge. Each strip is folded exactly

as directed in paper mat, *i.e.* first, lengthways in half and crease, open and fold edges to crease, and fold strip with edges inside. Children should be provided with a bone flattener, used for rubbing seams, and with this the creases should be made. The strip when folded has both sides alike—no edges visible— $\frac{1}{4}$ yard long and $\frac{1}{2}$ inch wide. There will be no fear of the work becoming untidy or fraying if folded as directed. The work can be turned when worn or faded and used again. Cut a square of

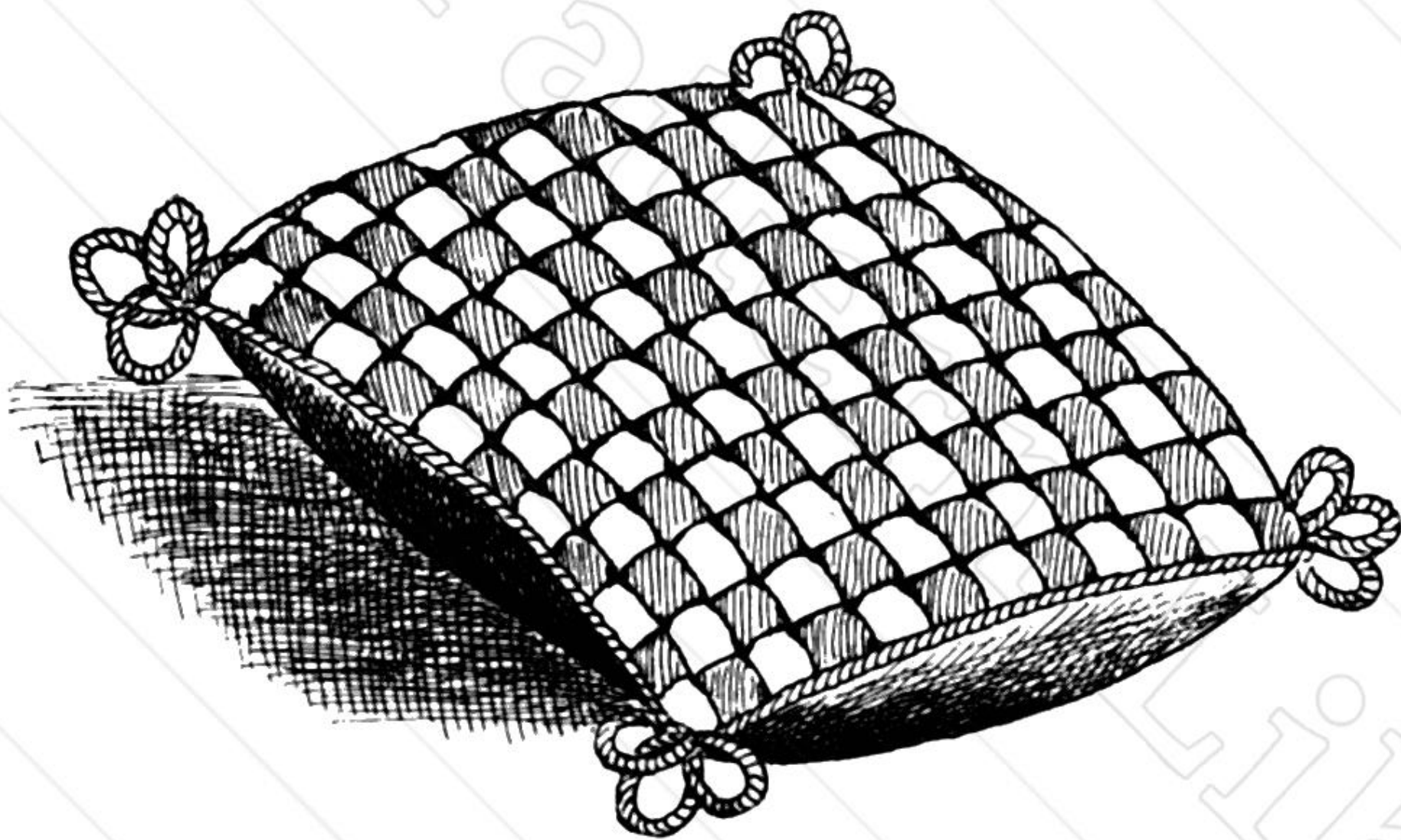

FIG. 60.—Folded Satin Sofa Cushion.

brown paper, 9×9 inches, and let the child pin the green strips top and bottom of the square to form the mat. See that the folded edges all run the same way when fixing. The child must now interlace the golden strips, and must be careful to pass them in with the double edges downwards, and smooth and push them up close each time. The piece when finished looks very beautiful, like most exact patchwork of alternate coloured squares. The fourfold satin gives each square a raised appearance as if padded. When finished the teacher must tack the edges

together and then turn down about half an inch all round. Tack the square of weaving to a plain square of satin of same size, ready for sewing. The sewing must be done on the wrong side, and with silk of same colour. The inner cushion is made of unbleached calico, and filled with bran. Slip the cushion inside of case and sew up. As far as this point every part can be done by a girl of seven years. The cushion is finished off by sewing over the seam a fine silk cord with a twist or two of the same at each corner. Large sofa cushions, as Fig. 60, may be made in a similar way and filled with frayings from the babies' room, or handkerchief sachets and night-dress cases may be made of oblong pieces of the same kind of weaving.

STRING WEAVING

Teachers in want of a pretty and useful occupation will be pleased with string weaving, which the writer has adapted as a supplementary course to the ordinary mat-plaiting, to take the place of Mat V., which is discontinued upon the London School Board requisition.

In every large school there will of necessity accumulate a number of cracked and useless slates, which may be used for this new occupation.

Materials required.—1. Slate frame.

2. Macramé string.

3. Weaving needle.

4. French nails of 1 inch.

Preparation.—Break away the slate part of the useless slates, and clean frames. These may be washed in hot soda water, or, better still, cleaned with a small piece of sand-

STRING WEAVING

69

paper. Either method can be performed by the Standard or upper infant boys, and be thoroughly enjoyed, and form an exciting occupation for one afternoon. This done, write each child's name on a label and attach to slate.

Mark the top and bottom of frame into distances of half an inch, and at each mark insert a short French nail.

Winding.—Take *double* string of either the same or different colours, tie to first nail at the bottom of frame, and wind up and down the frame, keeping the strands vertical (see Fig. 61) until all the nails are used. In winding these foundation strands it is necessary to pull the first and last strands as *tight* as possible.

Weaving.—Measure off lengths of string of another colour for the cross-weaving. This is best done by winding round an empty slate frame, and cutting the string *once* only. Each strand is doubled in half, and the loop end inserted in the weaving needle. Any pattern can be woven, the same as in mat-plaiting, but few look better than the simple one of 2 up and 2 down. The first exercises may be woven with common twine, which really looks very subdued in tone, and can be used plain as it is, or may be embroidered in wool, by working a simple spray of flowers or a geometrical design in cross-stitch upon the plaiting, *before* it is removed from the frame.

Materials.—*Method of Lesson.*—Distribute one frame to each child, a weaving needle, and six lengths of string, cut as above directed, *twice* the width of the frame.

1. Lay slates in position with knot at bottom left-hand corner. Question upon colour of string, whether primary or secondary colours, etc. Count strands in "ones" and "twos." Compare with tight strands of a mat. Teacher to demonstrate on similar slate.

2. Show loose strand of string. Name colour. Take an end in either hand. Double in half.

3. Show needles. Press spring with left finger and thumb. Insert loop of string with right hand.

These exercises should be done simultaneously with the teacher.

Weave across from right to left, unthreading the needle

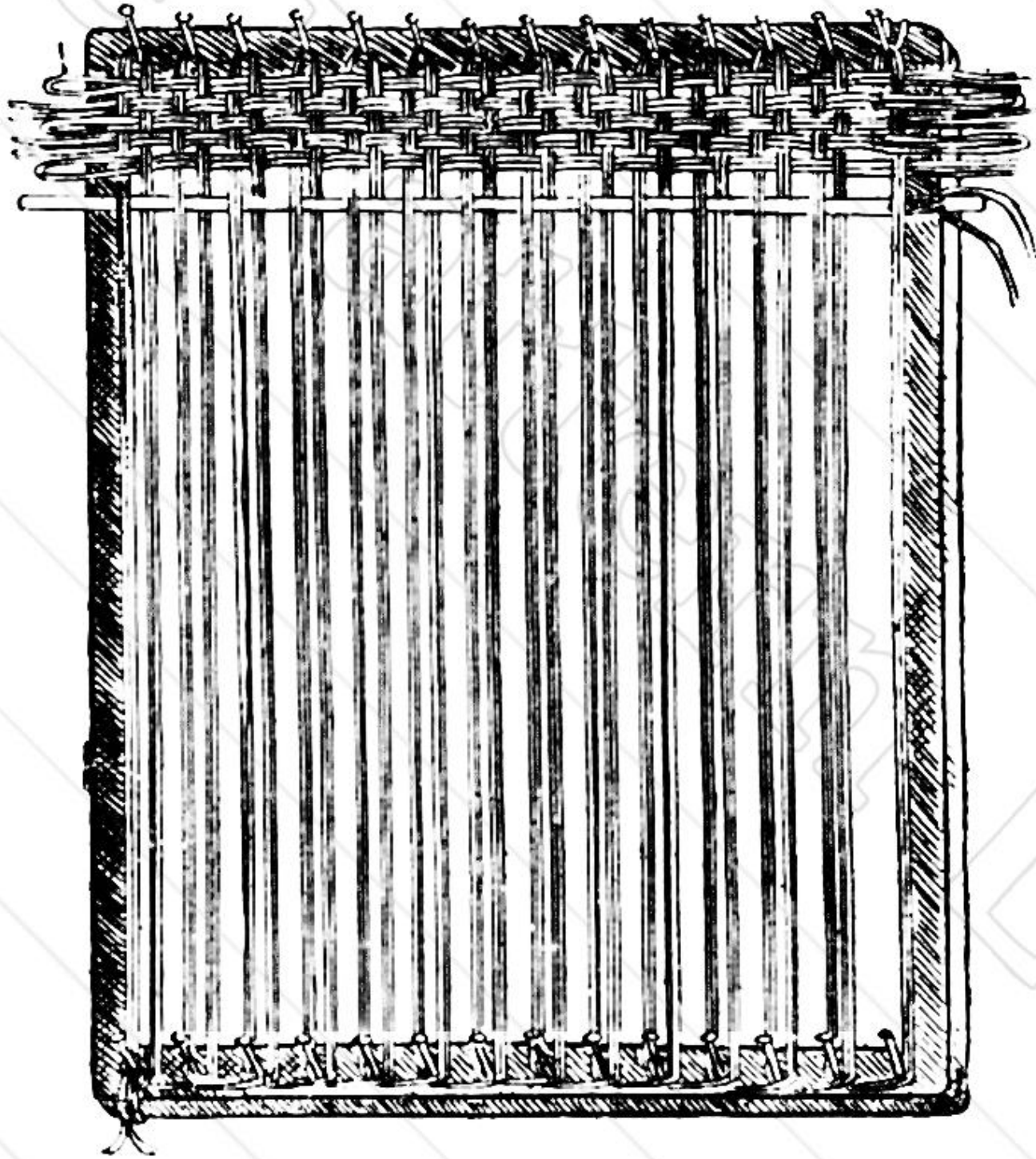

FIG. 61. —Slate Frame.

at the other side. The two strings must be made to lie together, quite flat, and not *twisted* anywhere. See that this point is attended to in every row. The weaving must be done very evenly, and each horizontal row must be at an equal distance from the one above.

How to Finish.—The whole of the weaving being done, the work has to be *fixed* before removing it from the frame. Examine the plaiting and see that the strings are not twisted or uneven, and if satisfactory, *i.e.* tight, regular,

STRING WEAVING

71

and even, paste or gum over the whole of one side whilst still on the frame, and leave to dry. It is best to gum the side which has been uppermost, because the under side of the work will be found fresh and clean, having been kept free from the children's hands.

Plait of String.—Take six or nine strands of string; knot them together at one end, and let one child hold the knot whilst another plaits three at a time, in the ordinary plait of three.

The plait must be fixed on the article by an infant teacher, and small bows of ribbon attached to hide any unsightly joins of the plait.

TOILET TIDY

Materials.—*How to Utilise.*—The tidy consists of: (1) Two pieces, back and front. (2)



FIG. 63.—Toilet Tidy.



FIG. 62.—Plait of String.

(3) Colours, brown and pink strings. (4) Plait of brown string made according to directions given above. (5) Bows of pink ribbon. Cut out in stout cardboard the shape of the article to be made. Snip the looped strings at each nail, and remove the work from the frame. Place the cardboard pattern upon the weaving, and gum or tack it firmly to the work, and cut to shape. Cover the *under* side with silk,

sateen, or leather paper, and bind the edges with ribbon, and ornament with a plait of string to hide the stitches. The work may be rendered much more attractive by using a variety of colours, and it forms a splendid exercise for teaching combination of the same. The work is useful in many ways, as it forms a suitable supplement to the ordinary mat-weaving occupation, and can be mounted and cut to any shape for manipulation into table mats, toilet tidies, etc.

If large pieces of work are required, they can be made upon an old picture frame, or a rough one could easily be made of four strips of cardboard, but a number of slate frames will be found best for use in large classes.

A ROUND MAT

Very pretty round mats for vases and ornaments can be made from the piece woven on an ordinary slate frame. To finish these off, an ornamental loop fringe is easily made in the following way:—

1. Give each child a wooden 12 or 6 inch flat ruler as used in the school, and a small *ball* of string.
2. Tie the end of string tightly round the ruler.

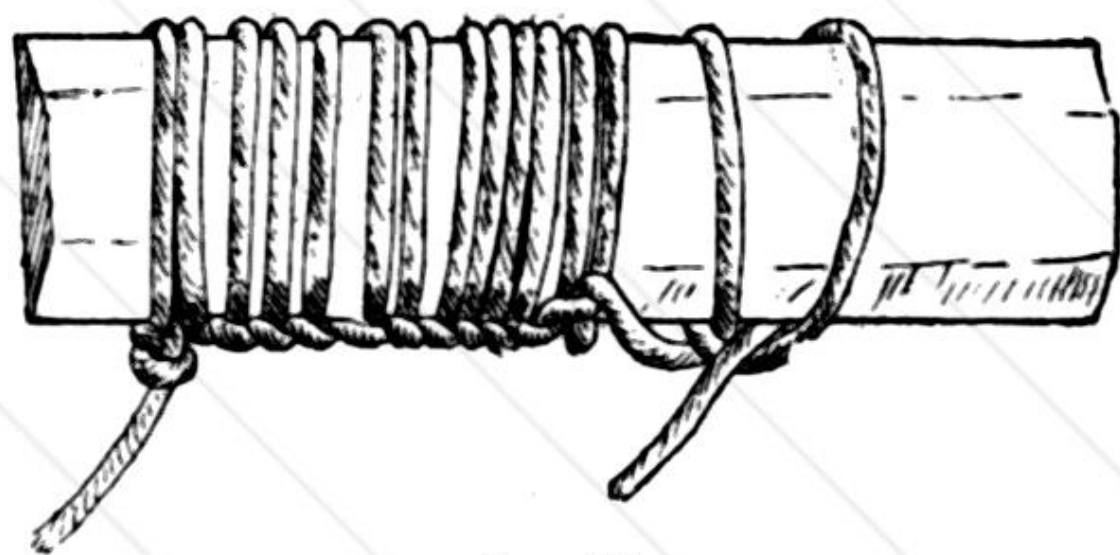

FIG. 64.

3. Hold ruler in left hand, and with ball in the right, teach simple button-hole stitch.

When the ruler is full, the teacher or child should oversew the buttonhole edge with a needle and thread to secure the loops from untying. This done, slip the loops off the ruler from time to time, and knot

STRING WEAVING

on more string and continue the fringe until the piece is of the required length for mat.

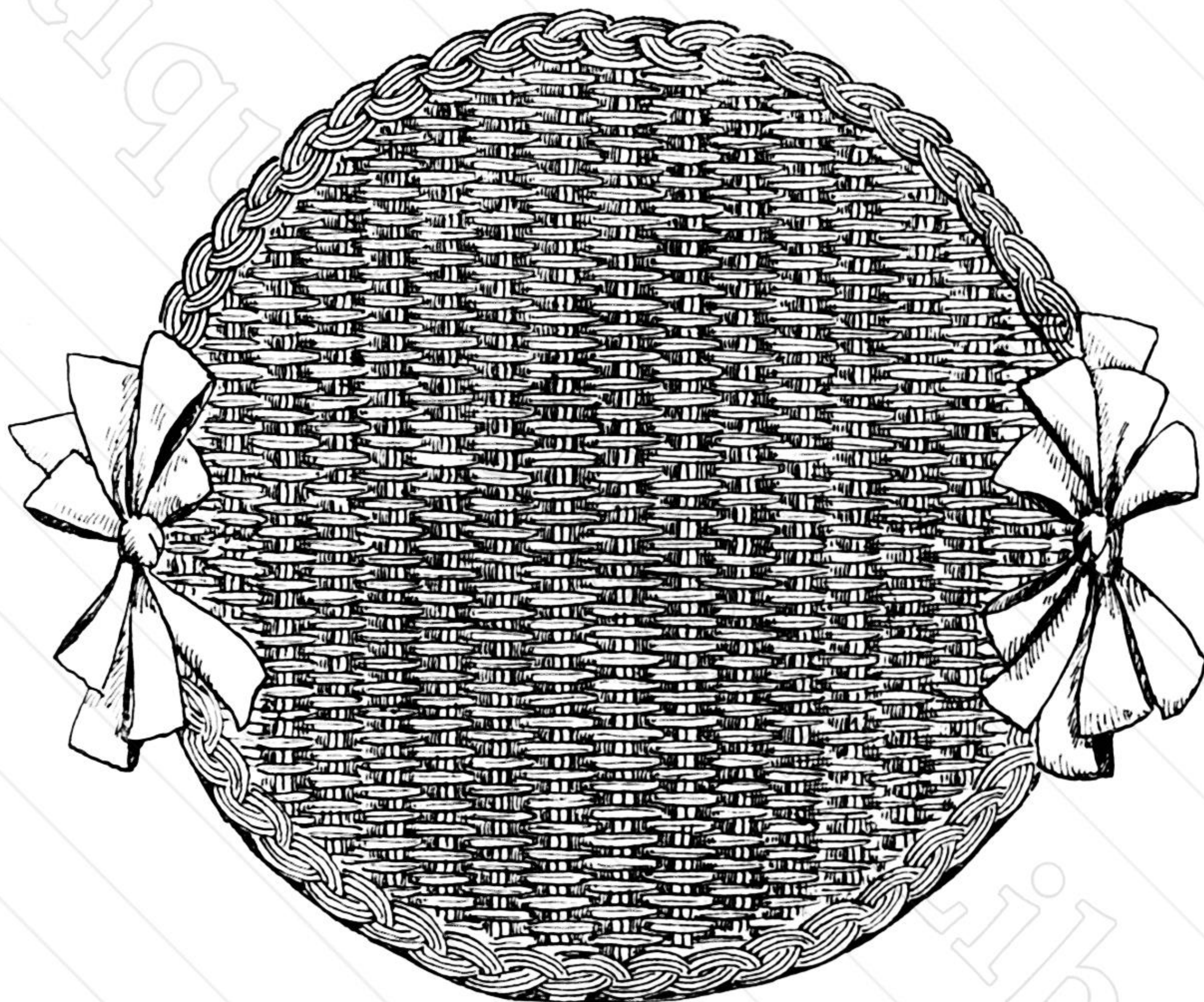

FIG. 65.—Round String Mat.

Sew the fringe round on the extreme edge, and finish with a plait as described above, and bows of ribbons.

Wool may be used instead of string, and the finer the string the more delicate and beautiful will be the weaving.

The Macramé string may be had in all shades and of three different sizes.

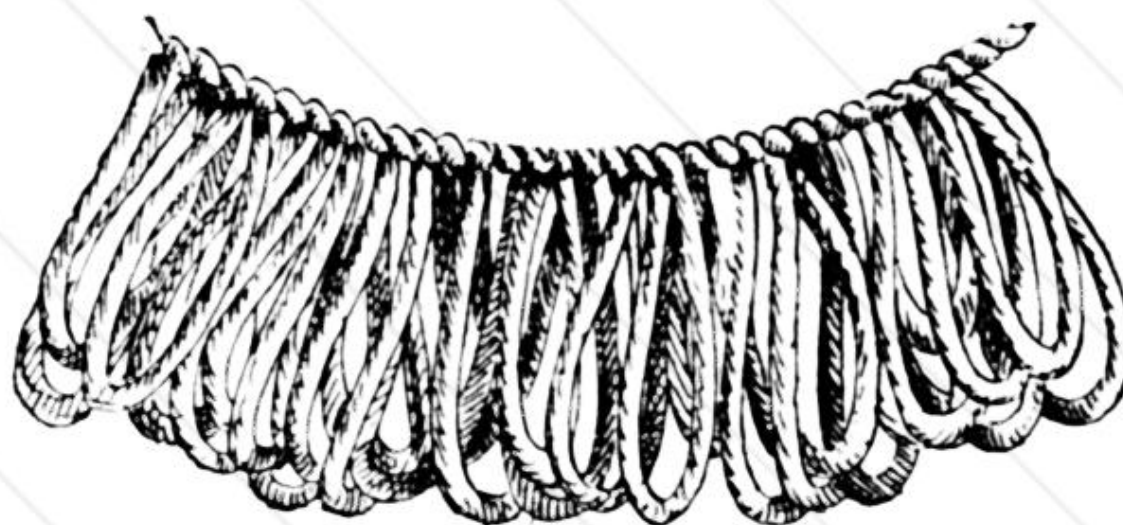

FIG. 66.—Fringe complete.

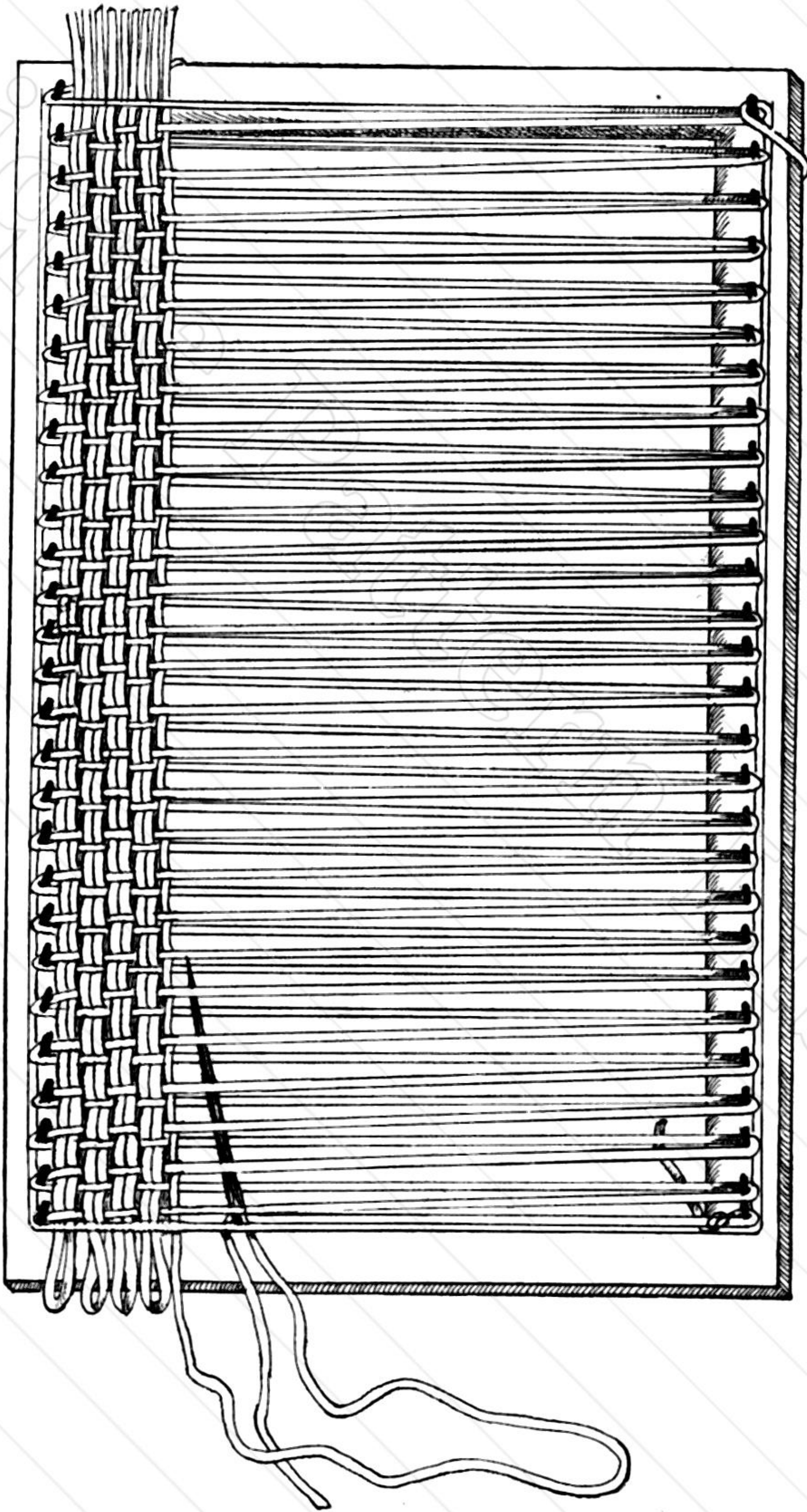

FIG. 67.—Weaving Frame.

STRING WEAVING

75

WEAVING FRAME

The frame in Fig. 67 is called a weaving frame. It is made of wood and measures 19×12 inches. The long sides are intersected with thirty-eight fine points, upon which the materials are fixed or wound. The frame is made for list weaving, but may be used equally well for straw plait or ribbons, or wound with string or cane to represent in each case a flat mat for weaving. The points are covered by strips of cork when weaving.

In string weaving the ordinary Kindergarten needle is useful for the purpose. The string should be doubled in half and the loop end fixed in the needle, and thus a double row is worked each time. The long demonstration needles of *12 inches*, supplied with the "Paragon Sewing Sheets," are also very good to use upon this frame. The string then would have to be used singly, but the string might be cut a sufficient length to work three or four rows without joining.

STRING HANDBAG

Materials required.—1. Macramé string, No. 4.

2. Weaving needle.

3. Weaving frame.

Method.—If a weaving frame is not to be had the teacher might make one by nailing four pieces of wood together and using short French nails for the points. This done, wind the string up and down on the points, as shown in Fig. 67. Then with Kindergarten plaiting needle or long demonstration needle weave across the frame in the same or a different coloured string. When a piece the full size of the frame, 18×12 inches, has been woven, then lay

across one end a simple outline of flowers. This pattern must be traced on paper and the paper tacked upon the weaving. With wool and needle the pattern is covered with long stitches. In Fig. 68 the pattern is a spray of leaves and blue flowers. The stem and stalks are sewn in brown wool, the flowers in blue, and the leaves in different shades of green.

The under side of the work is now pasted over with



FIG. 68.—String Handbag.

thin paste to keep the weaving intact before being removed from the frame. Slip the work over the points and tack the same to a piece of stout canvas for support. Edge it all round with a plait of string, as shown in Fig. 68. The piece of work is now doubled in half to form a bag, and is lined with a full lining of blue sateen to match the shade of the flowers. The gathered sides have a running of elastic to allow them to stretch open. Two handles of plaited string are attached to the sides.

DIAGONAL WEAVING

This occupation is a very suitable one to supplement diagonal mat-plaiting, because the principle is the same, and the children will be able to proceed without much assistance from the teacher after one or two lessons. It may be utilised for making many useful articles in addition to its educational advantages.

Materials required.—1. Old slate frames with holes drilled three-quarters of an inch apart on each side of four corner holes.

2. A small wooden pegger, or wooden signal reading pointer, as used by the children.

3. Macramé string of different colours, No. 5.

Method of Teaching.—Have all the slate frames cleaned and uniformly drilled with quarter of an inch holes on all sides about three-quarters of an inch apart, making the corner holes first.

This done, label each slate with child's name and distribute to class, with a pegger or reading pointer. If reading pointers are not used in the school, the teacher should use firewood, and sharpen a 3-inch stick for each child. It must fit into the holes of slate, and will be used as a wedge to prevent the string from slipping as the weaving proceeds.

Beginning.—Pass the thread *down* into No. 1 hole, and tie the string to the inner side of the slate frame. Pass across to No. 2 hole opposite and thread *down* No. 2 and *up* through No. 3. Pass across to No. 4, and thread *down* and *up* on opposite side. Continue thus till side of the slate is full.

The threading is carried on on one side of the slate

only; the children will soon perceive that the rule for threading is "down and up" on one side of slate, cross over, and repeat on the opposite side. When all holes are threaded, pull the string tightly, and secure the end for the present by winding it round the adjoining side of frame.

Turn slate round, *i.e.* top to bottom, and let the last threaded hole come at bottom left-hand corner.

Begin again in this hole, and proceed again exactly as

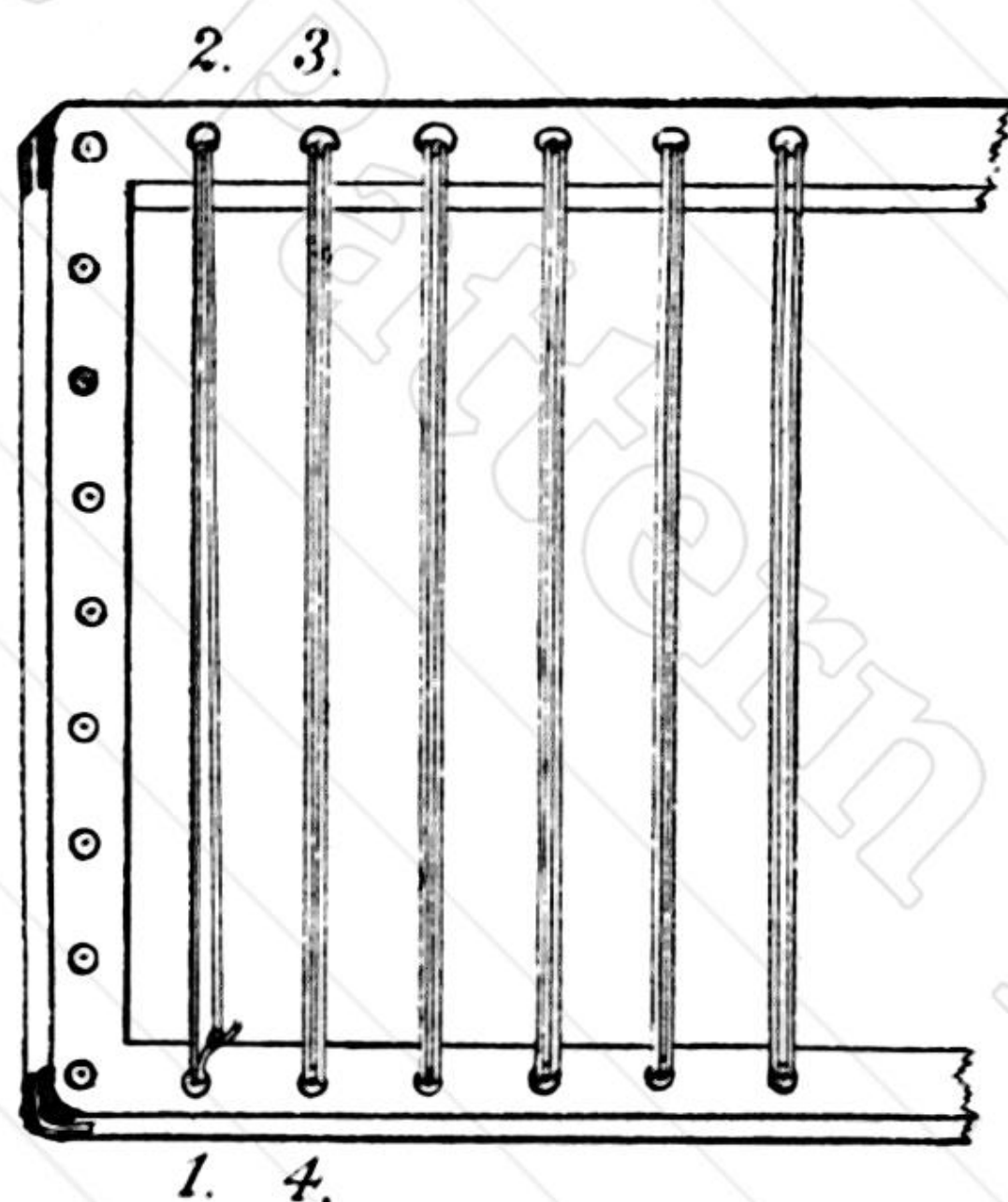

FIG. 69.

before. Tie on a second string, and weave into the same holes until a double string proceeds from every hole.

The two ends will be on opposite sides of the slates, and both these should be of same colour, *e.g.* red.

The cross strings must be of a *different* colour, and may be green.

Knot to each end of red a green string sufficient to weave throughout the several lengths of the slate. The knot must be made to come underneath the frame, and will lie *across* the corner hole. The new colour is threaded up

DIAGONAL WEAVING

79

on either side through the hole *next* to the corner. The right-hand thread is woven across, 1 up, 1 down, to the opposite side, and threaded *down* into the *same* hole from which the opposite thread proceeds. The left-hand thread is next woven across from left to right, reversing the weaving of the right-hand thread, and the end is threaded *down* into the same hole as the first cross strand. Both are pulled tightly and one side is pegged, whilst the other is worked. Both ends are next threaded from underneath *up*

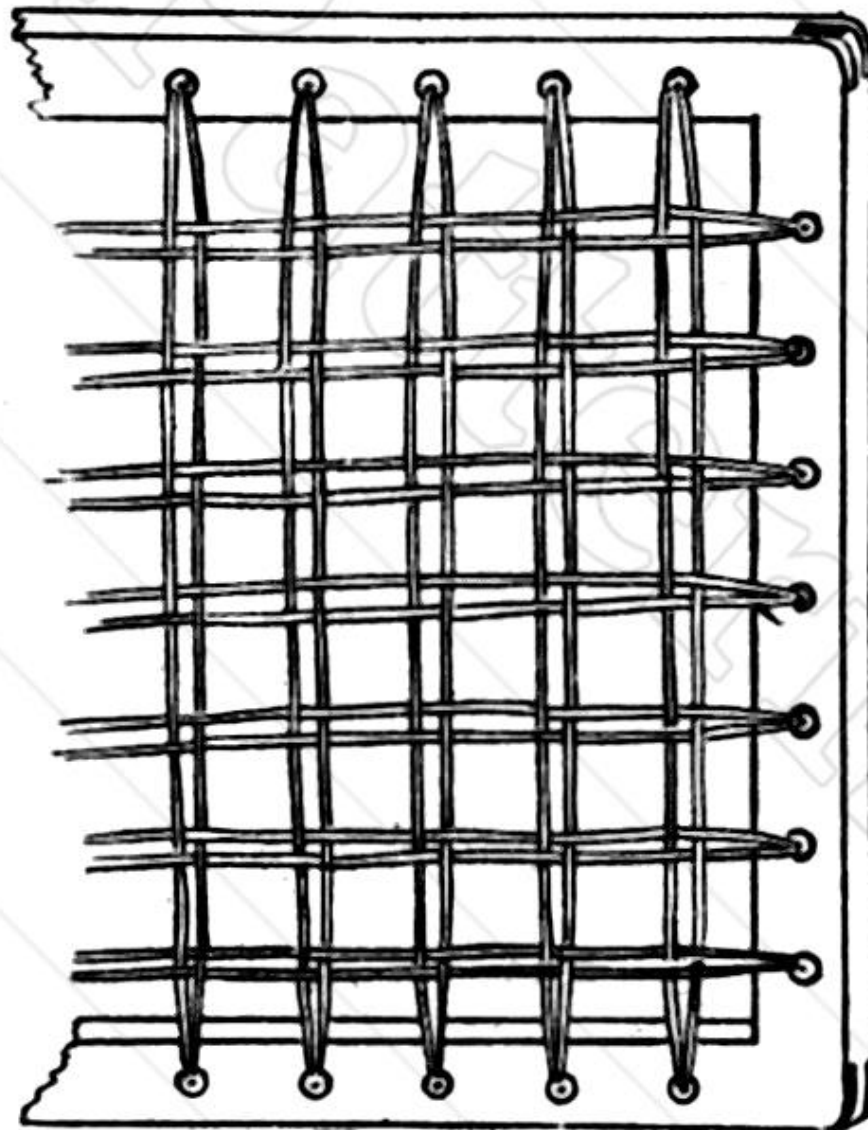

FIG. 70.

through the second hole on each side. They are both woven across as before, and passed down into same holes, pegged, etc., until the sides of slate are complete.

Diagonals.—Knot to each end of the green string a pale yellow or cream thread. If the holes are to be secured with wooden pegs, the diagonal strings could be cut in lengths, but a long string can be used and threaded from hole to hole in the same way as the first two colours.

Place the slates lengthways, with the *red* strings vertical and the green horizontal.

Give the rule that the weaving is to be in a *slanting*

direction, and the *double red strings* are each time to be "*lifted up*," beginning at the corner. As the slates are not square, the first diagonal will come out on the top *side* of the slate, and not in the opposite corner. Thread the string, down and up, through next hole and continue back again across, "*lifting up*" the *double red thread* till all the diagonals are done one way.

The corner holes are used for the diagonal strings only.

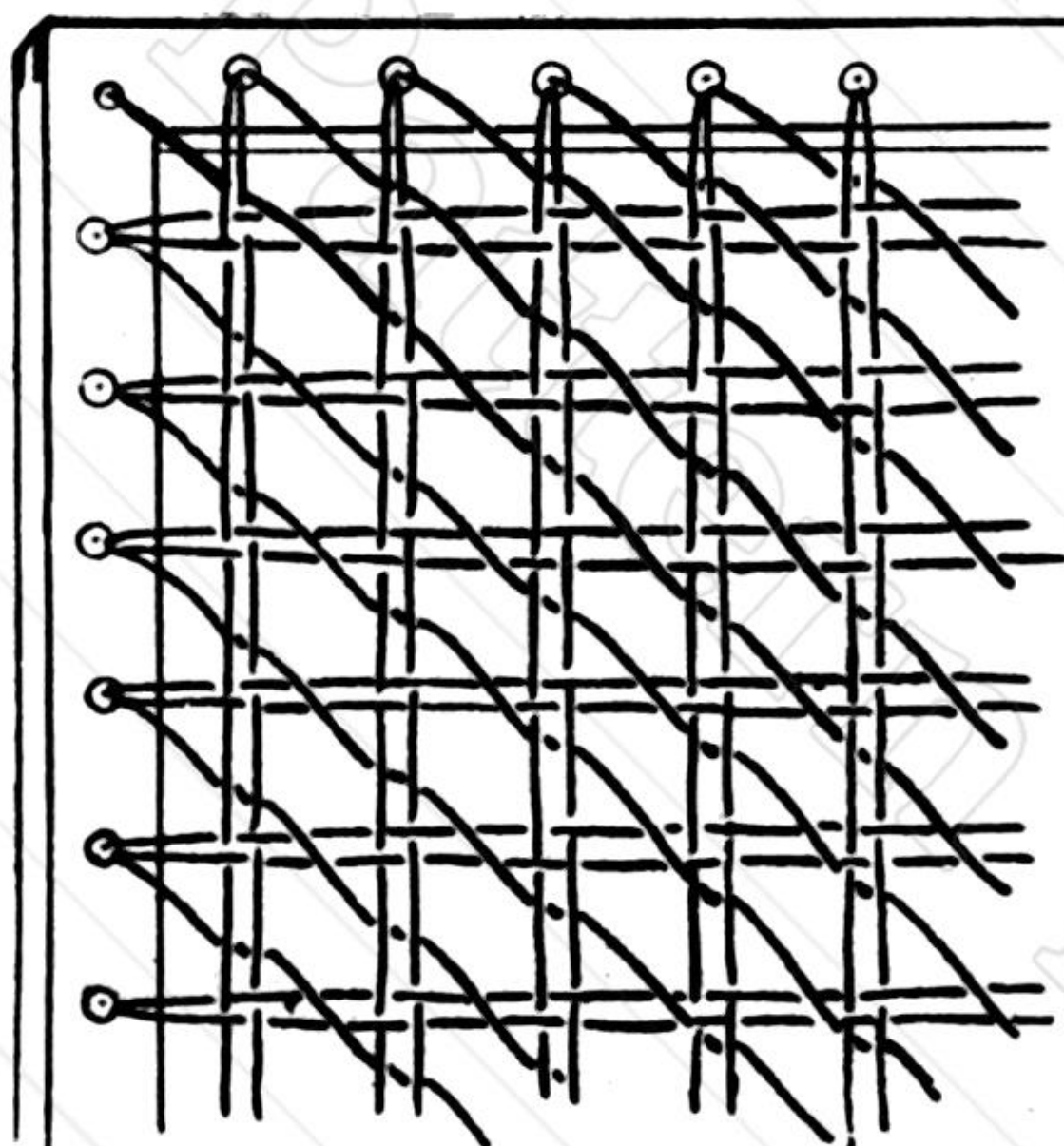

FIG. 71.

Second Diagonal.—Turn slates round with the *double green strands* vertical, and proceed with the second diagonal in precisely the same way as the first, viz. "*lifting up*" the double green strands. The weaving, although the same to the children, is exactly the reverse of the first diagonal, and is thus managed by simply turning the slates, sides to bottom. The different colours used for each weaving is one great aid, and the *one* rule of "*lifting up*" the *verticals* when crossing the diagonals is another.

The diagonal strings must not touch each other, but

DIAGONAL WEAVING

81

must cross one *over* and one *under* upon all the double red and double green strands. These double strands must not be separated in the diagonal weaving, but treated as one.

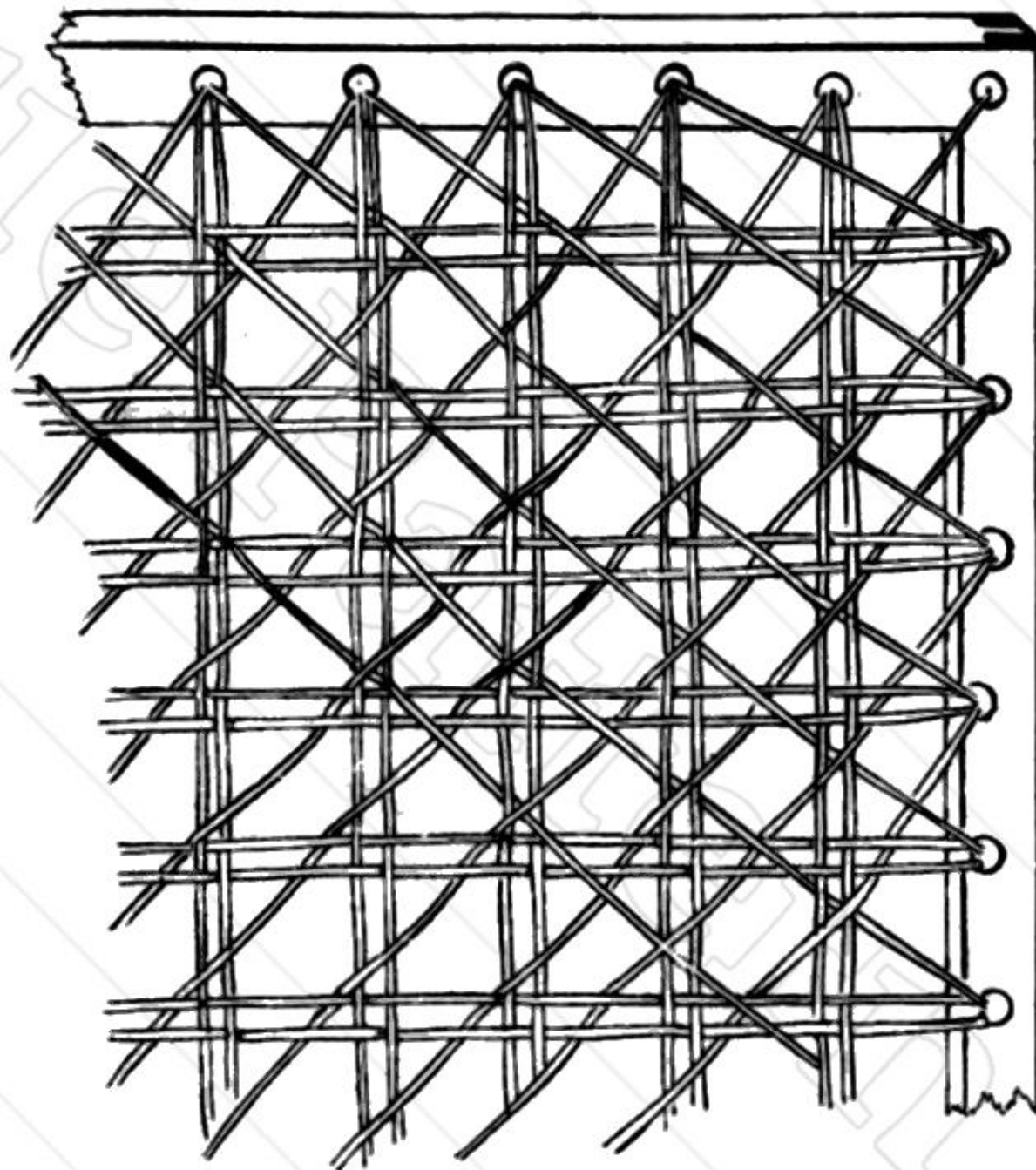

FIG. 72.

Finish the ends by pegging them tightly with wooden pegs into the last holes threaded *down*.

Note.—Any chair-seat, window blind, or stool may be admirably worked in string by the children, and will be found quite as durable as cane. See “How to Cane a Chair,” and follow the same plan, using Macramé string instead of cane.

DOLL'S BEDSTEAD

The doll's bedstead is made of ordinary cotton reels and a slate frame.

Wash frame and reels thoroughly in soda water, and,

G

when dry, let child enamel all in post-office red paint enamel.

Weave centre in string or cane according to the directions given above.

Push a round stick through the corner holes, allowing one-third for the legs and two-thirds for the height. Gum

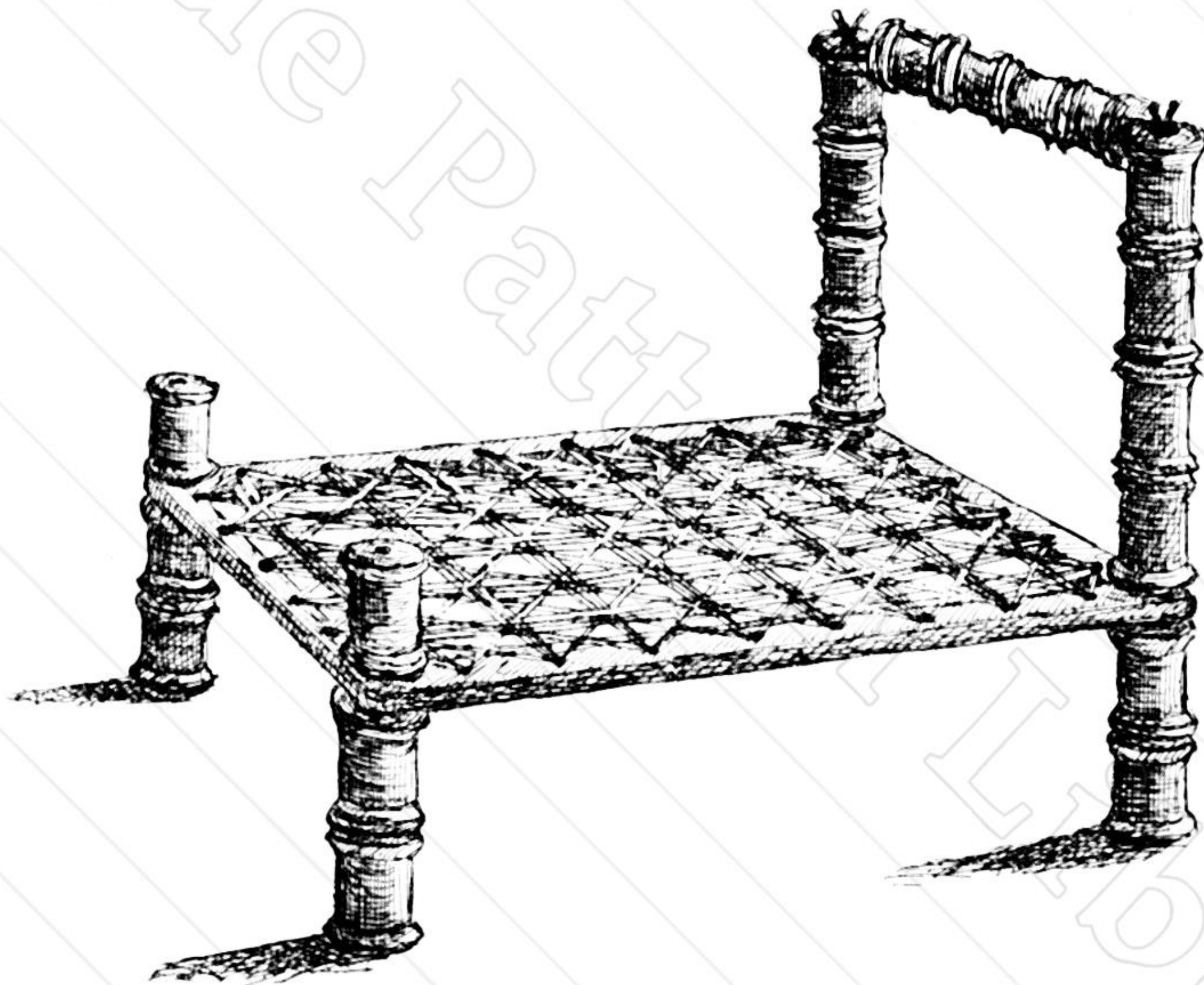

FIG. 73.—Doll's Bedstead.

or glue the reels together. Thread them on the sticks and let the sticks protrude from top reels about three-quarters of an inch. Slit each end, and into the slits fasten the transverse rod of reels to form the head of bedstead.

The bedstead may be frilled and trimmed complete by the children in the various occupations.

The whole was made by a boy of seven years in writer's school.

FRAME WEAVING

No. I.

Frame weaving is really advanced "Star Winding," only that the designs have more angles, and are larger and require greater thought and manipulation. The small stars are made of ordinary cardboard, and are easily wound in

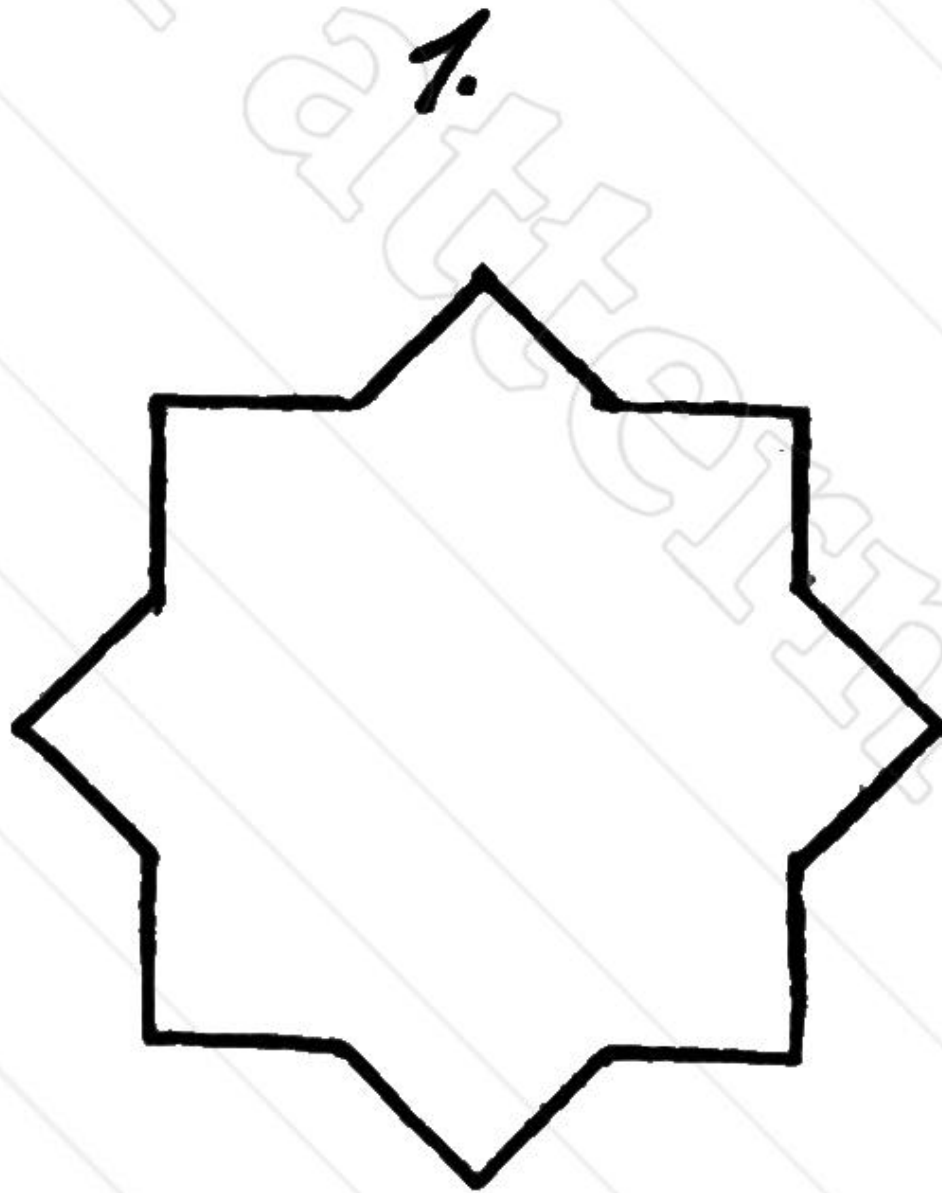

FIG. 74.

the hand, whereas "frame weaving" treats of a stout and substantial foundation, enabling the worker to pull and strain without injuring the shape. These frames are really works of art when woven in Strutt's fine Macramé twines or crochet cottons. They are most suitable as frames for pictures, but may be utilised for lamp mats, key racks, etc., by substituting a piece of velveteen or plush for the centre instead of a picture.

Messrs. Strutt manufacture forty-two different sizes,

of ten distinct shapes of frames, some of which are furnished with a circular mirror, or frame for cabinet portrait.

The smallest size of each shape begins with the lowest number. The shapes suitable for school purposes are—

1. The Star (sizes 1, 2, 3, at 10d. to 2s. per dozen).
2. The Sun (sizes 4, 5, 6, at 1s. 3d. to 2s. 3d. per dozen).

2.

3.

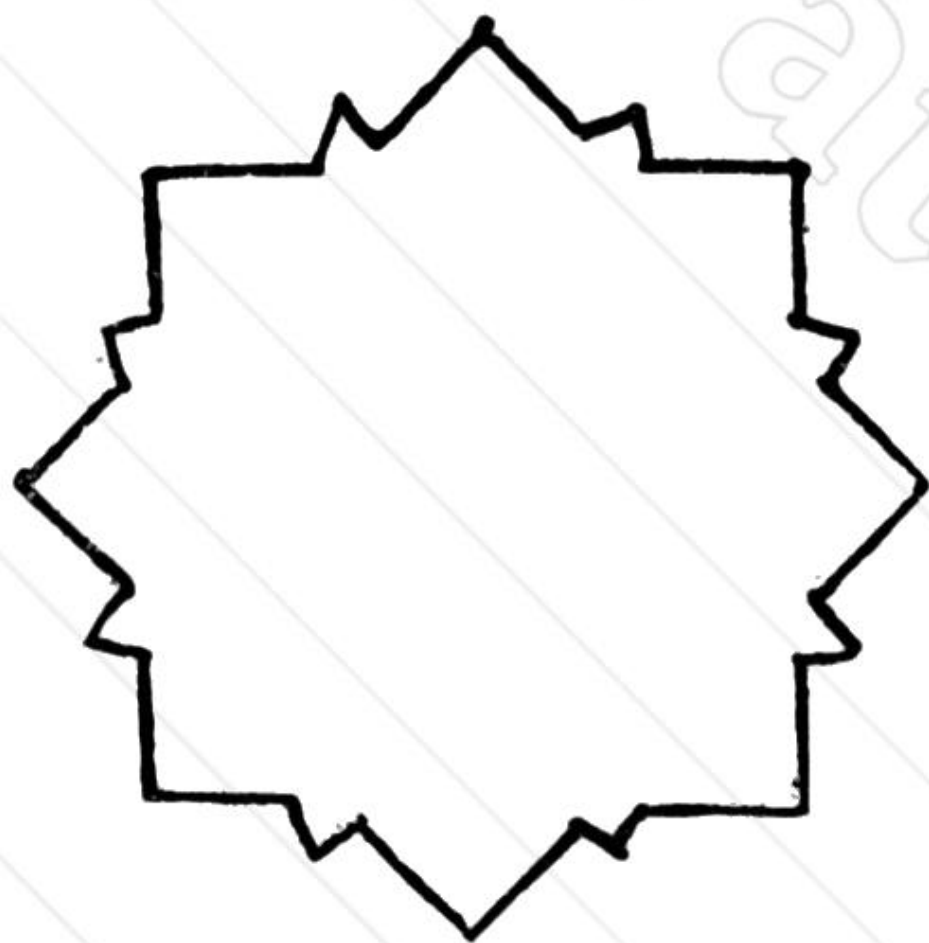

FIG. 75.

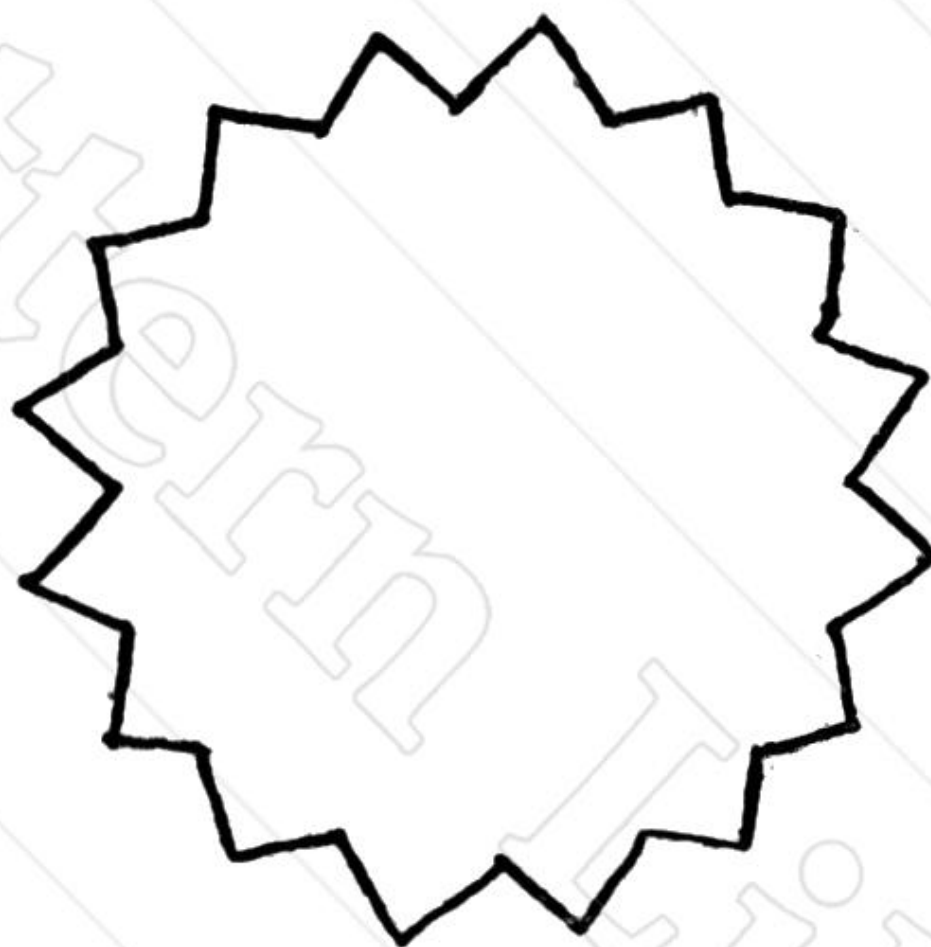

FIG. 76.

3. The Circular (sizes 7, 8, 9, at 10d. to 2s. 8d. per dozen).

4. The Belper (sizes 10 and 11, at 1s. 6d. to 2s. 9d. per dozen).

Materials.—Strutt's fine twines, No. 10, or Strutt's crochet cottons; both are manufactured in beautiful artistic shades and sold in boxes of 3 lbs. at all Kindergarten depôts.

Method of Teaching.—The work is suitable for and quickly understood by children of six years who have previously been through a course of "Star Winding." No. 1

star is the simplest to take for the first lesson, as the children are familiar with the shape.

Examination of Frame.—First let children examine the star and count the number of points and angles.

A general rule for winding is to divide the number of points by four, and enclose *one* more than the dividend. Thus, a star of eight points divided by four would give *two* add one extra, and that will be three points to be taken in winding. Teach children this simple rule and sketch on blackboard the frame in question, and dot off the section to be enclosed in the winding.

4.

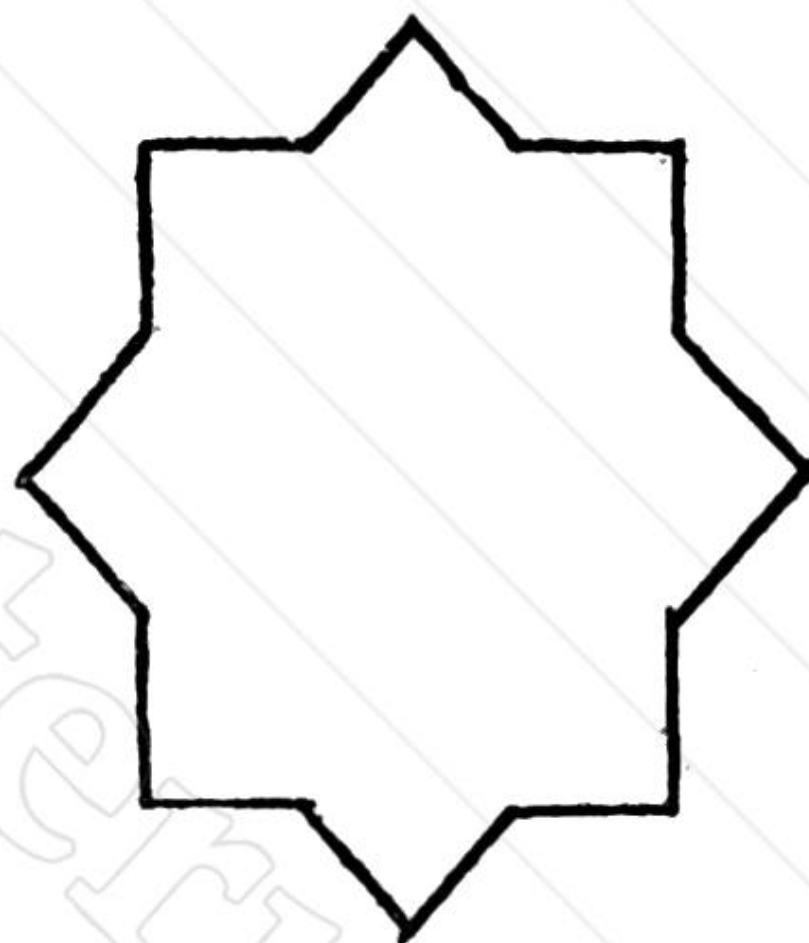

FIG. 77.

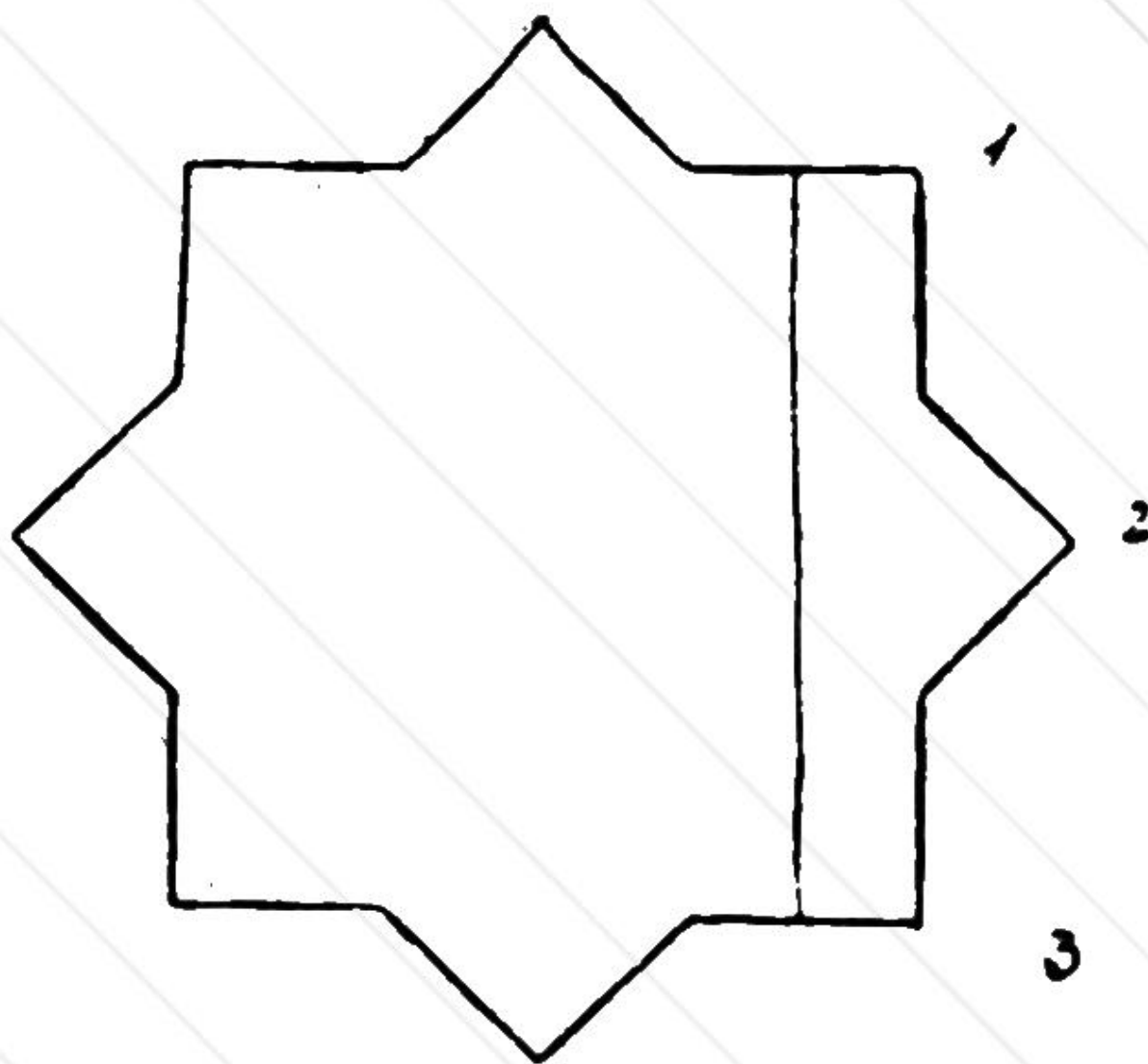

FIG. 78.

Choice of Colours.—A centre must be fixed before the

winding begins, and upon the centre the choice of colours must depend. At first, pretty Christmas cards will do as centres, but later on portraits, crayon drawings, embroidery and crewel work, cut-out sprays of flowers, pressed leaves, etc., might be prepared in the different classes, and then preserved in these frames by placing a piece of glass

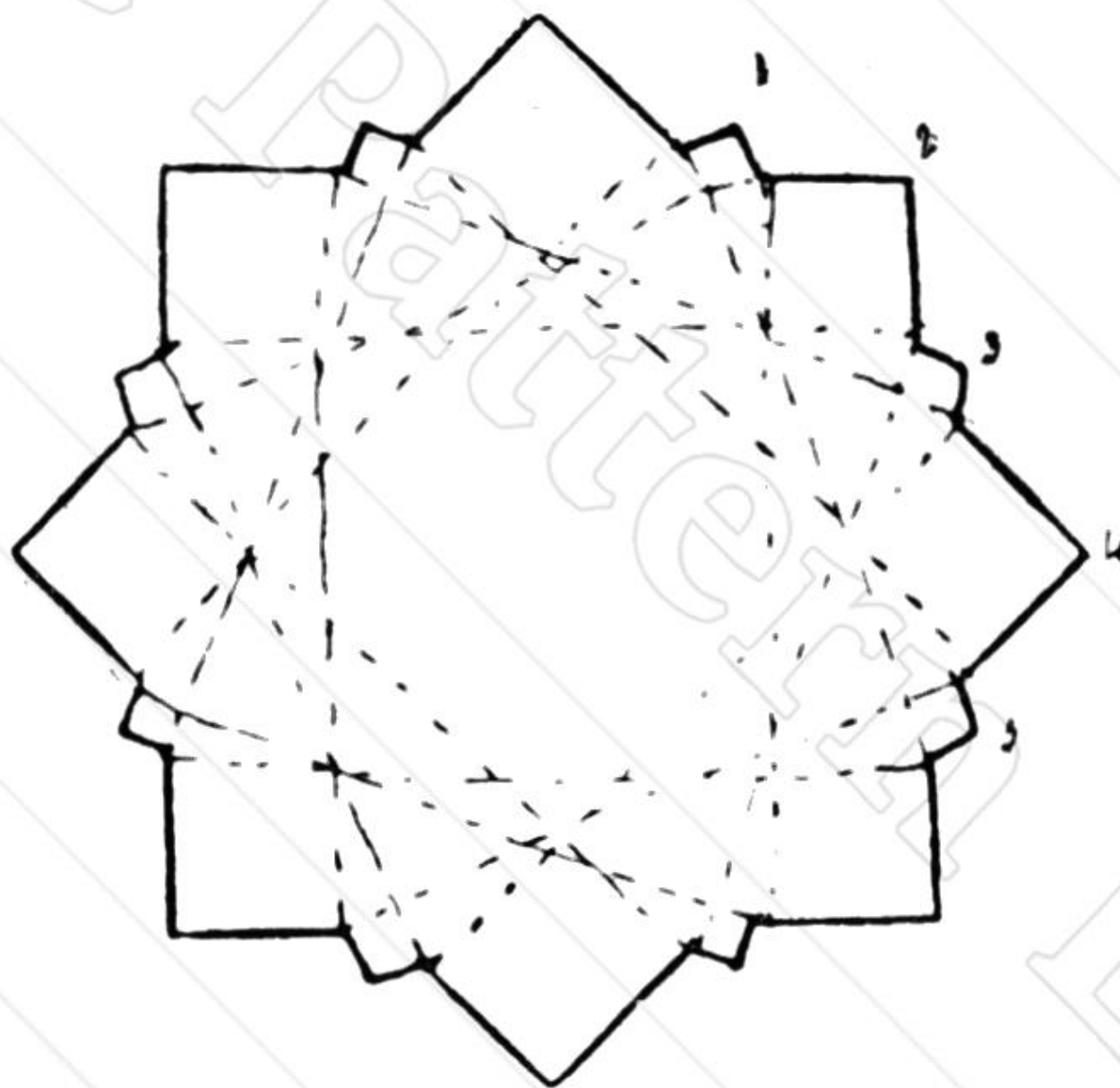

FIG. 79.

over the work. Pierce holes, and tie the glass tightly in position until the weaving is done, when the string across the glass will be concealed by the weaving, and will hold the centre securely in position.

Let children look at their pictures, and decide upon the prominent colours. Whatever they may be, the twine or cotton selected should harmonise or be a direct contrast. Much depends upon the taste displayed in choosing the colours.

FRAME WEAVING

87

No. II.

Materials required.—1. Strutt's fine twine, No. 10, or Strutt's crochet cotton.

2. Frame No. 1 of the star shape.

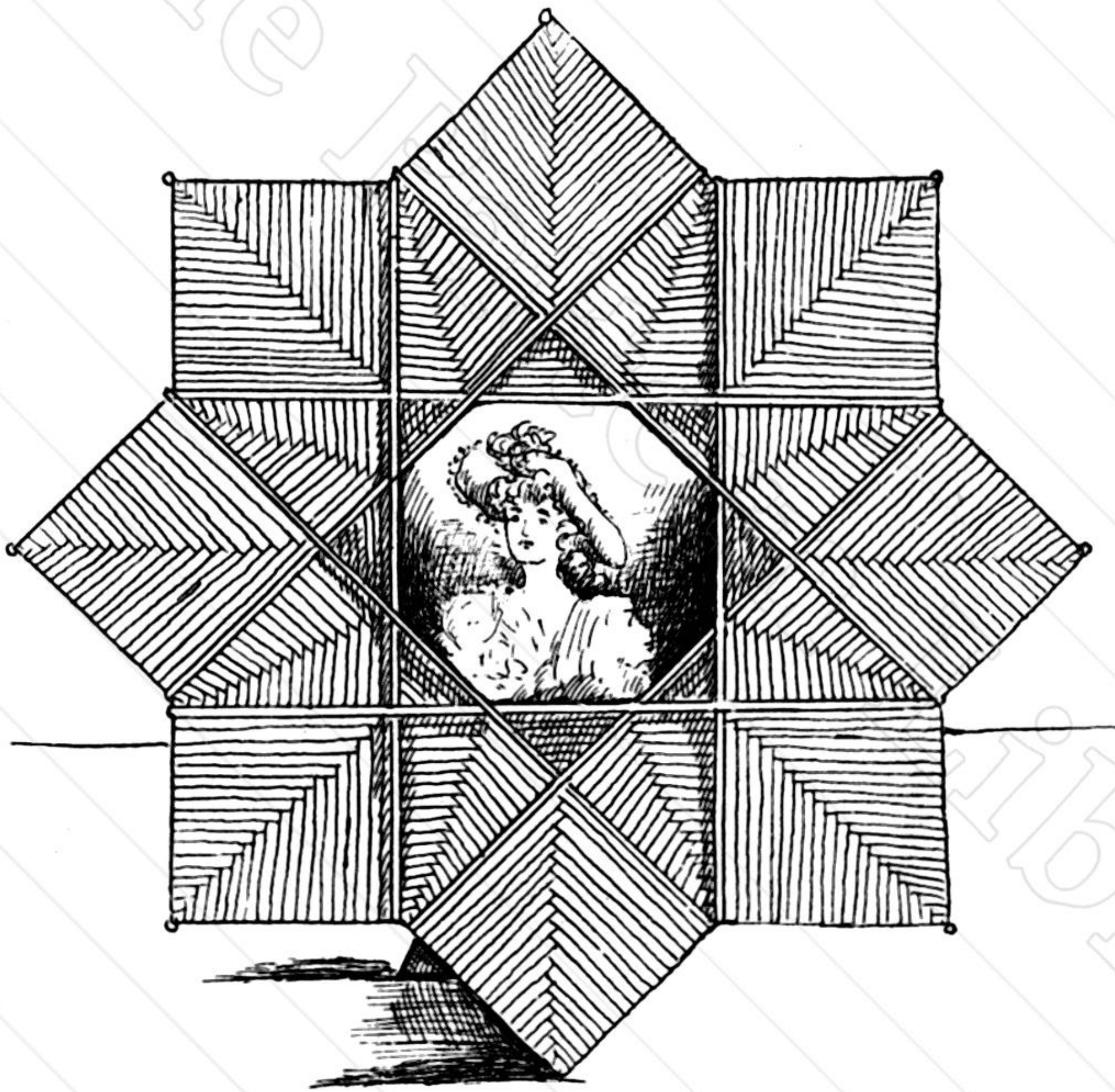

FIG. 80.—Picture Frame.

3. Brass-headed nails.

4. Picture for centre.

5. Large brown paper bag, with name affixed.

Pattern.—Star No. 1. A star of eight equal points, formed by a square placed across a square. Lead children

to see this, and dot the outline of the two separate squares on the blackboard.

Centre.—A photograph placed under a square of glass and tied in position until the winding is finished. Pierce

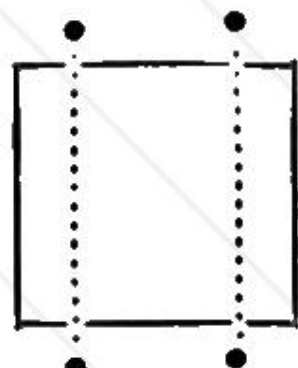

FIG. 81.

four holes through the foundation, and thread the string through them and tie at back.

Winding.— Push a small brass-headed nail into each point to keep the strings from slipping off, because this pattern begins *at the points* and works towards the corner. Tie the string round the three points, keeping the knot at the back, and let the first row lie quite at the edge from point to point. Wind three or four threads on this section, then turn the star one point and take the next set of three, and continue to wind in this manner all



FIG. 82.

round the star. One colour may be used for the entire frame; but a variety is very effective. This is managed by knotting on a *different* colour for the *eight* different sides. The different colour used must be wound on the same side at each successive winding. The illustration was worked in two colours, viz. brown and pink, and the alternate colours were used each time the star was turned, giving alternate corners of pink and brown. After the star has been wound all round (three or four threads) at the outer edge continue in a similar way round the star again, beginning with first colour, and let all successive windings lie close to the last, and so continue until the rows of string quite fit into the corners, and the star points are completely covered.

FRAME WEAVING

The frequent joining of the colours may be a little troublesome, but if the children have a knowledge of star-winding and are taught to knot their own strings together, this pattern need present no difficulty if each child is provided with the necessary balls of string and brown

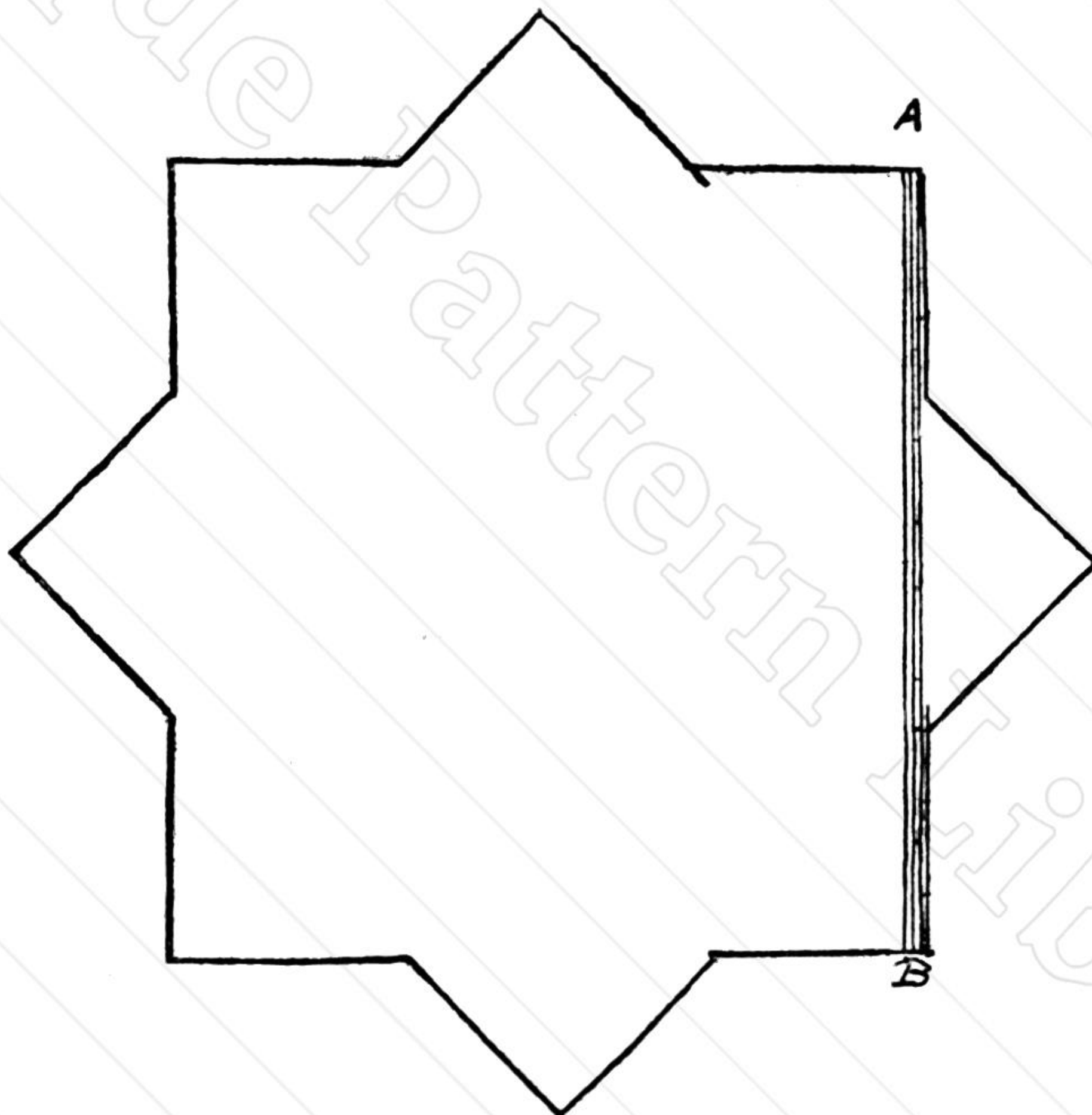

FIG. 83.

paper bag. Finish off the last end by tying it securely to the string at back.

Cut a cardboard stand, and cover in leather paper. Make a hinge of leather or material, and fasten to cardboard stand, and to the top of star at the back. The frame is suitable then for standing on a table, or if desired, can be

suspended by cord or ribbon. The pattern described gives a raised centre, graduating lower *towards* the points, but the reverse effect is obtained by starting at the corners, and winding *outwards* to the points.

Although the winding is similar and easy for the children, two different colours will give quite a changed appearance to the pattern.

No. III.

Materials required.—1. Star shape ; No. 3, in pliable cardboard.

2. Strutt's crochet cotton.

3. Bead-headed pins (crystal).

4. Picture for centre.

Method.—The patterns taught in this article are the exact reverse of the preceding one. The children should first wind flat cards in the pattern before they attempt to pull up the points to form a basket.

Pattern 1.—Star of eight equal points. Begin in the angle or corner, and wind six threads outwards towards the points in one colour, turn and repeat on all seven sides. A second colour may be used or not in the succeeding rounds. Fig. 84, A to B, shows where to begin, and the section taken in winding each time, 2—2, 3—3, and so on.

Pattern 2.—Begin at angles and wind towards points, using six threads and alternate colours *each round*.

Pattern 3.—Begin at corners and wind towards the points, and use a different colour for the second section or side. Alternate the two colours each time the card is turned, thus producing four sides and four corners of one colour and four sides and four corners of another.

Pattern 4.—Begin at corners, wind towards the points,

FRAME WEAVING

91

and use eight different colours, one for each side, keeping one colour to the same side throughout.

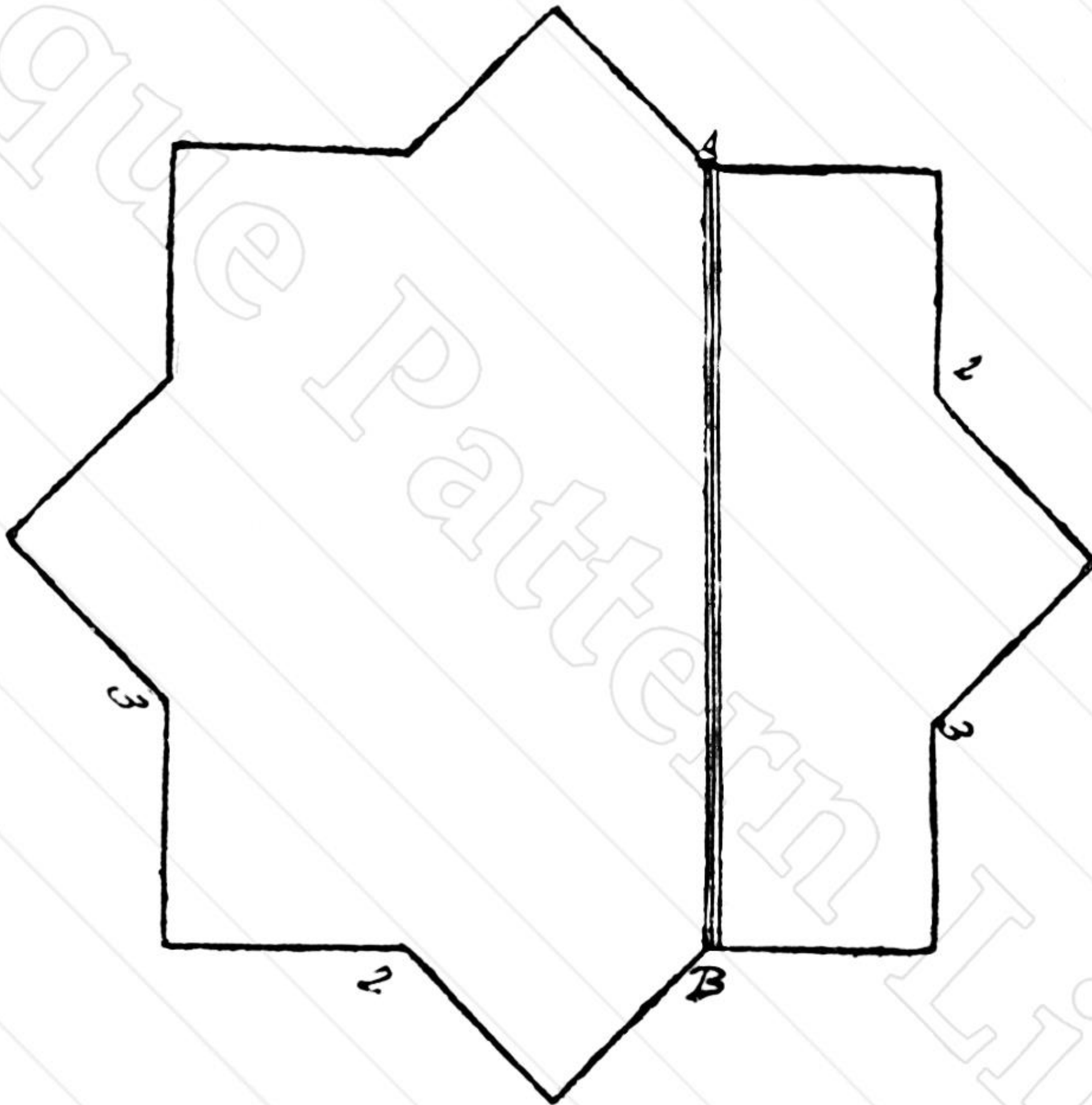

FIG. 84.

CARD BASKET

Materials required.—1. Large star, cut in pliable cardboard, measuring 10 inches from point to point.

2. Blue balls of crochet cotton.

3. Yellow-tinted picture.

4. Crystal-headed pins.

5. Ball of silver tinsel.

The foundation must be cut in pliable cardboard, so that

the points may be gradually pulled up, as the weaving nears the points.

This pretty basket is wound in pale blue crochet cotton, according to pattern No. 1. Fix a Christmas card in the centre with gum, and then tie the cotton round the section, with knot at back, and let the first thread lie exactly *in the corner*. Weave six threads each time, and continue winding the whole star in the one colour. As the weaving

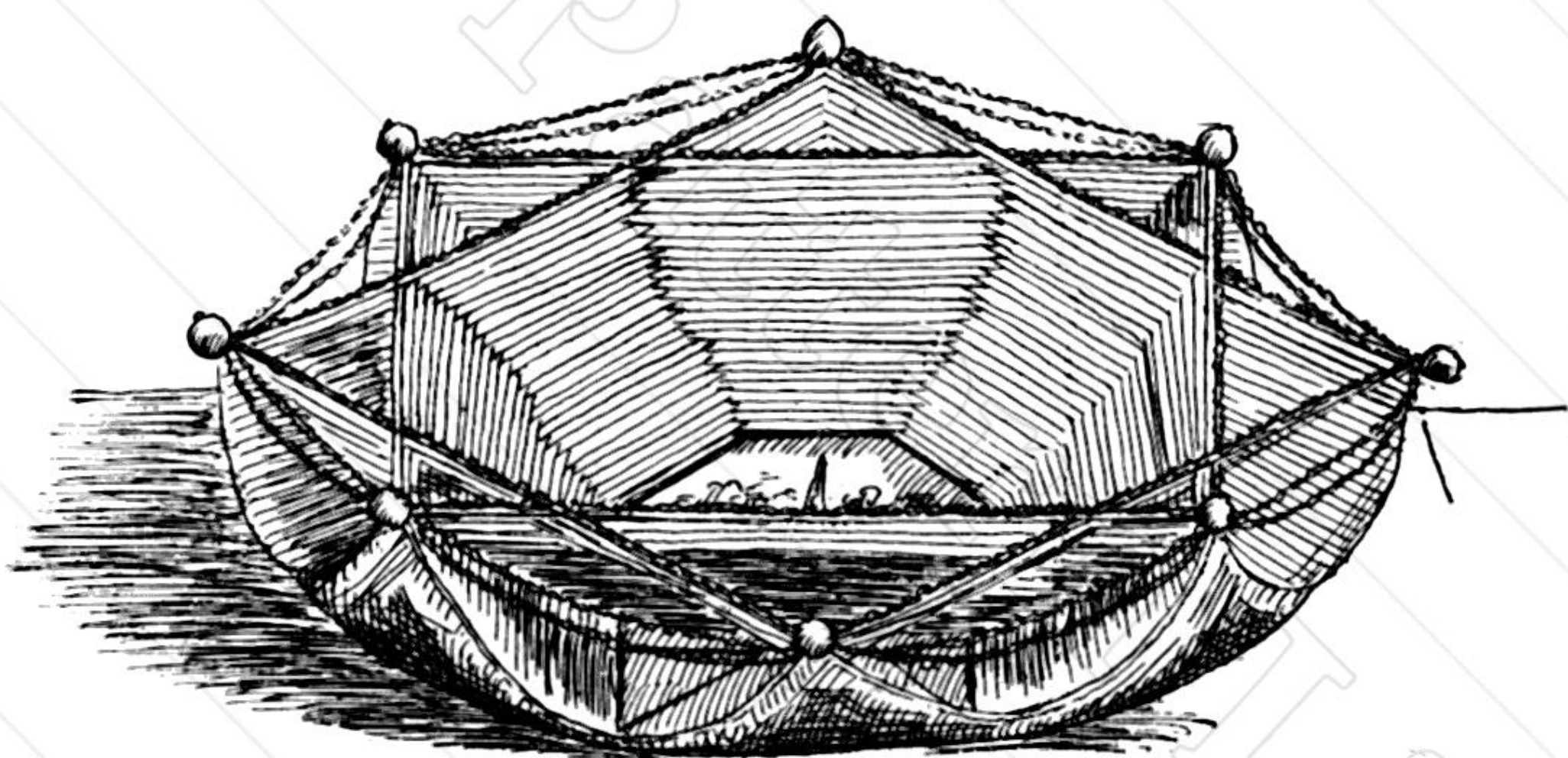

FIG. 85.—Card Basket.

proceeds the points must be pulled upwards, and a crystal-headed pin stuck in each point to keep the winding intact. The last row of winding is of silver tinsel, and this is *twisted round* the pin each time and carried twice round from point to point to form a loop edge.

Any of the *reverse* patterns 1, 2, 3, 4, are suitable for this basket, but are not so pretty if wound in more than one or two colours. The basket is suitable to stand on a dressing-table, or it could be hung up as a novel picture frame.

A fancy handle of cardboard wound in cotton and tinsel can be added if desired.

No. IIIA.

Materials required.—1. Strutt's frame, star No. 2 or 3.
2. Strutt's Macramé twine, No. 10.

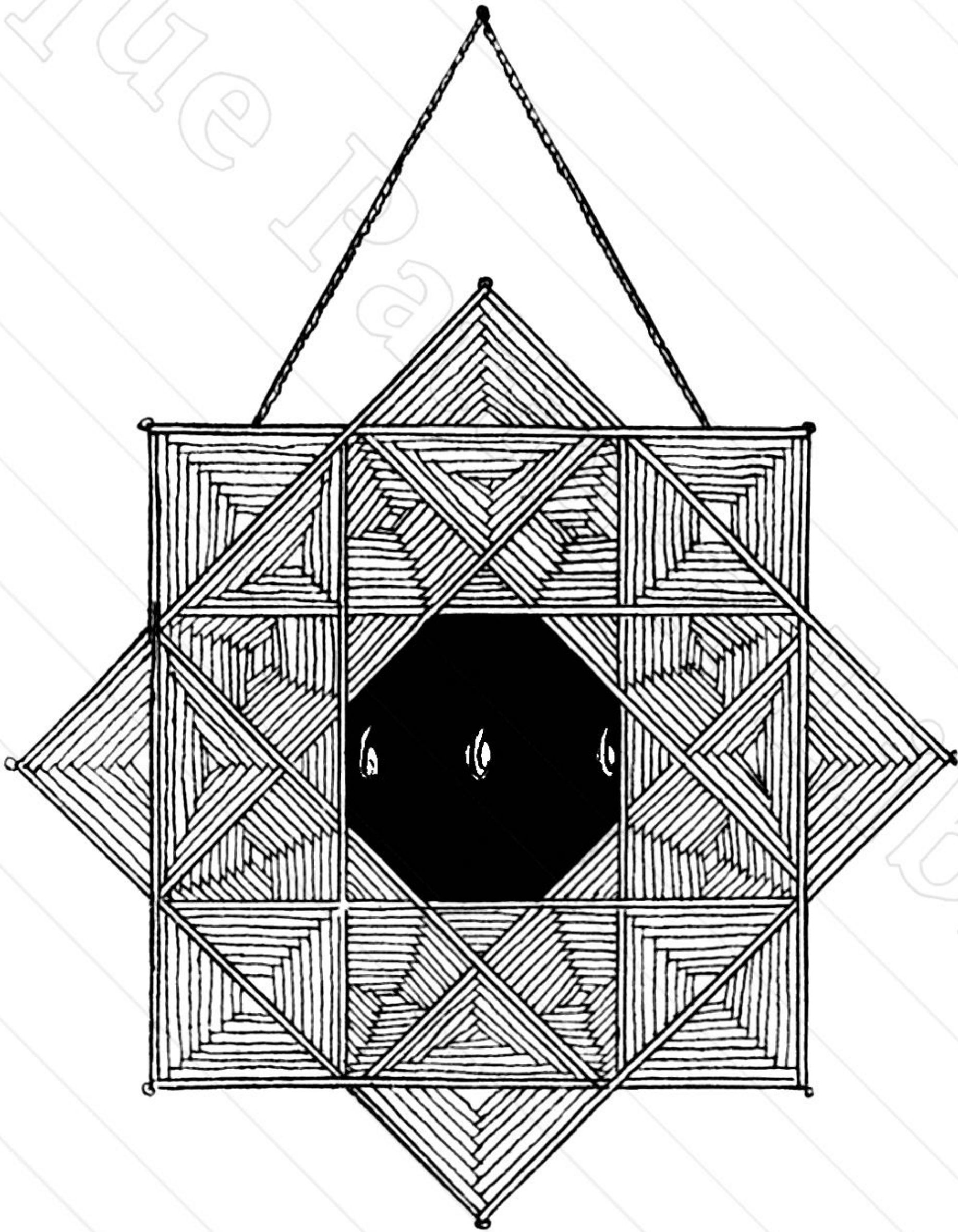

FIG. 86.—Key Rack.

3. Small square of plush and four hooks for the centre.
4. Brass-headed nails.

Method.—Examination of star, and use to which it is to be put. Paste velveteen or plush exactly in the centre of frame, and let it tone in colour with the string to be used.

The same section of frame is wound as in previous articles on photo frame and basket. Two colours are used,

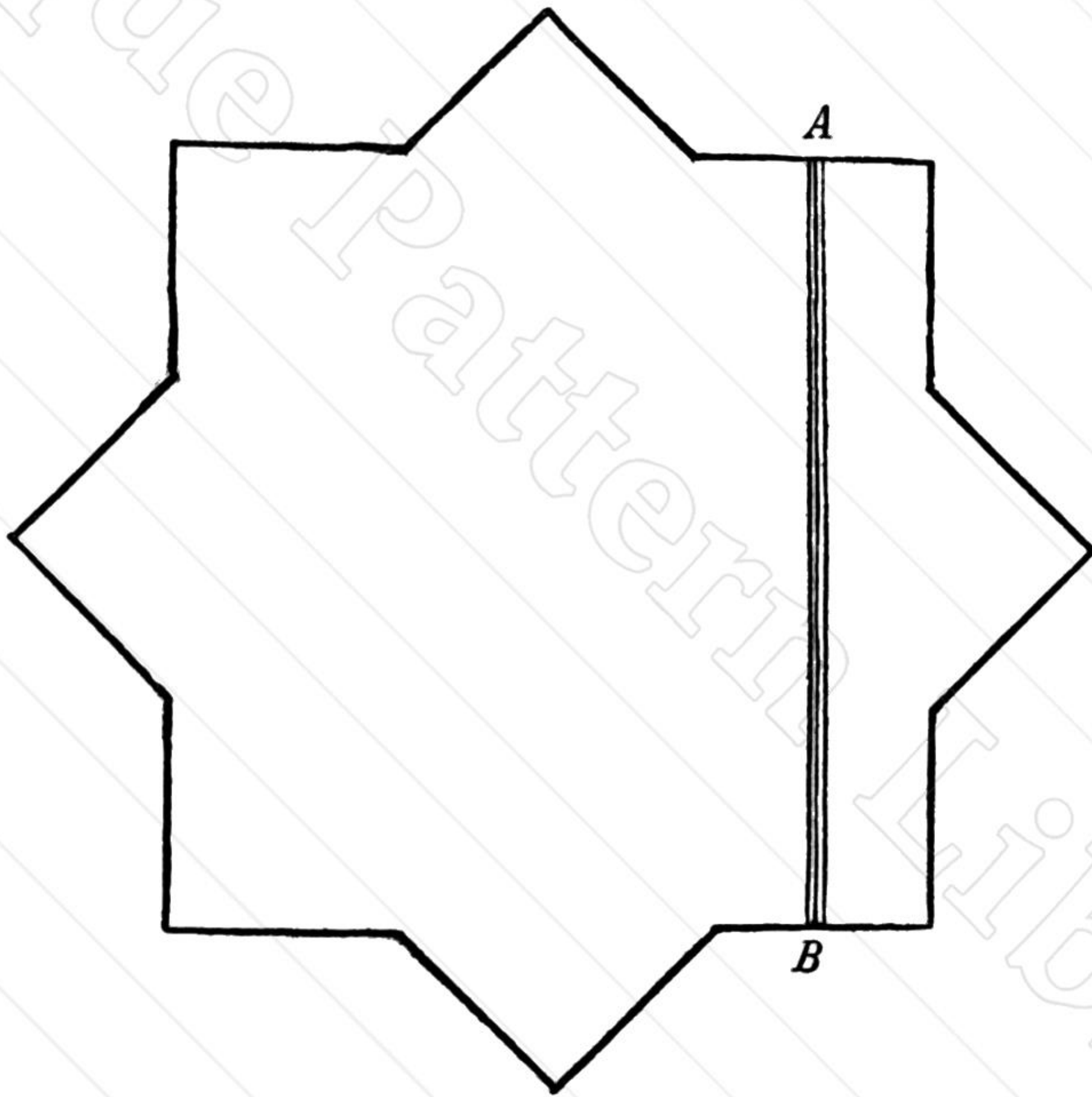

FIG. 87.

cream and brown, and an entire winding is done in each colour.

1. Take the brown string and begin to wind in the *middle* of the side, equidistant from the *point* and the *corner*, wind *four* threads, turn star, and repeat winding *four* brown threads exactly in the centre of each successive section round the card.

FRAME WEAVING

95

2. A complete round of brown is now succeeded by the cream string. Knot the new colour on at the back, and wind in same manner *four* threads of cream all round on the *right-hand* side of brown.

3. Two rounds, one brown and one cream, are now on the star. Continue with the cream string and wind four threads all round on the *left* side of the brown.

4. The star is completed by winding brown again right and left of the cream, and

5. Again by winding cream right and left of the brown.

6. Continue with similar bands until the frame is complete.

The pattern is very effective, and is low in the centre of each side, and rises towards the corners and points. If worked in two coloured browns, or cream and brown, it has much the appearance of carved wood. Screw in four hooks for keys, and attach plaited cord of same coloured strings to back to suspend the frame.

A variety of effects in this pattern may be obtained by using different colours.

No. IV.—PICTURE FRAME

Materials required.—1. Belper frame No. 10, or star frame No. 3.

2. Strutt's Macramé twine, No. 10.

3. Brass-headed nails.

This is a very effective pattern, and looks well in shaded strings, beginning with the dark and graduating to the light. Or if the worker will remember that the pattern is a series of diamonds, and that the *first three* windings form the centre spot of each diamond, it will then be easy to determine upon the colours. The diamonds are depressed

in the centre, and each successive winding of string forms a frame round the centre spot.

Centre.—The landscape and the glass to cover the centre must first be secured to the frame.

1. Wind the twine three times round the frame, commencing close to the corner, at 1. Complete the other seven sides.

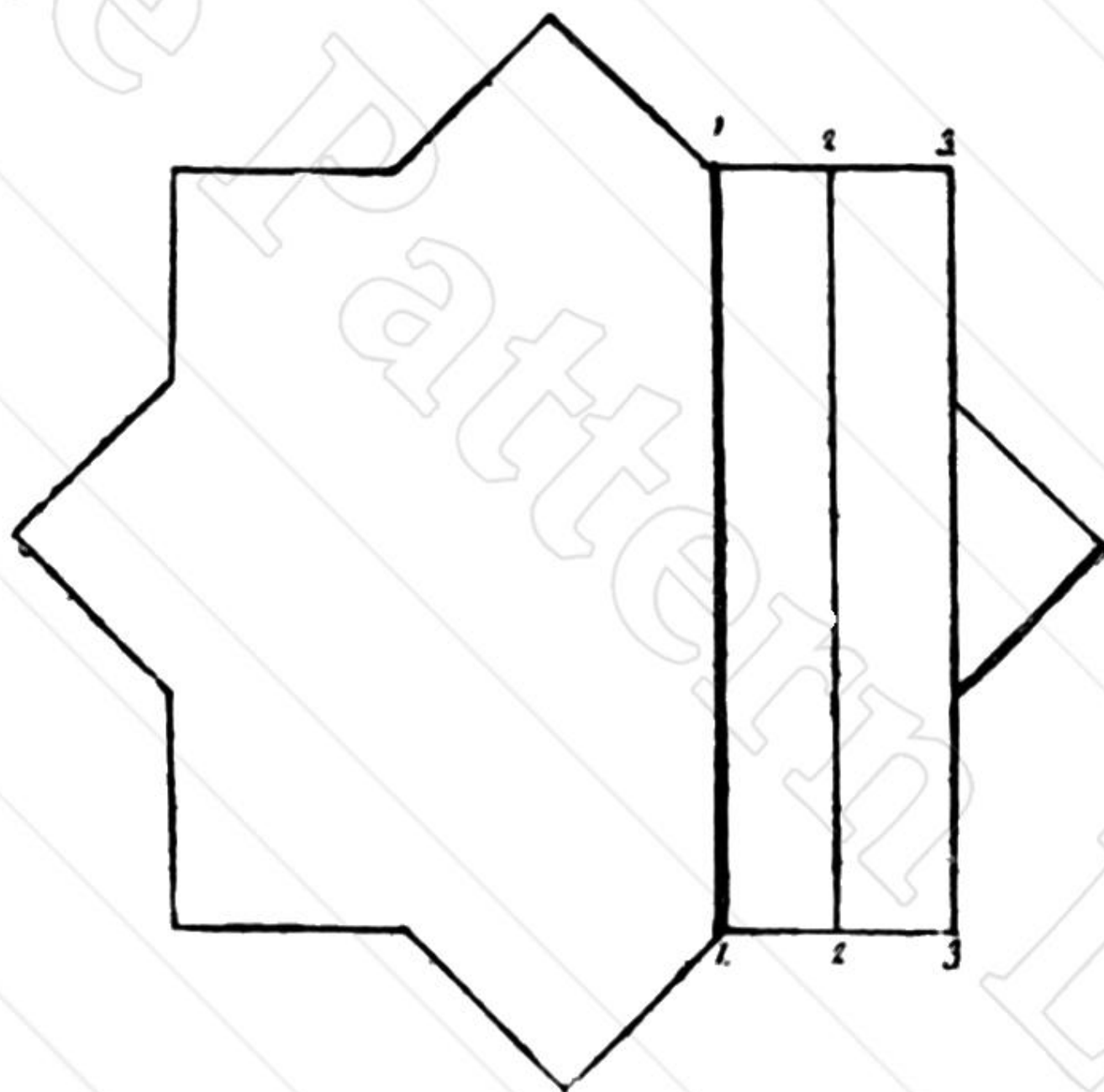

FIG. 88.

2. Wind round again at 2 in the same way, and with the same colour, and complete the other seven sides.

3. Wind round again at 3 in the same way, and with the same colour, and complete the other seven sides. These three windings will form the depressed centres of the diamonds.

The twine may now be cut off and another colour joined on, and proceed to wind three threads again at 1, and three threads at 3, as before. Follow this by winding three rounds on each side of the middle set, 2. Repeat on the other seven sides of frame, and continue same process of

FRAME WEAVING

winding at 1 and 3, and either side of 2 until the frame is complete.

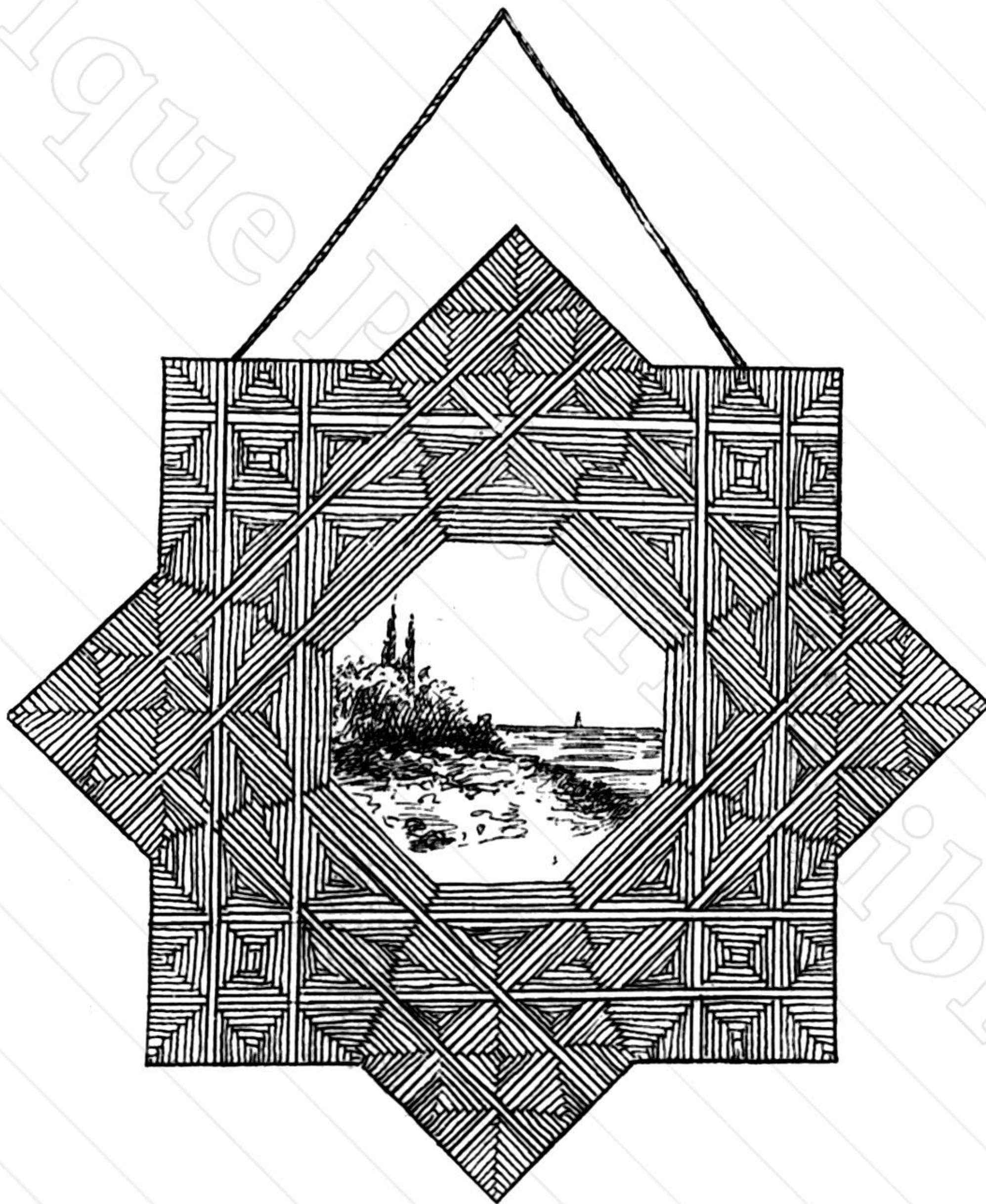

FIG. 89.—Picture Frame.

The last windings form a raised pattern, and make a very pretty frame.

A fresh shade of twine may be used for each round of the frame if desired.

H

Any of the patterns described for stars 1, 2, and 3 are also suitable for the Belper frame.

The Belper frame is a square combined with a rhomboid, and oblong in shape, and suitable for photographs and oblong pictures.

Patterns for stars and Belper frames may be summarised briefly thus—

1. Begin at *corners* and wind towards points.
2. Begin at *points* and wind towards corners.
3. Begin at *centre* and wind right and left of centre to corners and points.
4. Begin at corners, centre and points, and wind right and left till complete.

The same section of three points is used throughout for both frames.

The Sun Frame.—This frame has sixteen points, eight small and eight large.

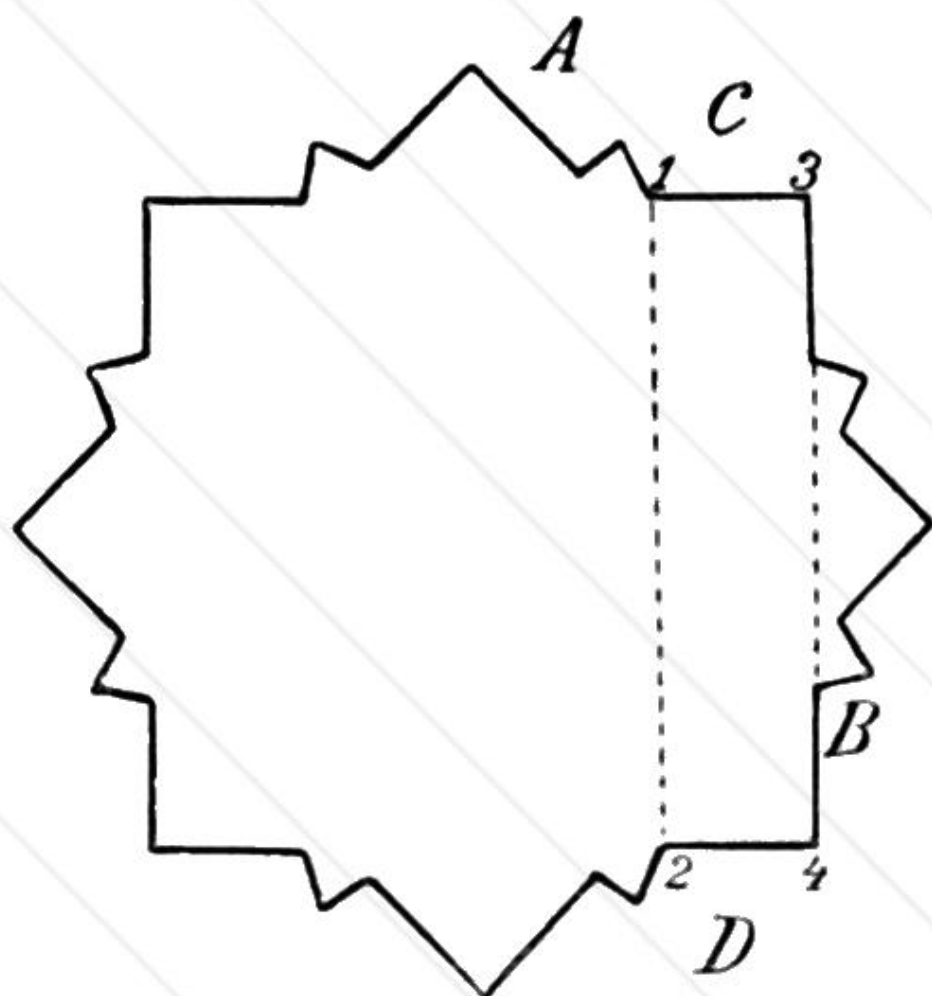

FIG. 90.

First attach the picture or photo for the centre, and wind six times round the small points from A to B. The first thread must lie close to the outside of the points, and gradually fill inwards. Repeat this winding of six threads on each of the other small points. Having done this, cut the

twine and tie another colour to it and proceed to wind another six threads from A to B, and on each of the other seven small points as before. Continue in the same way till the small points are full.

To wind the large points any of the patterns described

FRAME WEAVING

99

for the star and Belper frames are suitable. A good pattern for this part is the following:—

Wind three times round the section C—D, commencing close to the corner where marked 1—2; then take the thread to the outer edge of points and wind three times where marked 3—4. This should be repeated on the other seven sides. Now cut off the twine and tie another colour to it, and proceed to wind three times again from 1—2 and again from 3—4, and wind on the remaining seven points in the same way. Complete the frame by repeating the process till sides are full.

Second Pattern.—Another way of winding this frame is by beginning in the corner of the small angles and winding three threads, then in the corner of the adjoining large angles, then the small, and so winding round the star till the small angles are covered and the large half-full. Finish by winding the large angles only, as in preceding pattern. Immediately the small points are full add a brass-headed nail to keep string in position.

A PLAQUE

Materials required.—1. Strutt's circular cardboard frames.

2. Strutt's fine twine, No. 10.

3. Brass-headed nails.

4. A centre spray of flowers and glass.

Fig. 91 represents the largest circular star of thirty-two points. The centre consists of a tawny yellow card, upon which is laid a spray of yellow and white Marguerites and leaves, which was cut from one of the penny coloured text-cards by a child of six years in the paper-cutting class. A 12-inch square of glass is placed over the spray and

secured with string to the cardboard frame. The prominent tints of the picture are tawny yellow and green; these two colours are chosen for the winding, and are used

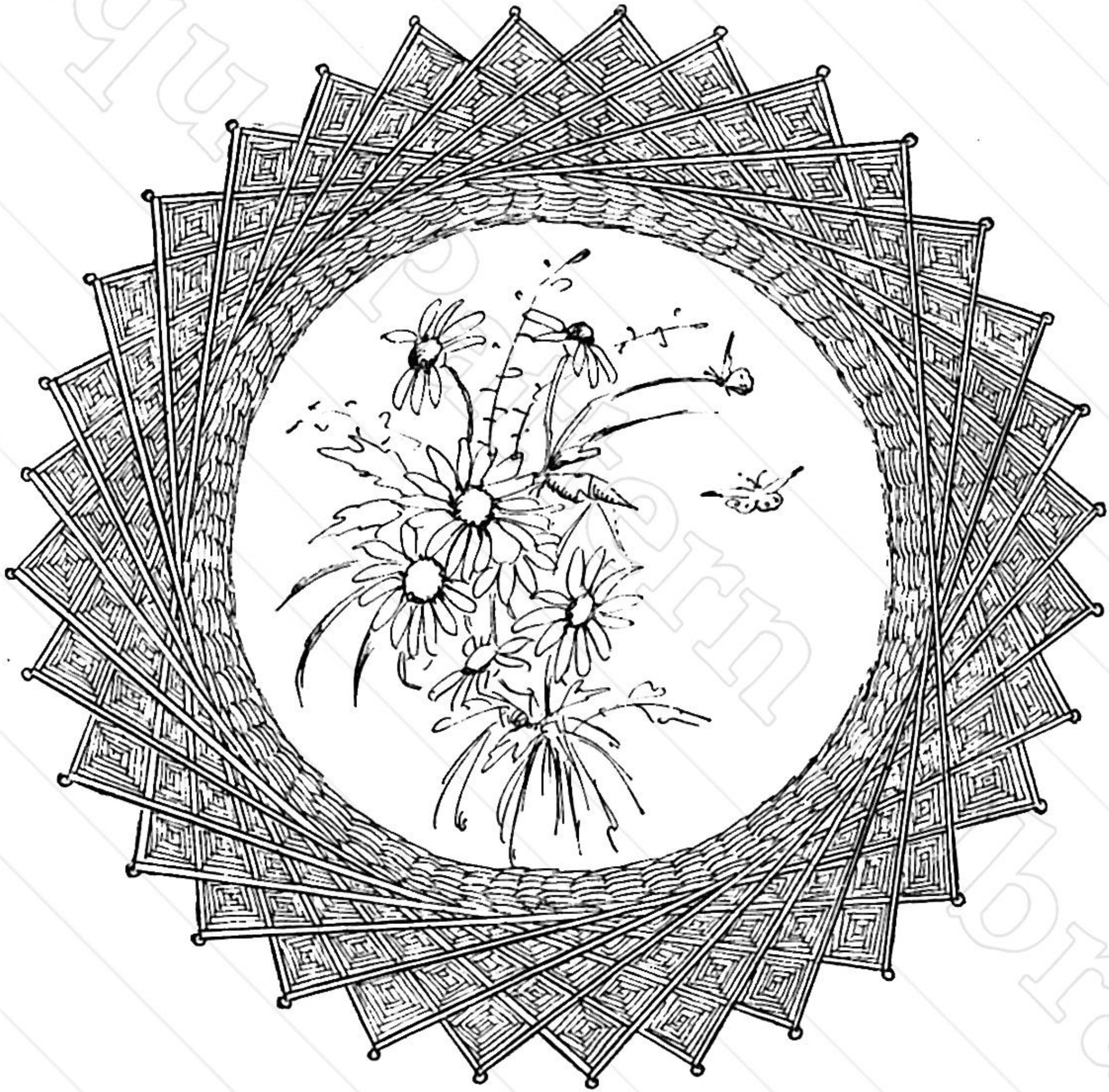

FIG. 91.—A Plaque. Finished Sketch.

alternately. The rule of dividing the points by four acts perfectly in this case— $\frac{3}{4} \cdot 2 = 8 + 1 = 9$.

Take nine points in every wind, step-wise round the star. Begin in the angle, wind three threads round No. 1 and No. 9 angles, turn star, move down one point, and wind three threads round No. 2 and No. 10 angles, and so on all

FRAME WEAVING

round till one band is complete. Cut off and join on second colour, and wind round in same manner close to the last weaving. Continue to use the alternate colours until the extreme points are reached. Secure the string with brass-headed nails, and finish off at back.

The pattern is started from the angle and worked outwards ; it therefore has a low centre and raised frame. The successive winds form a very pretty round centre.

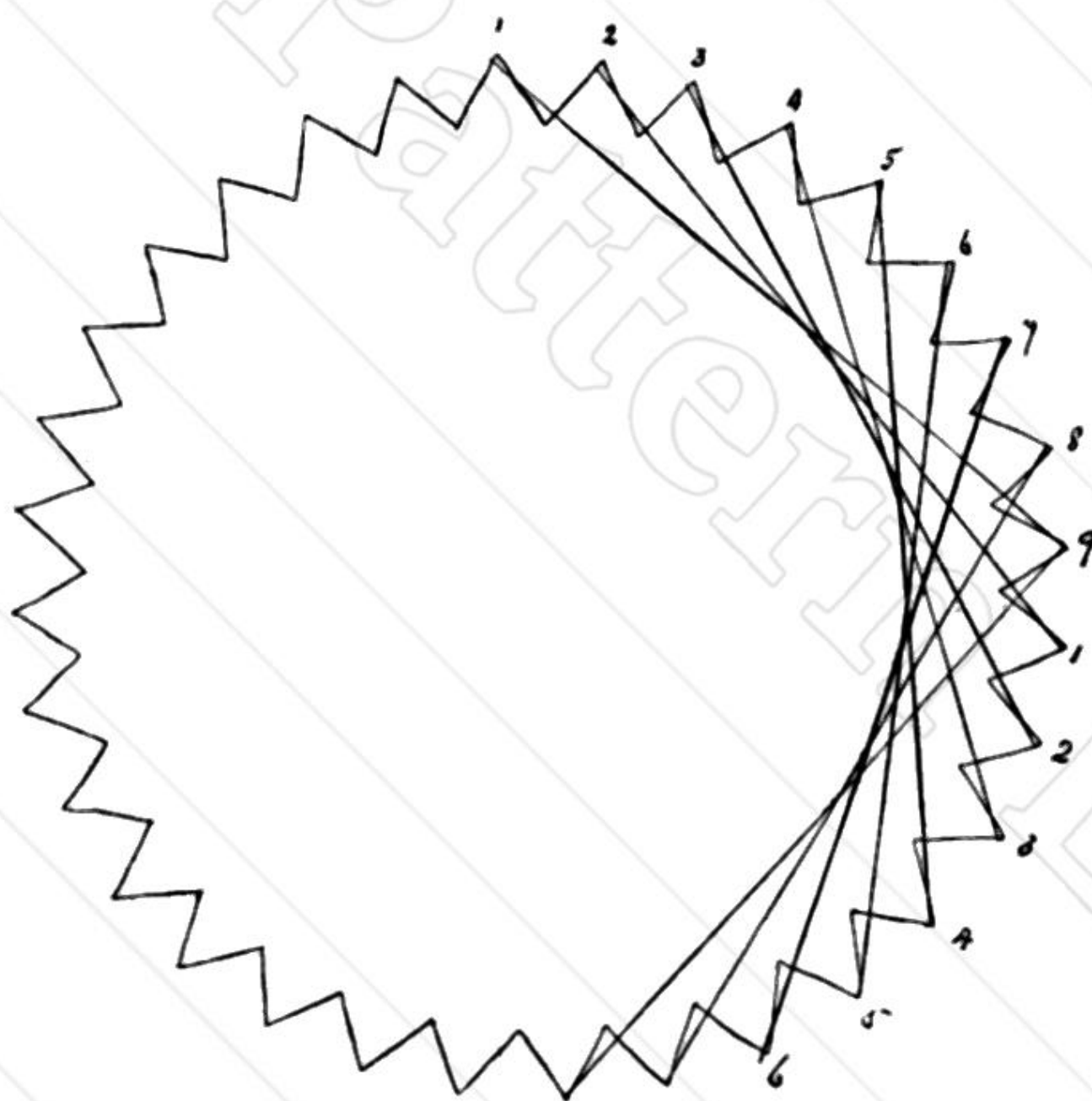

FIG. 92.

The opposite effect would be produced by starting at the points, but not with so good results.

These frames are useful for mounting any good hand-work.

Great care needs to be taken in the choice of colours. A wise rule is to wind with strings in harmony with centre.

The plaque is improved and shown to advantage if mounted on a larger circle of cardboard, covered with velveteen or plush.

When finished it is quite a work of art, and fit for any sitting-room, and yet can be entirely managed by an average child of six or seven years.

The border is narrowed or widened according to the number of points taken in winding. If a *less* number than nine points be taken the border will be narrow and the centre larger, and if *more* than nine points be taken the border will be wider and the centre smaller. A teacher must judge how many points to enclose to suit the size of the centre chosen. Small circular cards for practice might be cut in thin cardboard and wound in cotton.

STRING WEAVING ON CANE

Materials required.—1. Split cane, No. 1.
2. Macramé string.

Occupation.—This occupation is a very good exercise to precede the ordinary cane weaving, now so common in our schools. The children master the new difficulty of weaving a round object by not having unmanageable cane to encounter at the time. The centre foundation represents the Kindergarden tight mat, and the continuous weaving thread represents the loose strips. The pliability of the string renders the weaving much easier for the children to manage than starting with cane from the first.

Method of Teaching.—*To Make a Small Round Mat.*—Supply each child with eight strands of cane about eight inches long, and a small ball of string two or three yards in length.

1. Lay four strands transversely upon the other four to form a cross, A, B, C, D.

STRING WEAVING ON CANE

103

2. Hold the centre firmly between the thumb and finger of left hand.

3. With a strand of fine *cane* in right hand, leave an end E, and hold under left thumb.

4. (a) Cross diagonally the centre ; (b) back *under* set of A strands ; (c) cross centre diagonally ; (d) pass under set of B strands.

This crossing will secure the strands, and the cane must be pulled quite tight to form a compact centre. Consider

2.

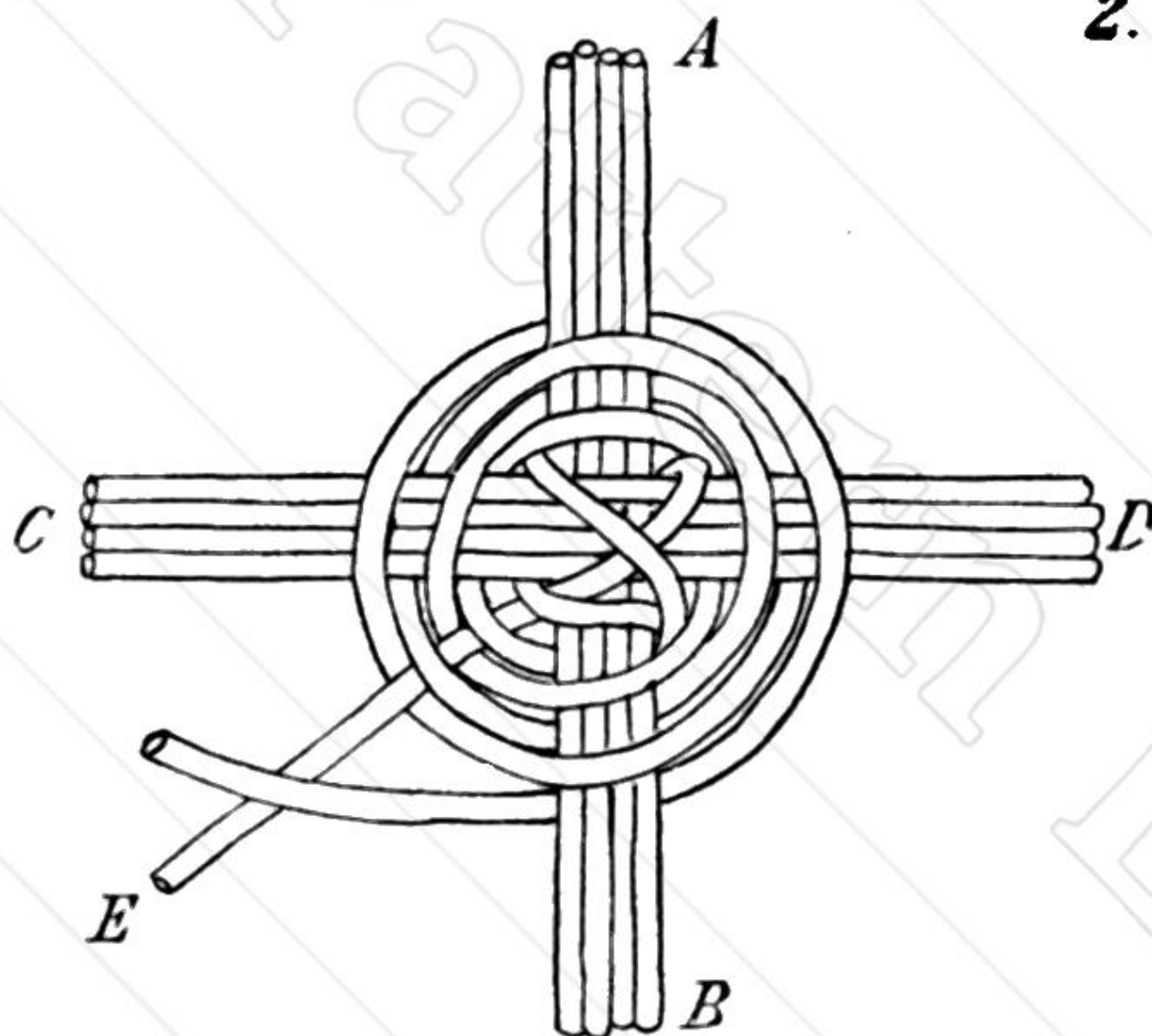

FIG. 93.

the *single end* as a set of four, and weave over and under for about three rounds. It is necessary to have an *uneven* number of strands for circular weaving, to make the weaving alternate properly.

It is best for a teacher to get her centres ready made for the first few lessons, after which each child might attempt to begin for himself.

The sets of strands A, B, C, D, are next to be divided, and the single end E still treated as a *set*, this time as *two*. Begin on with the end of string, and weave two over and

two under for about six rounds, keeping the string tight and the rounds close together.

This done, divide the "twos" into "ones," and weave

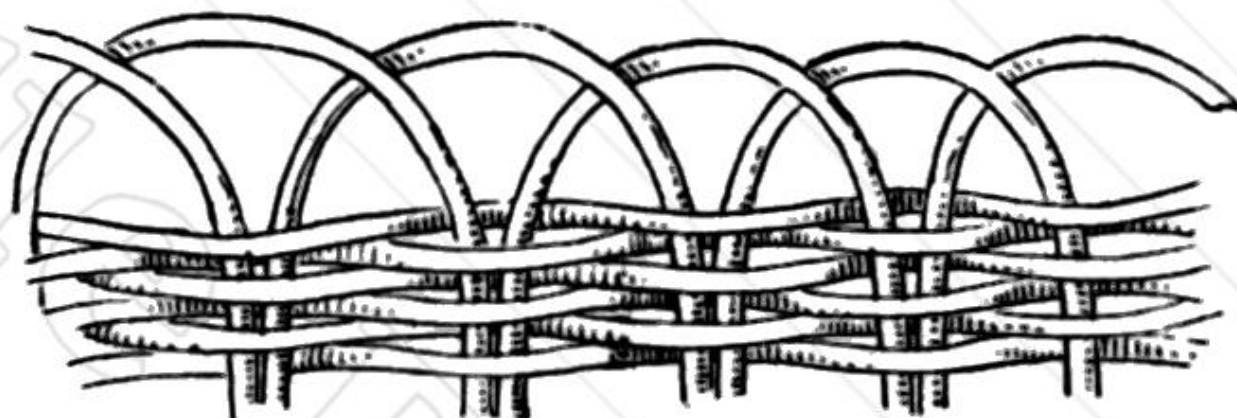

FIG. 94.—Border.

another six or more rows until the mat is about three inches in diameter.

Border.—1. Cut all the strands of equal length.

2. Take any one strand, pass it *behind* the *next*, and down by the side of the second.

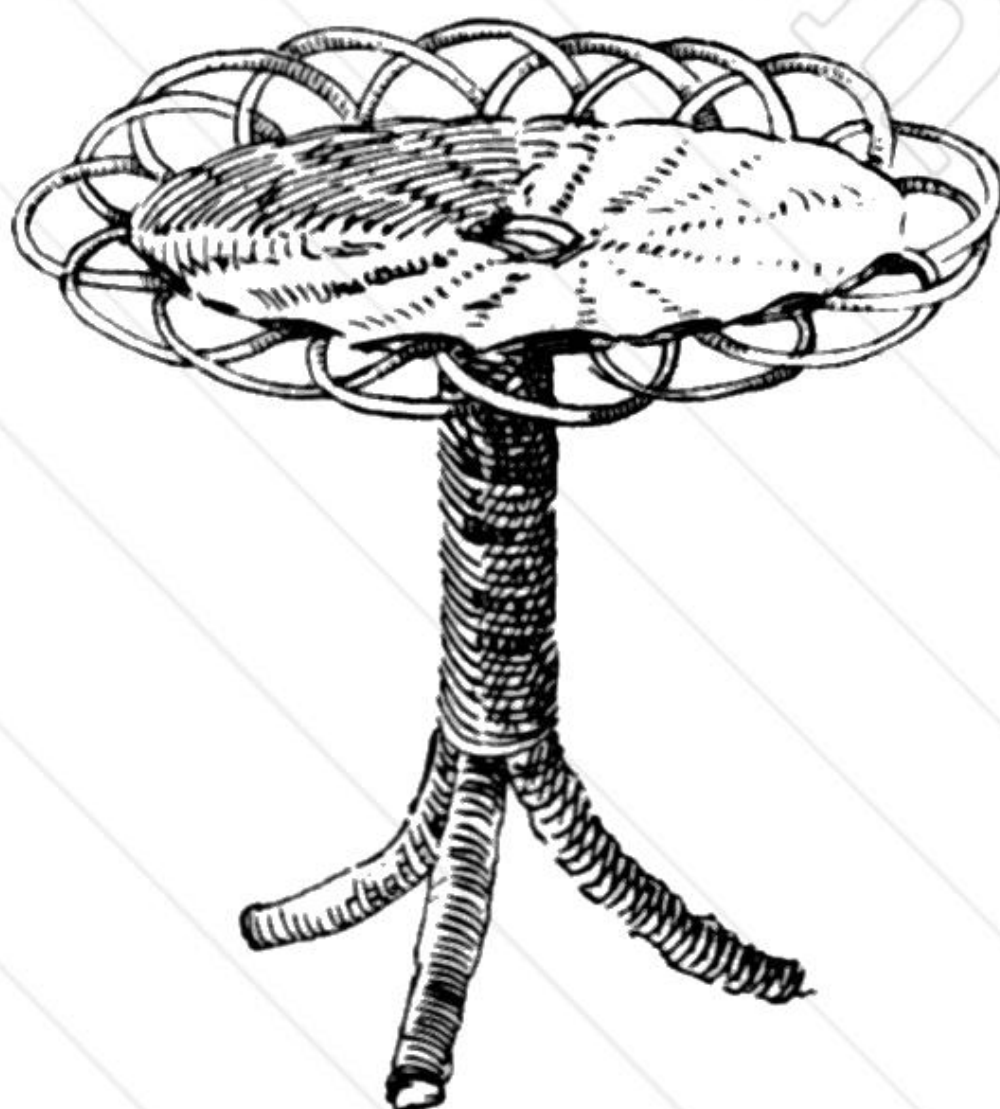

FIG. 95.—Table.

By first inserting a knitting needle no difficulty will be found in threading down the ends into the weaving.

Table.—Weave a mat of 4 inches diameter, according to

preceding directions, with strands of cane 12 inches long for the top.

Pedestal.—Push the ends of strands of border into weaving as far as the *cane* centre, drawing them down on the under side to form the pedestal of table. Take *all* the strands and bind together, winding them with string to within an inch of the bottom.



FIG. 96.—Chair.

Claw.—Divide the strands equally into three sets, and wind each set with string to form the three claws of pedestal.

Chair.—This is made very similarly to the table. Weave a small mat, and bring the ends of strands out underneath, a few rows from the border. Divide these into four sets, and wind each set with string to form the four legs.

Round Back.—Weave a similar circle for the back, and leave three or four adjoining strands unfinished in the border. These must be interwoven into the under-side of seat, to join the seat and back together. The circle must be bent upright to form the back.

Straight Back.—The straight back, as shown in Fig. 96, is made by inserting four or more consecutive upright strands into the seat, and weaving backwards and forwards. The ends are pinched and pushed down to the *bottom* of the back to give firmness and strength to the weaving.

The lesson should be made interesting by talking of the colour of string—of what made, and how made—the cane, how obtained, etc. The articles to be made should also form an object lesson upon “tables and chairs,” etc.

Baskets, partly made of cane and string, are very pretty, and can easily be made from the same instructions given in cane weaving.

WEAVING WITH MACRAMÉ TWINE

Small articles look better and more artistic when woven with the fine Macramé twine.

The colours are very beautiful, of forty different shades, and may be purchased retail in $\frac{1}{4}$ -lb. balls, or wholesale in 3-lb. packets.

The weaving is very fine, and therefore the number of strands required for the foundation are twice as many as those used with No. 4 string, otherwise the plan of weaving the mat is exactly the same.

Materials required.—1. Fine split cane, No. 0 or 1.
2. Fine Macramé twine.

Preparation by Teacher.—1. Cut the cane in

WEAVING WITH MACRAMÉ TWINE

107

lengths of 12 inches, allowing sixteen lengths for each child.

2. Lay eight strands horizontally, and the other eight transversely to form a four-armed cross.

3. Hold the centre firmly between left thumb and finger,

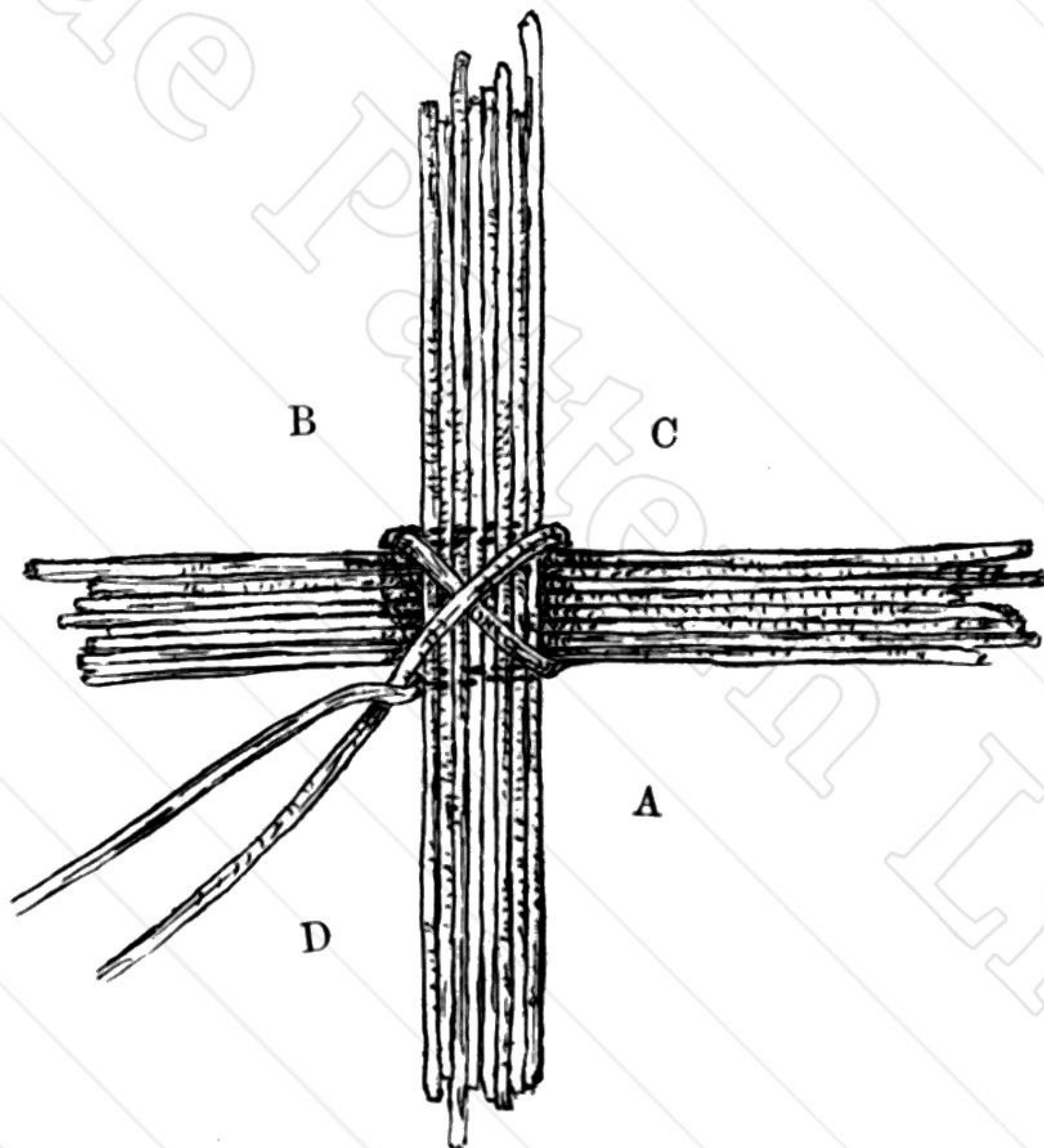

FIG. 97.

and with another strand 14 inches long secure the centre thus—

4. *Under D to A.* Cross over from A to B diagonally. *Under top set to C.* Cross diagonally C to D. Twist cane to first end, and treat as a pair. Wind end of string, or tie to this pair, and begin to weave at once, two over and two under. There are *nine* pairs including the binding strands, and this will allow the weaving to alternate

correctly, and there will be no need to insert odd rays. As children find the foundations rather difficult to manage, it is far better for a teacher, or the sharp children, to prepare the cane centres before the lesson, so that all the class can work together and follow the directions given by the teacher from time to time. It is wonderful what can be taught well if a little preparation is made, and the class kept at exactly the same work.

ROUND MAT

The Object to be Made.—A round flat mat, about four or five inches in diameter.

Supply each child with a ready-made centre and string attached. Begin by weaving two over and two under, and continue until the mat is 3 inches in diameter. See that the rays are spread evenly, and make a good shaped circle. The teacher must, from time to time, examine the work, and pull the rays in place. When the centre is 3 inches across cut off *one* strand, leaving thirty-three rays. Immediately *after* the *single* strand, begin to separate the pairs into “ones” and weave about half an inch more all round in this way.

Border.—Pass the end of twine into weaving for security, and proceed to finish the ends of cane.

Cut all the spokes equal in length. Hold the mat vertically, and take any ray, pass it behind the next, and push the end down into the weaving, close by the side of the second ray from it. Continue this process until all the rays have been treated in the same manner.

The article, finished, should present a very delicate and pretty mat, which may be adapted to the following uses :—

1. *Pin-cushion*.—Cut a round of cardboard, about two inches in diameter, and place a wedge of wool, wadding, or frayings, on the top, securing it to cardboard by a few stitches.

Next cut a circle of velvet or satin about four inches in

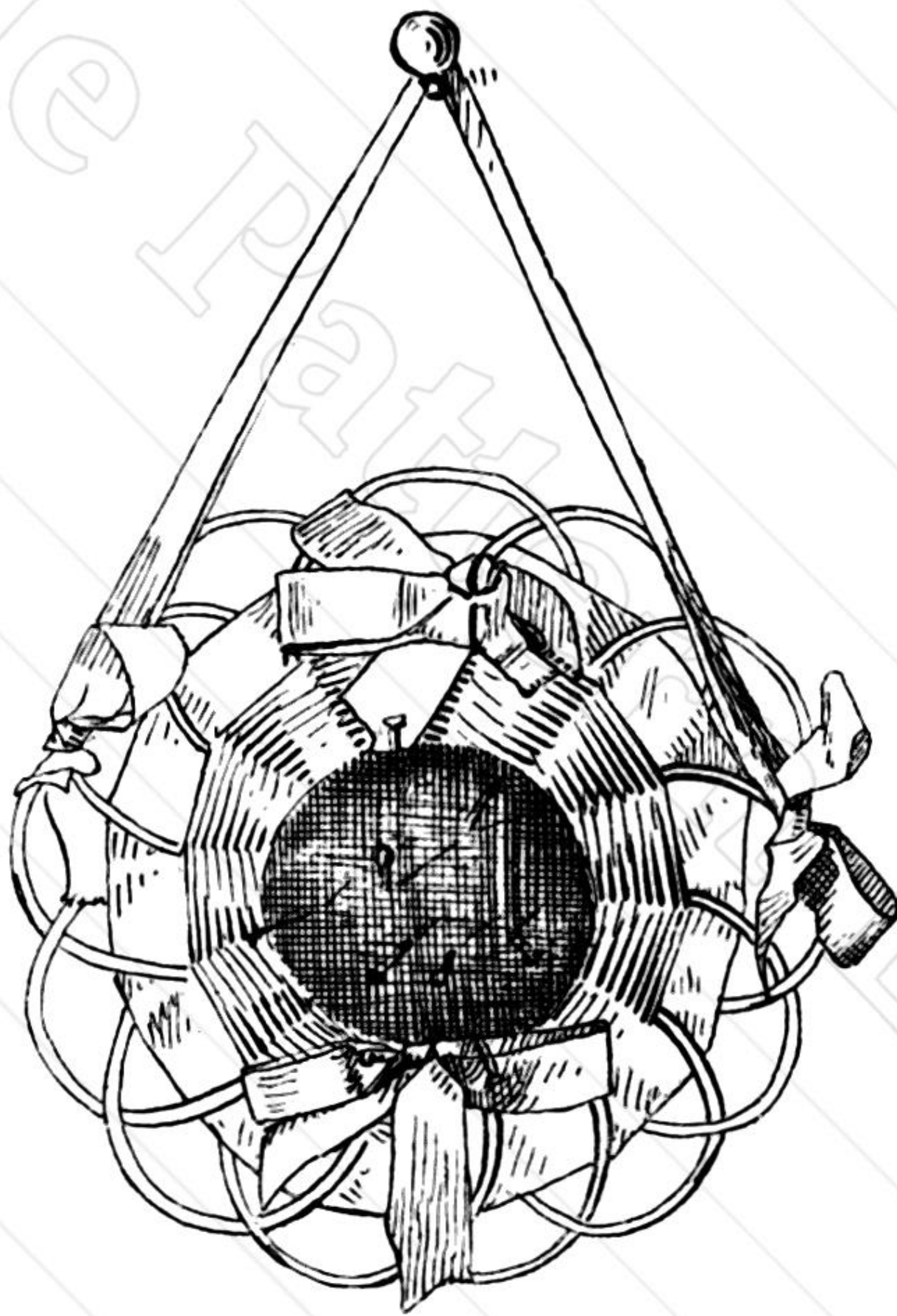

FIG. 98.—Pin-cushion.

diameter. Gather the edge rather coarsely with thread, place inside the wool and cardboard, and draw up tightly and fasten off. Sew the cushion *exactly* in the centre of mat.

Fig. 98 represents a mat woven with biscuit-colour string and a crimson plush cushion. The border of mat is interlaced with crimson satin ribbon $\frac{1}{2}$ inch wide. The

pin-cushion may be suspended, if desired, or used flat on the table.

2. *Needle-book.*—Two of the mats may be used as covers for a needle-book. They need no lining, as the

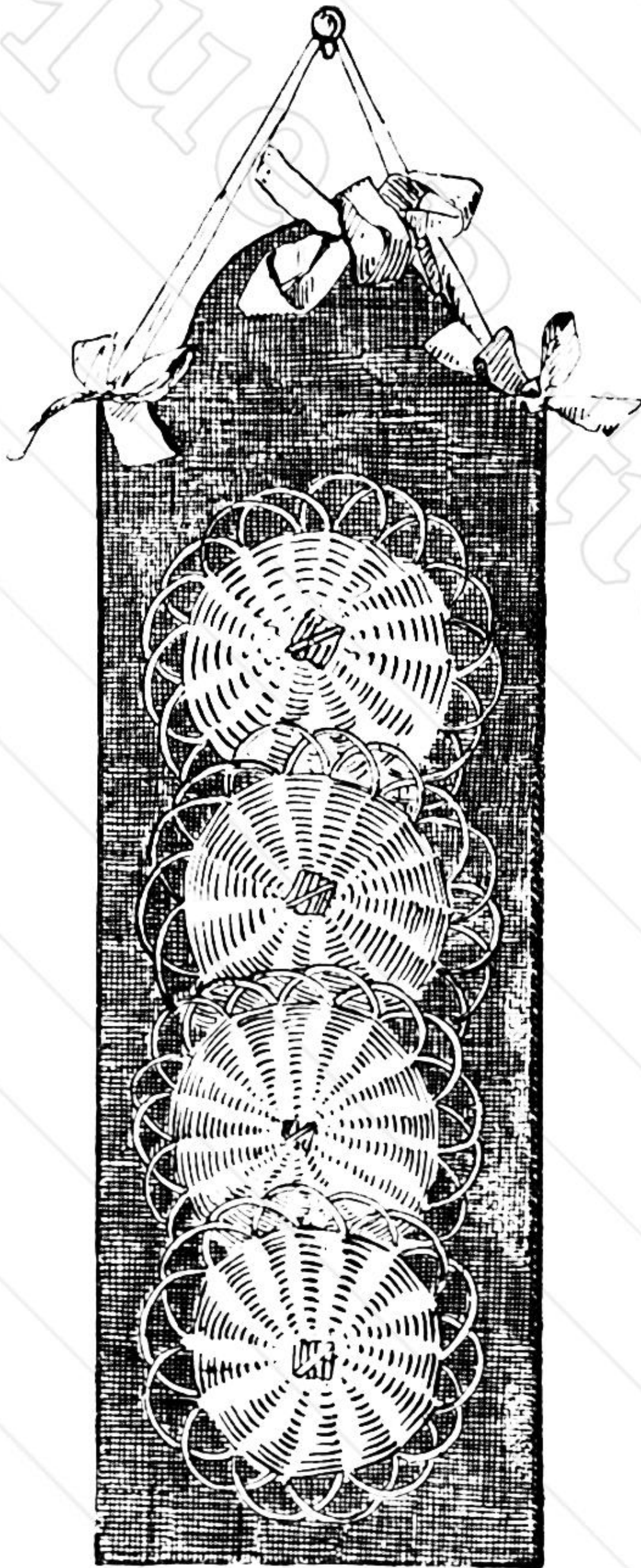

FIG. 99.—Letter Rack.

work, if nicely done, will look well either side. Cut three or four circles of coloured flannel the size of centre of mat, pink, red, white, or blue, whichever harmonises best with the colour of the twine. Snip the edges all round, and insert them between the two mats. Sew the backs together, and ornament with bows of ribbon.

3. *Letter Rack.*—Four or more mats may be used for this article.

Fig. 99 represents a cardboard foundation covered with peacock blue velveteen, and four mats woven in old gold Macramé twine.

Cut the foundation in stout cardboard, about sixteen inches long and six inches wide. Shape

SINGLE STRAND CHAIR-CANING

111

Next sew on the mats, securing them only at the bottom. Allow the next mat to overlap, to hide the stitches, or add a bow of ribbon at the bottom of each mat instead. Cover the back with sateen, and slip-stitch to the edge of velveteen, or paste on a leather-paper back for neatness. Finish the top with bow and ends of ribbon.

4. *Candle Shade*.—Fasten a brass candle-clip to a mat in the following way:—Insert the *hook* of the clip into the weaving *at the border*—not the *centre*—and fasten with a few stitches. A pair of these candle shades will be found useful and artistic for piano candles.

Of course, the colours should be carefully chosen.

Note.—The directions here given for making mat are suitable for other materials, such as wool, ribbon, cane, etc.

5. *Card Basket*.—Tie six mats together with bows of ribbon and take one a little larger and tie in for the bottom and to the borders of the six small ones.

SINGLE STRAND CHAIR-CANING

Introduction.—For this occupation the slates which are condemned as useless are broken up, and the frames utilised in the following way:—

They are first cleaned by the boys with a piece of sand-paper. This little performance forms a pleasant pastime for one afternoon, when each boy will vie with his neighbour to get the greatest smoothness and best gloss and colour.

The next step is to drill holes. These must be about a quarter of an inch in diameter and placed about three-quarters of an inch apart.

The little boys were given a trial to do this part of the work with small gimlets, but the result was not satisfactory, for the following reasons :—The wood was hard and cross-grained, and split if not judiciously managed, and many of the boys were too weak in the wrist to make much progress. The best plan is to have all the slates uniformly drilled by a carpenter with a $\frac{1}{4}$ -inch stock and bit.

The holes must be drilled to correspond exactly on opposite sides, and one hole must be made in each corner for the diagonal weaving.

Each boy must have his own “pegger.” This is a little peg to wedge into the holes and keep the cane from slipping after it has been tightly strained into position. Each boy will readily bring his own, made from a piece of firewood ; or, if the small signal pointers used for reading be in use in the school, they answer admirably and look much nicer for class use than the rough pegs.

The cane used is bought in pound bundles, and one bundle will last a long time. It varies in price according to size, from 1s. to 1s. 4d. per pound. The sizes 1, 2, and 3 are most useful, and Nos. 4 and 5, being wider, are best for beadings.

Preparation.—Soak the cane for one or two hours before using, it will then be found soft and pliable, and each length of cane must be drawn sharply across the blade of a knife, to get rid of all superfluous, pithy matter, and leave the cane *thin, pliable, and soft*. To do this quickly, place a piece of felt or leather or carpet across your knee, and, holding the knife firmly upon the pithy side of the cane, draw the cane sharply under it with the

SINGLE STRAND CHAIR-CANING

113

left hand, when all uneven pieces will be scraped off and the cane become of uniform thickness. This little hint is the great secret of obtaining good chair-caning.

There are several difficulties to encounter, and these should not be presented all at one time, therefore the easy method of single strand chair-caning, the one in common practice with ordinary street chair-caners, is first taken.

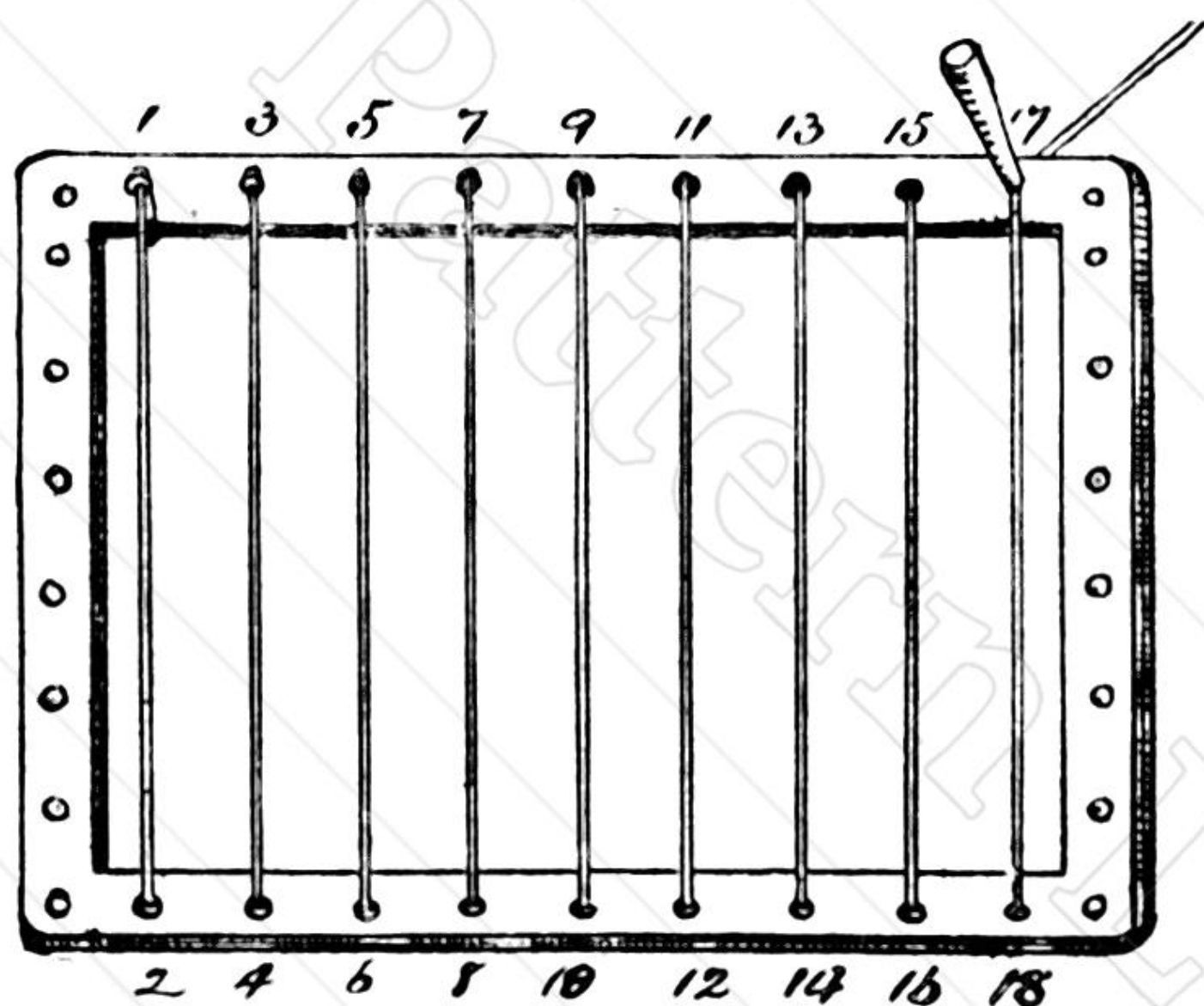

FIG. 100.

Method.—Give each boy a drilled slate, pegger, and a length of cane (scraped and wet).

To begin, pass the end (glazed side uppermost) *down* top corner hole No. 1, and pull the end forward underneath, and pass *down* through the hole again. Pull tightly and the wet cane will cling to the frame of the slate and make a firm beginning.

The cane being soft and pliable will cling round the frame; the long end must be pulled thoroughly tight and the pegger placed in the hole; then the short end is cut off

I

close to the frame. No unsightly knots or ends should be permitted at the back of the work.

The weaving is carried on on one side of the slate only, the glazed side of the cane must always be uppermost, and to secure this uniformity the twist of the cane is managed when passing from hole to hole.

Weaving.—Pass cane across to opposite side of slate and thread *down* No. 2 and *up* through No. 4 on the same side; pull tightly and peg. Now cross over and pass *down* No. 3 hole and *up* through No. 5 hole; pull tightly and peg. Cross back again, and continue working two holes each side in this manner till all are done.

When a new strand of cane needs beginning on, it must be done in the following neat way:—Thread up the end of *last* strand through the next hole, as usual, and also thread up through the same hole the *new* strand, which must have the end turned with *one* single knot. Pull the new and old strands tightly up through the hole, and let the former lie upon the latter; place the pegger in the hole and cut off the old strand close to the frame. The end will never come out, and the back of the work is neat and free from unsightly twists and ends.

Crossing.—The sides of the slate are next to be treated in the same manner, and *at this stage* they are not to be woven but crossed from side to side upon the *top* of the first set of strands and pulled tight and pegged as before described.

If the strand of cane be long enough to continue on to the sides, thread the end across to first hole and proceed as before. Remember to avoid the corner holes; they are only used for the diagonal weaving.

Diagonal Weaving.—The children may probably have some knowledge of this kind of weaving if they have been

SINGLE STRAND CHAIR-CANING

115

taught upon paper mats. If not, it is very simple and easily understood by the children if explained in this way.

The weaving at this stage consists of a series of open

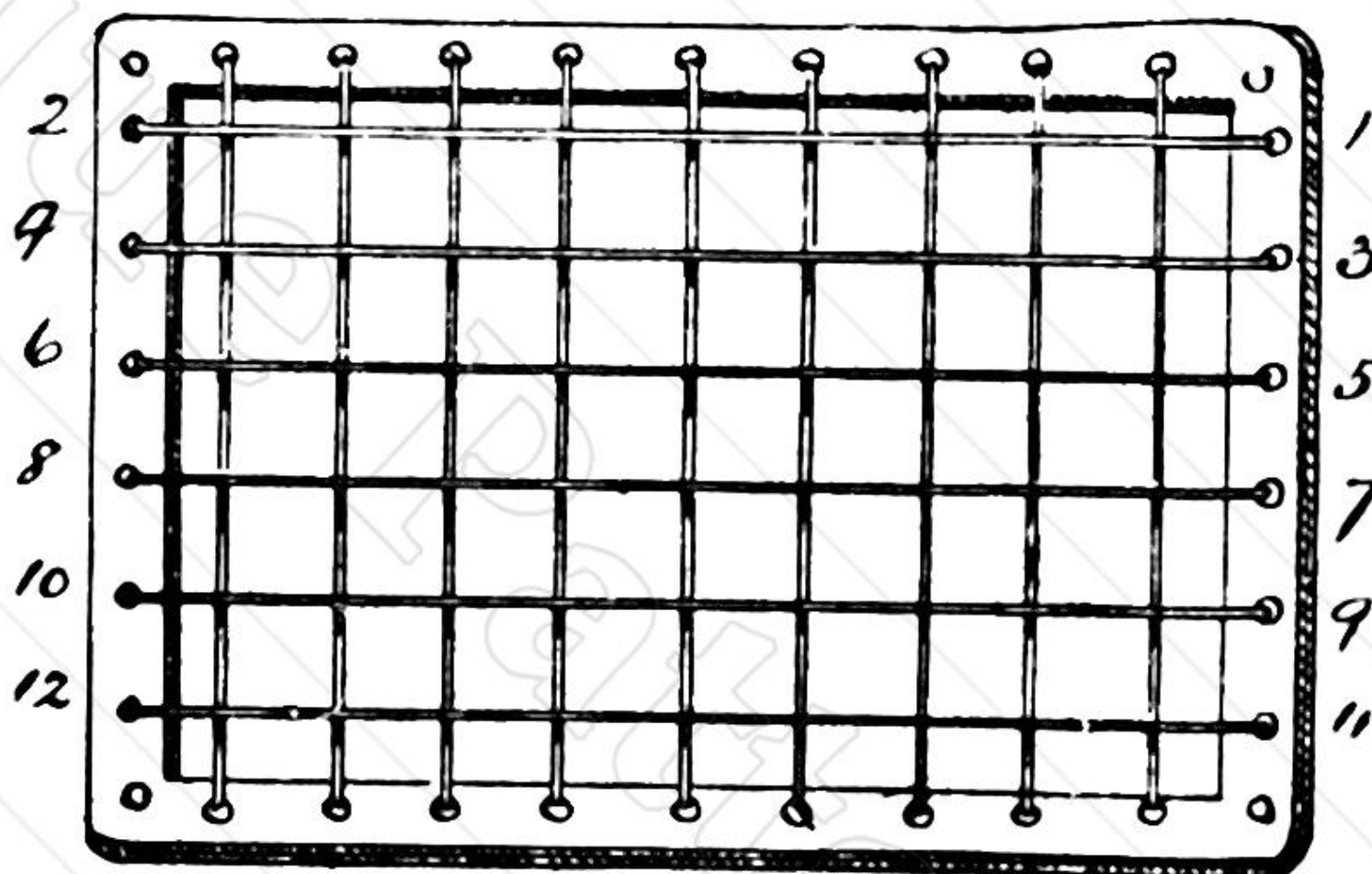

FIG. 101.

squares, composed of horizontal lines at *top* and vertical lines *underneath*. The rule of all weaving is to reverse the

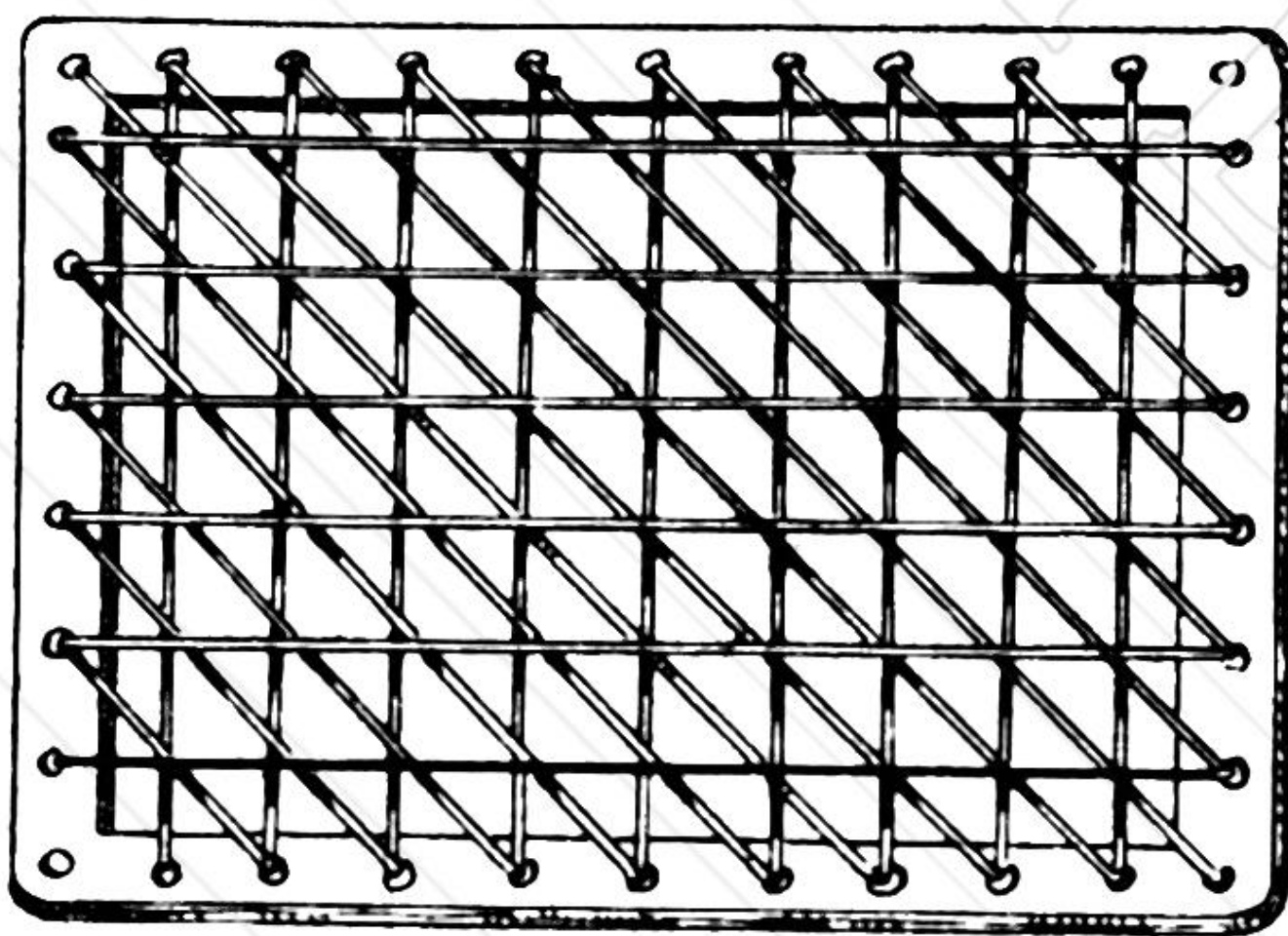

FIG. 102.

order of the last weaving, and the children will readily say that the upright or vertical strands must be lifted *up*, and the horizontal strands passed over or put *down*. See that the children understand the meaning of the word

“diagonal,” and illustrate what is meant and required on the blackboard.

All the children will have to remember is, “Lift up all the *standing up* strands,” threading from corner to corner. Begin at bottom right-hand corner and thread from corner to opposite corner. The strands for diagonals are cut in lengths and the ends passed down into the holes, where they are afterwards secured with wooden pegs.

In reversing, the diagonal weaving to go the opposite

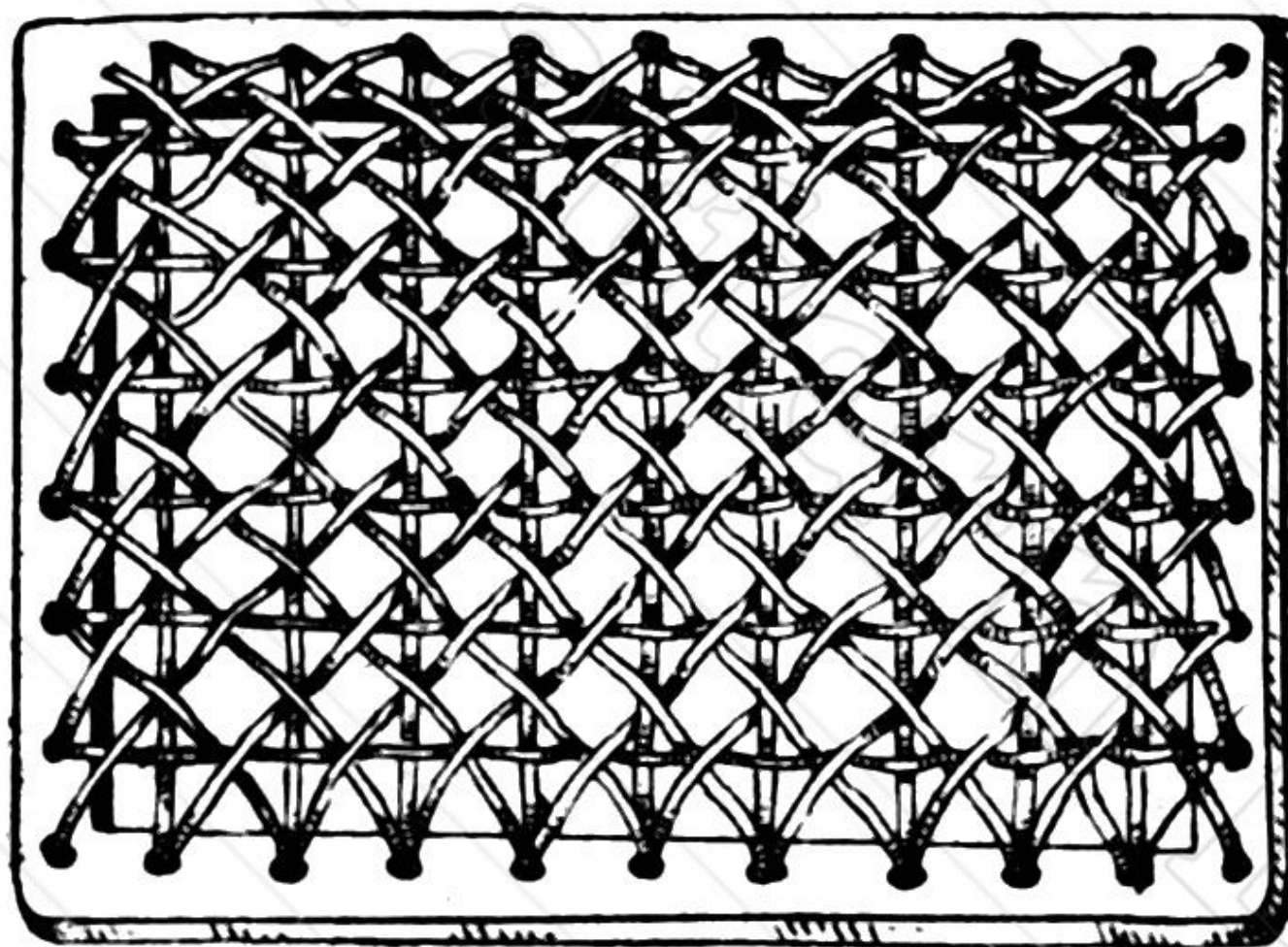

FIG. 103.

way, turn the slate round till the next empty corner is on the right hand, and proceed with the reverse diagonal. This will be just the opposite to the last process—all the horizontal lines will be lifted up and the verticals crossed over. Lead the children to see that their diagonals should cross each other on all the sides of the squares—one diagonal must be on *top* and the other cross on the *bottom*; if two diagonals *touch* each other the work is wrong, and must be undone.

Pegging.—If the holes be not too large, the ordinary bundles of Kindergarten sticks will do for pegging purposes,

SINGLE STRAND CHAIR-CANING

117

but the boys are ever ready with pocketsful of nicely sharpened little pegs for the purpose. In fact, they are so zealous in the pegging part that they will peg more than one would wish, and must be looked after. It is desirable only to let pegging be done to really satisfactory work, and this rule is a great incentive in producing carefulness. The Kindergarten sticks can be wedged and pushed in by the hand and cut off, but pegs for chairs must be cut a little larger than the hole, and knocked firmly in with a hammer, and then levelled with a sharp knife. Knives at 4d. each are supplied to the boys, and no accident has yet occurred in either scraping the cane or pegging, although the work has been in practice for three years.

The great advantages of the work are that it is inexpensive, useful, easily undone, and that common string can be used for teaching purposes until the whole method of weaving and pegging is thoroughly understood. The writer has used string for teaching purposes with great success.

Double strand chair-caning will be taught in next article.

Note.—As the slate frames are not perfectly square the diagonal will cross to the top hole on side and not to the corner hole, which would be the case if the slates were square and the holes equal. By turning slate with the long sides *vertical*, the *second* diagonal may be woven exactly according to the rules for the first, viz. “Lift up the ‘standing up’ strands.” If this method be adopted, it will be found simpler and easier for the children.

DOUBLE STRAND CHAIR-CANING

Materials required.— 1. Split cane, No. 3, for the transverse crossings, and No. 2, for the diagonal weaving.

2. A wooden pegger.

3. Sharp knife.

4. Firewood pegs.

5. Drilled slate frame.

Method.—The cane used for double strand chair-caning must be of finer quality than that used for single strand, or the work will be clumsy. The cane used for the diagonal weaving should always be a grade finer than that used for the first two crossings. The diagonal weaving is the most difficult to manage, and to do it successfully the cane should be thoroughly soaked and scraped *both* sides; this will remove all stiffness and render it so pliable that it can easily be pulled along into place as the weaving proceeds. The strands for diagonals should be measured and cut a little longer than required, so that the ends may be inserted in the holes of the frame, where they will be secured by wooden pegs. Always work the way of the grain of the cane and avoid faulty pieces, otherwise when straining the cane the weak place will give way, and much of the work may have to be done again in consequence.

Soak the cane for quite two hours before using, and scrape the rough side to remove all uneven pith.

Beginning.—Place slates lengthway on desk, and begin in top left-hand hole (No. 1, not the corner hole). Pass the end *down* through the hole and pull it forward inside frame, and thread *down* into the same hole, pull the long end tightly and cross over *down* into opposite hole (No. 2),

and *up* through the next on same side (No. 3). Cross back and *down* through No. 4 and *up* through No. 5, and so on.

The children will soon learn that the method employed is "down and up" on one side, "cross over," and "down and up" on the opposite side. The glazed side of cane must be kept uppermost, and the cane must lie flat when coming from the holes.

After the slate has been crossed once, the same process must be repeated again, threading the cane into the same holes. The best method is to complete the first crossing and pass the end up through an adjoining hole on the sides, and then begin again, either with a single tie-knot, or, as in first beginning, *in the last hole threaded*. The second weaving strand will be passed into the same holes as the first, and come out on opposite side of slate.

Crossing.—The slate when threaded double one way has now to be crossed. This crossing is woven, and must be worked with two strands, one coming from either side.

Thread a length of cane in the top hole on each side (not the corner hole), and with the right strand weave across, one over and one under, to the opposite side, and pass the strand down through the same hole that the other length proceeds from. Now take the left-hand length and weave across, reversing the weaving of the preceding row, and thread the end down through the hole of the first strand.

Pull each tightly across and peg. Keep the weaving close together to form little woven squares, as in Fig. 104.

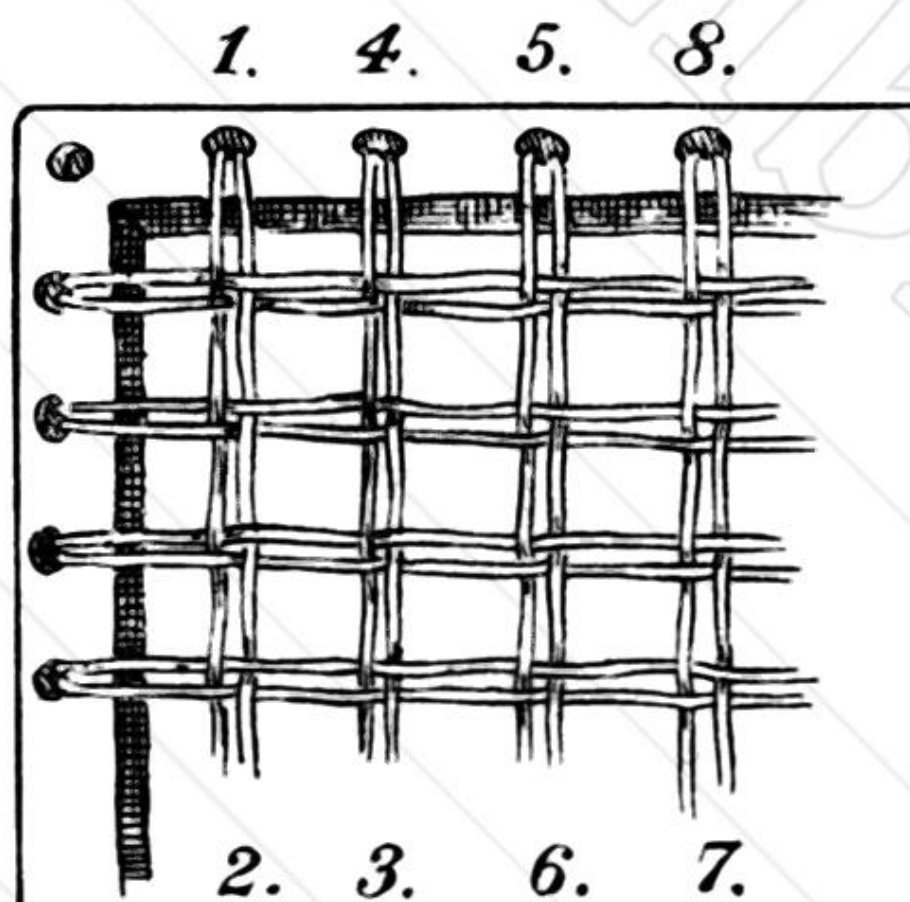

FIG. 104.

Pass both strands on the under side of slate to the next holes on both sides and repeat the weaving as before.

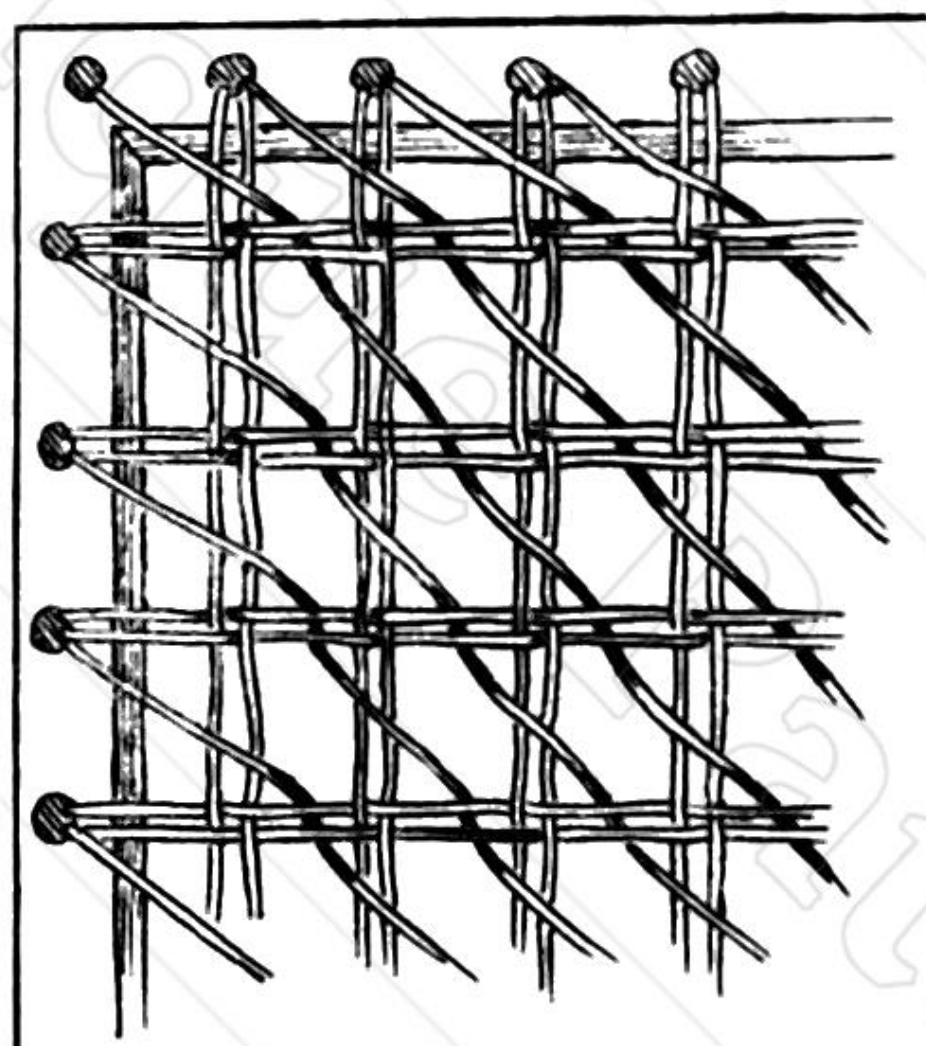

FIG. 105.

Continue till the crossing is complete.

Diagonal weaving with finer cane must now be woven across. The strands are cut in lengths, and any small pieces left from the previous weaving can be used up for the short diagonals.

The same method taught in single strand is used here. The double transverse strands are not separated, but treated as *one strand*, and the *horizontal* strands are "*lifted up*" when weaving from right to left hand corner, and the reverse—*i.e.* "*lifting up*" the vertical strands when the second diagonal begins from "*left to right.*"

This completes the weaving. The ends are threaded down into their respective holes and secured in place by a round piece of wood called a peg.

The pegs are easily made of firewood by the boys. They should be a little larger than the holes, and hammered tightly in. All ends should be cut off underneath for the work to present a tidy and neat appearance.

See that the diagonals cross each other, one under

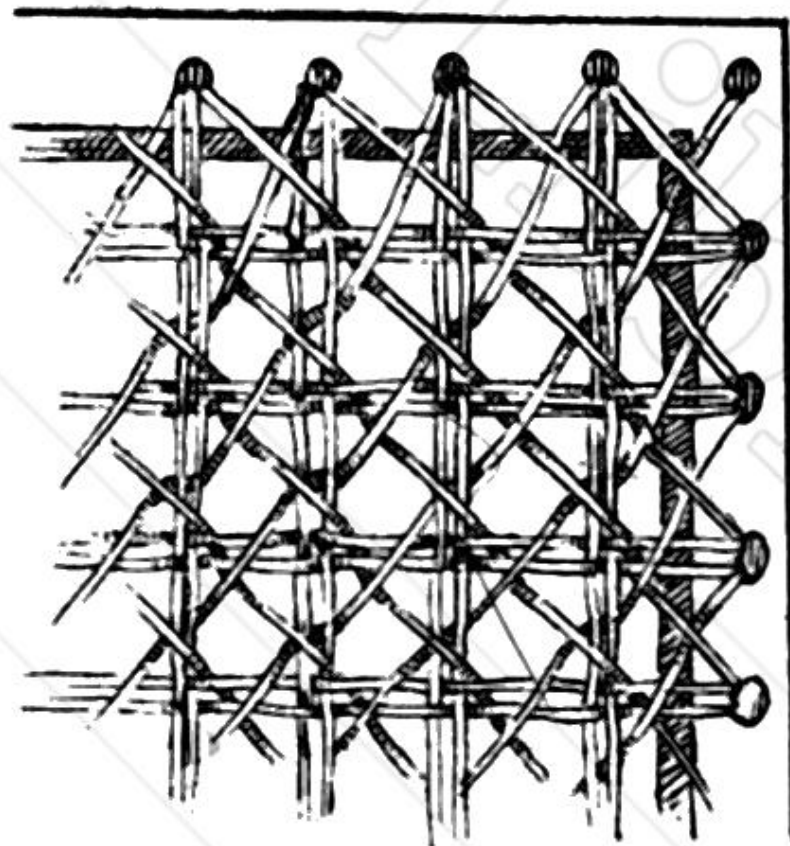

FIG. 106.

CHAIR-CANING

121

and one over, upon the double horizontal and vertical strands.

How to cane an ordinary chair will be taught in next article.

CHAIR-CANING

HOW TO CANE A CHAIR

Preparation.—1. Soak cane thoroughly.

2. Scrape off pith on wrong side.

3. Have finer cane for the diagonal weaving.

4. Cut away the old canework from chair and clear each hole with hammer and chair-caner's punch.

Materials required.—1. For single strand caning use No. 4 cane, and cross diagonally with No. 3.

2. For double strand chair-caning, seat with No. 3, and cross with No. 2.

3. Chair-caner's punch and hammer.

4. Firewood for pegs.

5. Wooden pegger.

Method of Teaching.—When the children understand the method of chair-caning as taught upon the slate frames in preceding articles, it is a great encouragement to them, and a pleasure to their parents, if they be allowed to bring a chair from home on which to show their skill.

Single strand chair-caning is the one suitable for infants, and double strand should not be attempted except on the slate frame.

The chair having been freed in all the holes from cane and dirt is now ready for caning. First count the holes *between* the corner holes back and front. In an ordinary chair there are generally seventeen holes at the back and twenty-three

holes in front. The difference between seventeen and twenty-three is six; therefore six side strands will have to be threaded three on each side, and seventeen strands from back to front. The side strands are called "scallums." To ascertain how many scallums will be required in a chair seat, always count the holes (between the corner holes) back and front, and the difference divided will be the number of scallums for each side.

Beginning.—If the number of holes back and front be *the same*, then begin with a loop on the *front* of chair; but if the number of holes be greater in the front than at the back (as in Fig. 107), then begin at the side, and work from front to back of the chair. The grain of the cane must run in this direction.

Begin, according to directions given in first lesson, at the seventh hole (side), counting from the lower corner; cross over to front and pass *down* into the first front hole—the next *after* corner hole—making a short scallum. Thread the cane up through second hole on front and cross into the tenth hole on the side, or the third hole above the last scallum. This gives the second side scallum. Pass cane underneath to the fourteenth hole on the same side, and bring it across to the third front hole. This completes the third scallum. The threading is now straightforward from back to front for seventeen rows, when the three scallums on the opposite side must be threaded to correspond with the first. The worker must judge her distances apart for the scallums on the side of the chair.

The great point to be remembered is, that they thread consecutively into the first three and last three of the front row of holes, and must run in parallel lines to the holes on side of chair. The numbers given in the above directions will slightly differ in chairs of different shapes. The back

corner holes must be kept free for the diagonal strands (Fig. 107).

Crossing.—If single strand caning is to be taught, then the transverse crossing will be commenced from the first hole *after* the corner on each side. The front of the chair being slightly curved, two or three horizontal scallums will be needed across the front. They are threaded across the

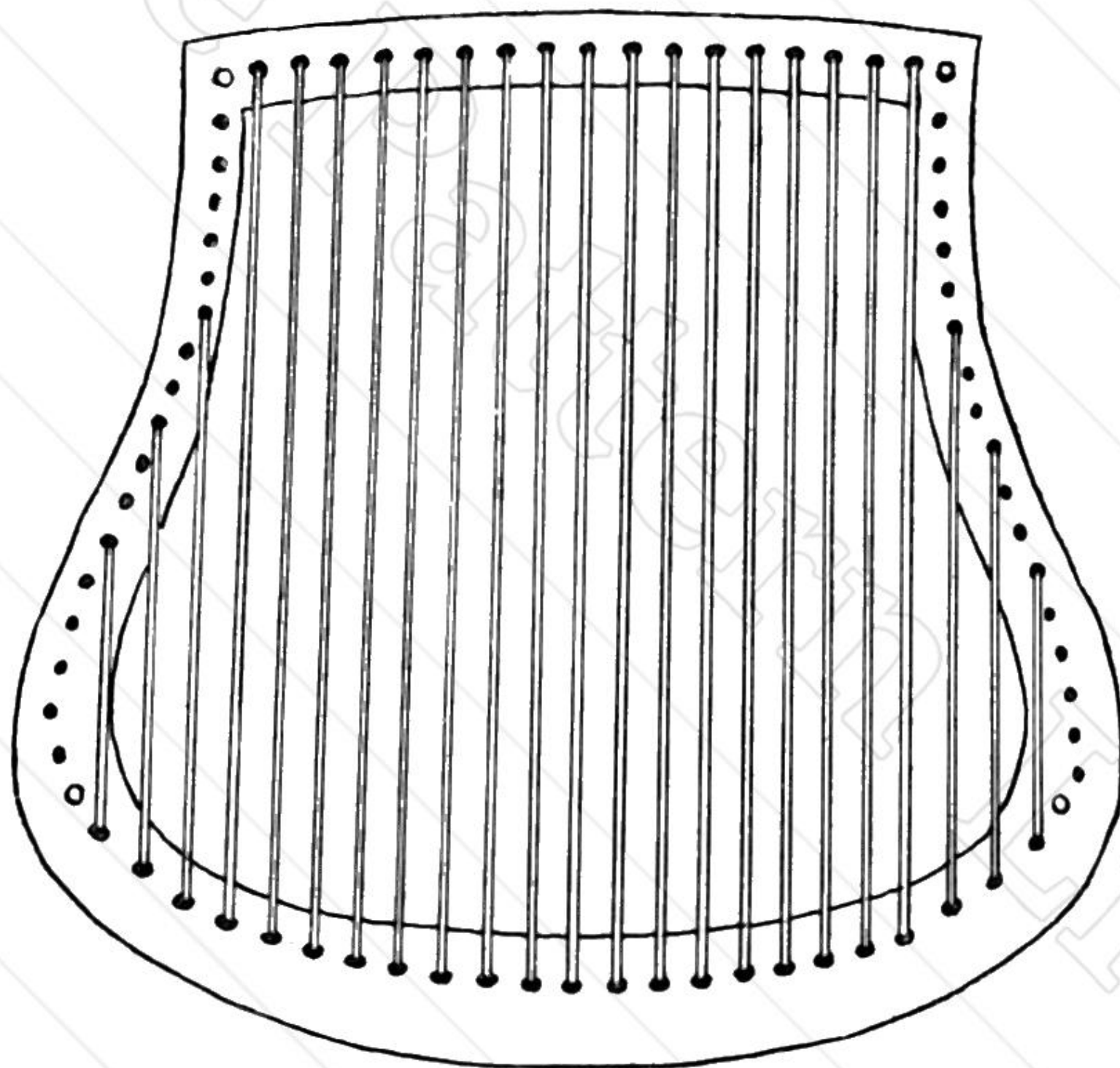

FIG. 107.

front from hole to hole, as in Fig. 108. This crossing is not to be woven, but simply laid across the top in the same manner as the vertical strands (Fig. 107).

These two crossings being complete, the diagonal strands have now to be inserted. Measure these, and cut in lengths and scrape *both* sides to give pliability. The back corner holes must not be used in either the vertical or horizontal weaving, but reserved for the diagonal weaving. Into each corner hole the ends of the two centre diagonals pass, and

the succeeding ones into consecutive holes on the sides, front and back.

Begin at bottom left-hand corner, and pass over horizontal and "lift up" all vertical strands, working from corner to corner. The ends are passed down into the holes and secured with wooden pegs.

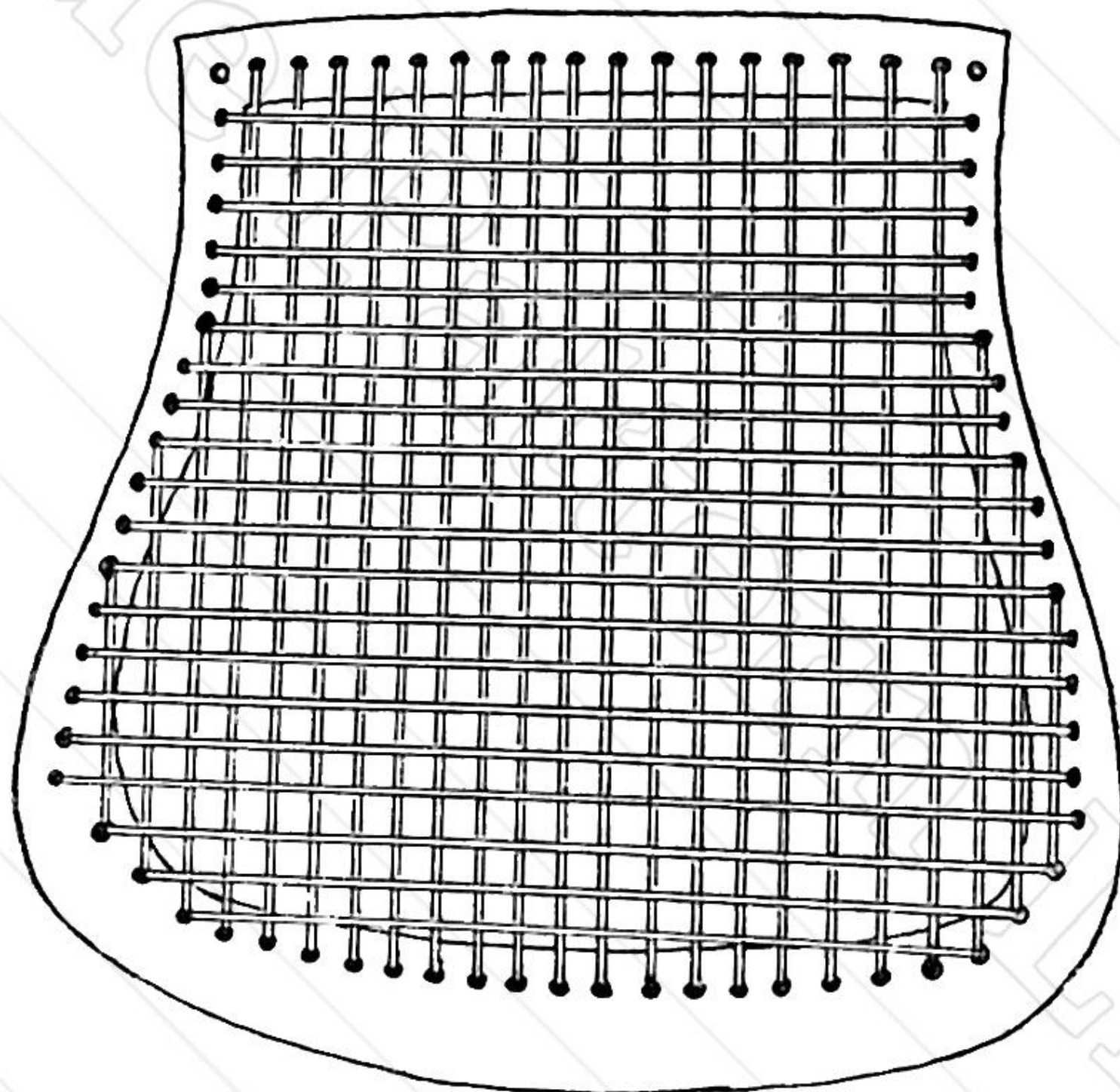

FIG. 108.

In reversing the diagonal weaving, proceed in the same way, starting from right-hand corner and "lifting up" all the horizontal strands. Remember to make the two central crossings finish in the corner holes. By so doing the diagonals will come out in a direct line to each hole on the sides. There are two or three holes up the sides that cannot be woven under; these must be missed.

N.B.—The two centre diagonals which pass into the same corner hole mean two *adjoining* strands going across the centre of the chair.

CHAIR-CANING

125

Pegging.—Split firewood into pieces the size of one's little finger, and scrape round. The pegs must be a little larger than the hole, and it is best to use the long piece as it is, and wedge and hammer into every two holes and break off until the piece is used up. This way is found to answer better than by cutting the pegs into short lengths.

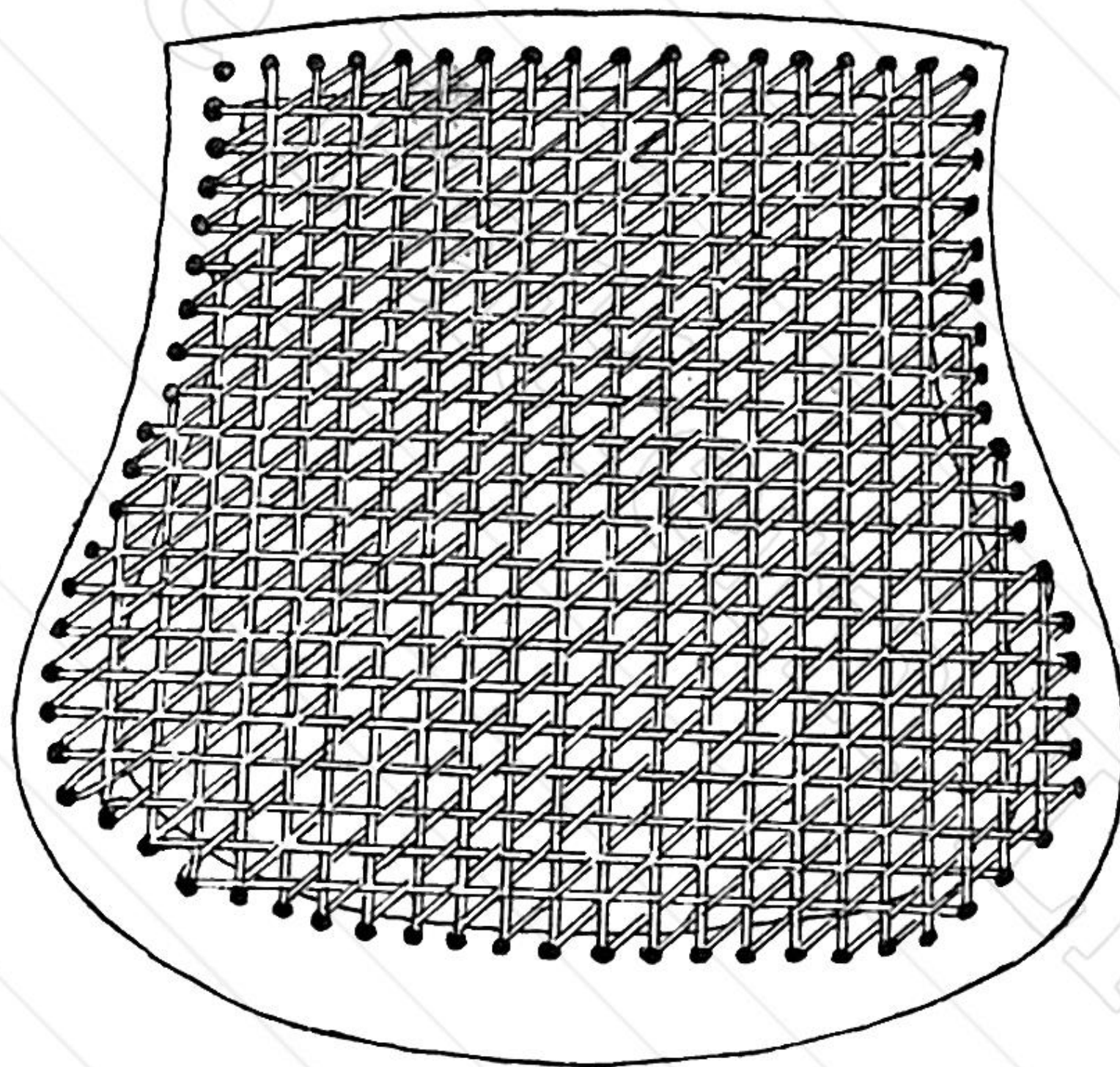

FIG. 109.

When the holes have been pegged in this way, the punch must be used and a tap of the hammer given to each peg to thrust it below the level of the chair and render the surface neat and intact. If the chair is to be finished with a beading, then every third hole must be left unpegged. The pegging not only secures the ends, but tightens the work. The cane work should be thoroughly wetted before pegging.

Beading.—A coarse cane, No. 5, is suitable for beading. Measure off approximately the length required to go straight

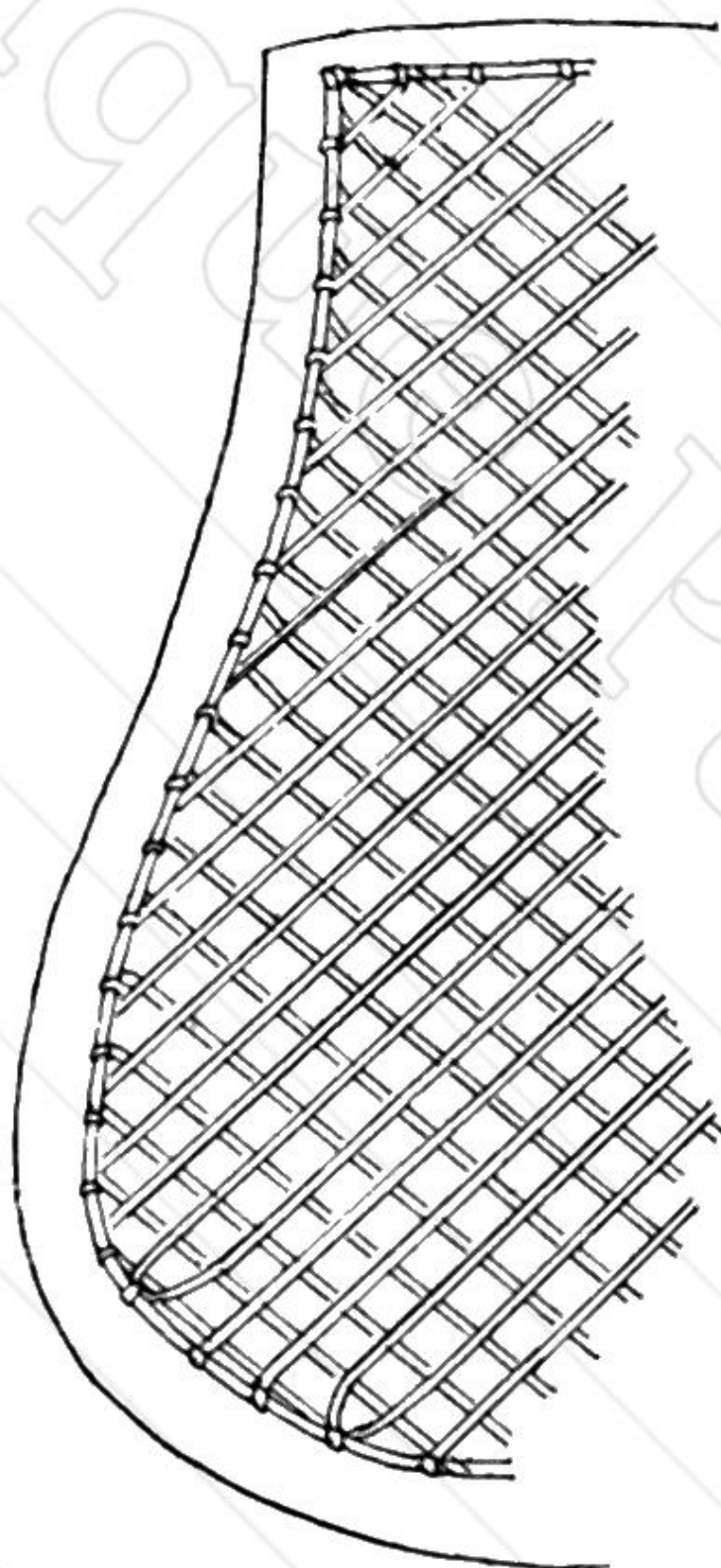

FIG. 110.

round the chair. Soak and scrape the cane. Begin at the top corner hole at the back, pass the end of the beading cane into the corner hole and temporarily secure it with a wooden pegger. Take a long length of fine cane for the threading, and pass it up through the first hole on the side which was left unpegged. Fasten the end on under side with a knot. Bring the beading cane smoothly and flatly down from corner hole to the threader, pull tightly, and pass the threader over the beading down through the same hole again. Pass the threader underneath to next unpegged hole, and continue to loop over the beading cane all

round the chair through every unpegged hole. The beading cane must be all in one piece and nicely rounded at the front corners. It is finished off in the same hole where it began, and is secured by a peg. The under side of the chair should present a neat appearance, all ends and knots after pegging being cut away.

SPLIT STRAW WEAVING

Description of Occupation.—This occupation is an admirable one to supplement mat-plaiting, and is desirable

to have going side by side with it, as a reward for the most diligent and careful. It cannot be recommended for a *large* class of infants, as it requires a certain amount of care and skill, and does not admit of *teaching* upon; but as an occupation for older children of Standards I. and II. it cannot be too highly recommended, because these children will be *au fait* with numerous patterns in weaving and need no teaching on that point, and their attention can be wholly directed to the new difficulty of handling straw. The occupation is very fascinating and one much liked by children.

Educational Value of Occupation.—It trains the “hand” to be skilful and dexterous, and the “eye” to be exact and accurate. It cultivates a taste for designing patterns and the harmonious blending of colours. It is a development of Kindergarten knowledge already acquired, and is a clean and inexpensive occupation. The work can be made any size and cut to any shape, and is durable and suitable for making useful articles.

Material used.—The straw used is the ordinary corn stalk or reed. The stalks are sold in bundles of 100 at 4½d. per bundle, much used for straw plaiting, an industry which is largely carried on in Bedfordshire and the adjoining counties.

Very superior straw is produced in Italy from the fine corn cultivated there for macaroni. If this kind can be obtained very delicate and artistic work can be produced, as the straw is of a finer grain and whiter colour.

Manufacturers sell the straws ready dyed in the following colours:—Crimson, gold, light blue, dark blue, purple, green, brown, and plain cream. Any of these colours will harmonise well with the undyed straw.

Splitting the Straw.—The straws may also be obtained in

bundles ready split, but if bought whole the splitting can easily be done by the children, and form a preliminary lesson to the weaving. The splitting entails a certain amount of waste, because the straws are brittle and will easily break if not carefully handled. To split straws successfully the bundle should be placed on end over steam, until the straws become somewhat softened, when they are easily split and flattened without much loss. A great objection to steaming and wetting the straw is that it is likely to change colour and turn from a pale cream to a butter yellow. With care the splitting can be managed without.

Method for Splitting.—Implement for children—a knitting needle. Implement for teacher—a penknife.

Give each child six straws and a knitting needle, and interest the children in their new work by talking about the straw—where it comes from, how it is used, etc.,—and show the class some finished work in straw weaving to give them an idea of what is expected of them, and create a desire to do likewise.

First demonstrate the splitting and flattening before the children, and make all intently watch and describe what is being done, then with the following simple drill let the children repeat the process.

Commands.—1. Take straw in left hand and hold upright.

2. Take knitting needle in right hand.

3. Insert the point of needle into the tube of straw at the top and draw it quickly down the side.

4. Hold the straw on desk with left hand and flatten both sides with the knitting needle, until all curl has disappeared.

During this lesson the teacher should pass round the

SPLIT STRAW WEAVING

129

class, collecting all good flattened straws, which she should *at once* place in a box and keep ready for future use. English straws split in this way are about three-quarters of an inch wide, but the straws may be split in half for small patterns. A straw splitter is the correct thing to use and may be bought for a few pence, but if the teacher has time she can quickly cut the straws down in half with her penknife and give to the children to flatten.

Preparation by the Teacher.—To make this occupation suitable for class work, the writer uses the following simple clip for holding the straws, which the teacher must prepare herself, until Kindergarten publishers come to the rescue with something better :¹—

Buy one yard fine muslin or Victoria lawn and *paste* it evenly upon a large sheet of cartridge or brown paper, so as to render the latter untearable. When dry, cut the fortified sheet into strips 2 inches wide. Subdivide these into *lengths* of 8, 10, or 12 inches, according to the size of the weaving required. Remember the clip must be cut 2 inches longer than the *width* of the piece of work required.

Take each slip and pencil off 1 inch from either end. The intermediate part divide equally into three parts, and with a sharp penknife and ruler cut two slits from pencil line to pencil line (see Fig. 111). The clip should be consistently stiff and yet pliable and untearable, and one or two must be provided for each child. Start with making small pieces, and cut up a stiff blue Kindergarten No. III. mat for the clips. This work should be kept upon sheets of cardboard or millboard, and the same collected, entire, each time and placed one upon the other until finished.

¹ Messrs. Spicer and Co. of 19 New Bridge Street supply the above clips in three sizes for this work.

Method of Weaving.—*Materials for each Child.*--1. Two paper clips (as described).

2. A long plaiting needle or wooden lath or knitting pin.

3. A millboard or sheet of cardboard.

4. A dozen split straws ready flattened.

Each child takes his clips and places them together vertically before him, and then interlaces the straws in the four centre strips as if plaiting an ordinary mat. Let children push the straws well through the two clips and keep close together until all the space is filled, simply weaving "one up and one down," and then reversing the process.

This done, turn the *filled* clips horizontally and secure the two ends of top clip to the millboard with two drawing pins, or if ordinary cardboard, pin or sew with a few stitches. By using the cardboard or millboard each child's work can be labelled and protected from breakage, which would occur if collected unattached.

The second clip must be gently drawn down and the straws also pulled down to the top edge of the clip ready for the weaving. This stage represents the Kindergarten mat, and if desired the lower ends of the straws may be fixed to the board, as in Fig. 111, but it is found much easier to manage if the lower clip is left loose. Any pattern can now be woven.

The Needle.—There is no needle suitable for the wide straws, but one might easily be made of wood, steel, or cardboard, with a pointed end for "*picking up*" the straws, and a slit or spring at the other end in which to insert the strip. The children use the long wooden plaiting laths or knitting pins to raise the straws, and when the whole are "up" correctly the straw is slipped in at the side and the lath or pin withdrawn, whilst the straw is

SPLIT STRAW WEAVING

131

pushed up into place. The ordinary steel plaiting needle is useful for the narrow straws, and a wide one made upon a similar principle is now manufactured by Mr. T. Canner of Leicester for this work.

Joining or enlarging the Work.—It sometimes happens that

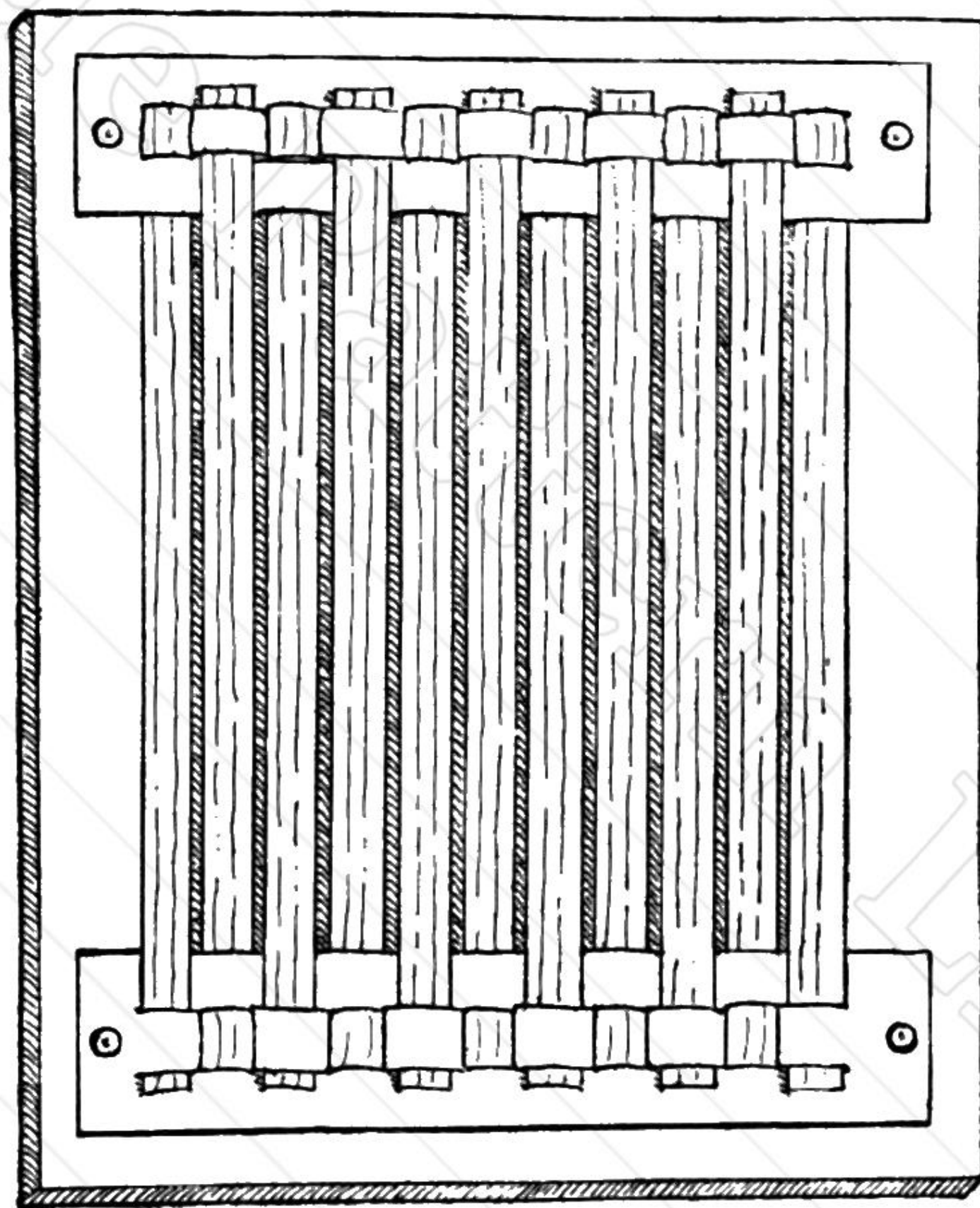

FIG. 111.

a straw will get snapped off or used up ; if so, a new one is easily added. Take a new straw of same size as broken one, and with penknife or needle just lift the loop of the last cross straw above and push up the new straw until the end below corresponds in length to the others. Let the upper end remain outside and go on weaving, and after a few rows gradually draw the new straw down until the end is

concealed by the cross loop under which it was pushed. No joins should show, nor the work be impaired in the slightest, by the addition of new straws. The work can be enlarged in the same way on either side if needed. Turn the work and insert new straws into the last cross loop of the weaving, as before described.

Cut off all ends underneath, after the new straws are secure. Keep the straws well pushed together, not overlapping, and yet no spaces left in the corners of the pattern. When the board is full the straws should be pulled gently down from the clip, as the weaving will now keep the whole intact.

How to Utilise.—Decide upon the object to be made and cut the shape out in cardboard. From time to time lay pattern upon the work to see if large enough, and if it is then remove the straw weaving from the millboard, cut off all untidy ends at back, and lay with glazed side downwards.

Use prepared paste or gloy, and paste over the cardboard shape. Place it in position on the wrong side of weaving and cover with a millboard (to keep flat), and a heavy weight on top. This process gives a beautiful flatness to the work and enhances its beauty. When dry cut the straw work to the cardboard shape. Finish the edges either by binding them with ribbon or braid, or better still, by edging them with a row of straw-plait vandyke edging.

Manufacturers and Price List.—Coloured straws, red, blue, green, gold, brown, and white, are sold at Church Extension Depôt, 5 and 6 Paternoster Row, at 4½d. per 100, and vandyke edging, 8d. per bundle of 20 yards. Superior coloured straws in art shades are sold at Wakeford Bros., King's Road, Chelsea; and at Higgins and Co., George

Street, Luton, at 9d. and 10d. per bundle; and mixed vandyke edgings to match at 1s. per bundle of about twenty yards. Plain white vandyke 10d. per bundle.

SLIPPER POCKET

Materials. — 1. Ordinary stiff paper, Mat No. III., cut up into clips.

2. Split brown and cream straws, $\frac{1}{4}$ inch.

3. Steel Kindergarten plaiting needle.

Method. — These small articles are best for beginners, because they have their Kindergarten needle and mat as helps. Insert the cream strips and weave with brown. No joins will be necessary, as the length of the straw will cut the sole of slipper, and another portion must be woven for the toe. Two slippers alike must be made and tied together in pairs. They are useful for hanging on the toilet glass, to hold hair-combings. Cut two shapes according to measurements in Fig. 113. The toe cap to be $4\frac{1}{2}$ inches at its widest part and $3\frac{1}{4}$ inches long. Paste and flatten as before directed and finish off with small vandyke edgings.

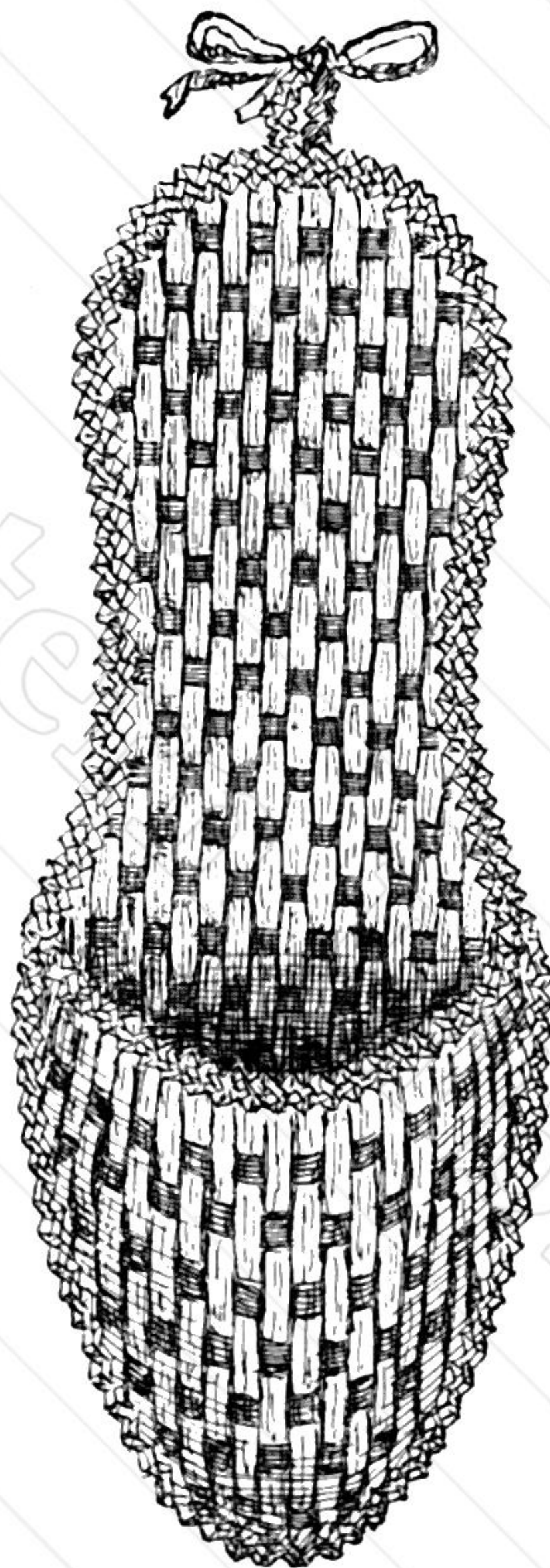

FIG. 112.—Slipper Pocket.

Some of the edgings now made are in mixtures of cream and red, green and cream, and red and green; and if the

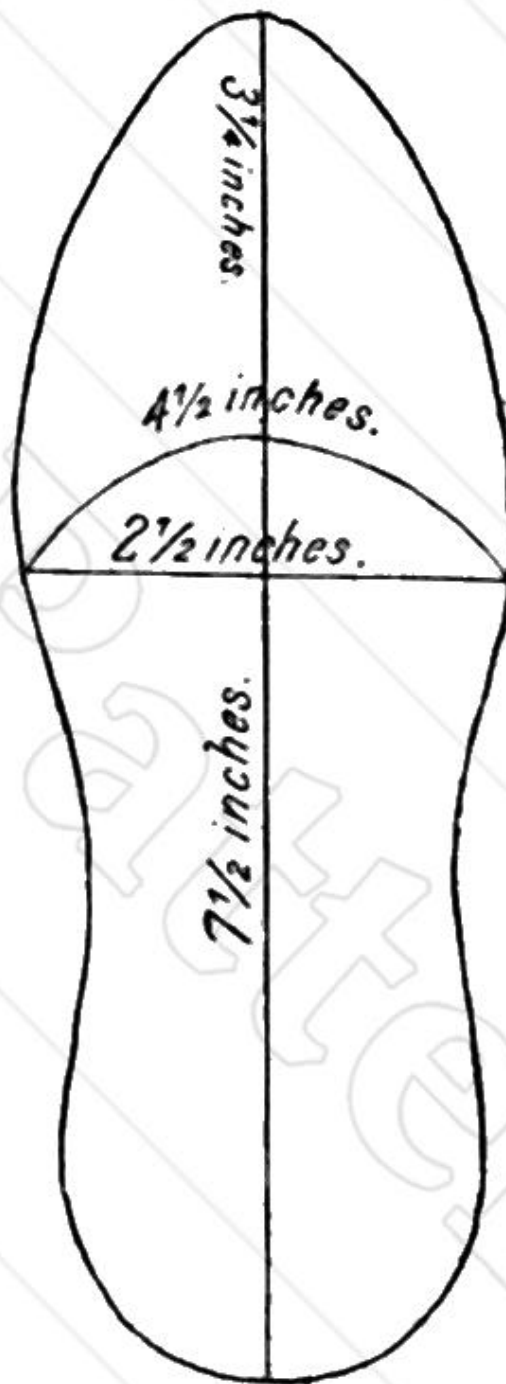

FIG. 113

weaving corresponds in colour, most delicate and artistic work is produced.

DINNER MATS

There are six dinner mats to a set—two large, 12 × 9 inches; two medium, 10 × 8 inches; and two small, 9 × 7 inches. It is best to decide beforehand what is to be made, and cut the cardboard shape out first, so that a child knows exactly what is required of him and will take greater interest in his work. Let the whole class be at the same employment at the same lesson because change is desirable, and for one child to make a whole set of dinner mats would be monotonous. It requires twelve pieces of weaving for a

SPLIT STRAW WEAVING

135

set, and this might be obtained in one lesson if the work is given out properly prepared.

Cream or plain undyed straws are best for dinner mats, because they do not fade with the heat of the dishes, and are easily sponged and kept fresh.

Materials required.—1. Six stout cardboard shapes—two, 12 × 9 inches; two, 10 × 8 inches; two, 9 × 7 inches, of an oval shape.

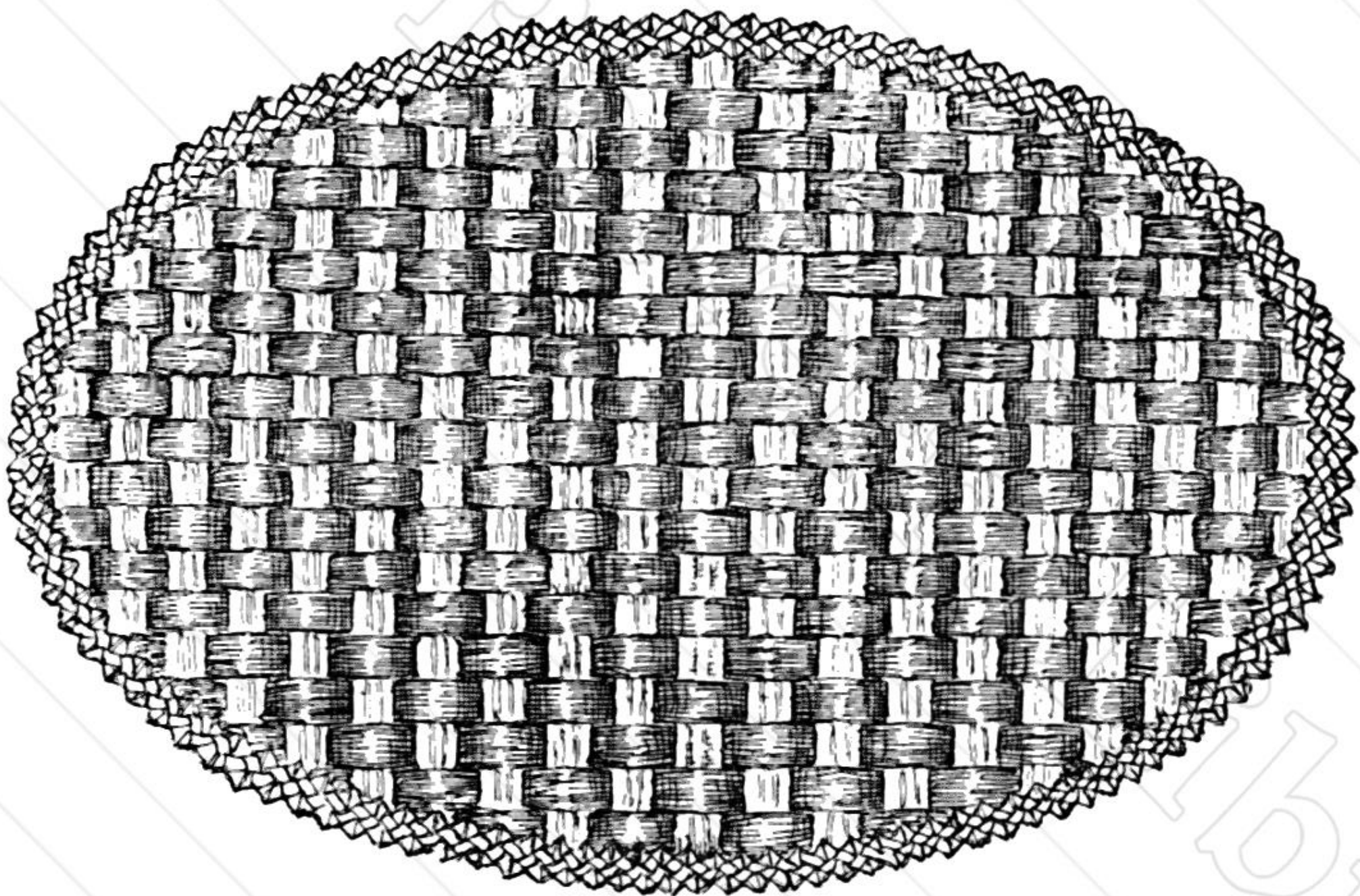

FIG. 114.—Dinner Mat.

2. Plain white straws split open, $\frac{3}{4}$ inch wide.
3. Straw clip made in three sizes (as described).
4. Thin lath or needle for lifting up straws.

Method.—Cut the clips 2 inches longer than *width* of mat, which will be 11, 10, and 9 inches. Let each child interlace its own straws in the clip, and when full, the teacher should fasten same securely to a millboard or piece of stout cardboard. For first lesson, give the simple

pattern, one up and one down, until the children have overcome the difficulty of treating with the brittle straw.

The oval cardboard shapes must be cut with mathematical precision. This is best obtained by using a loop of string and two drawing pins, and inscribing the ellipse with the loop of string and a pencil.

How to draw the Ellipse.—Make a double loop of string the length of mat. Knot together. Draw a pencil line upon cardboard the exact length of mat, and fix a drawing pin

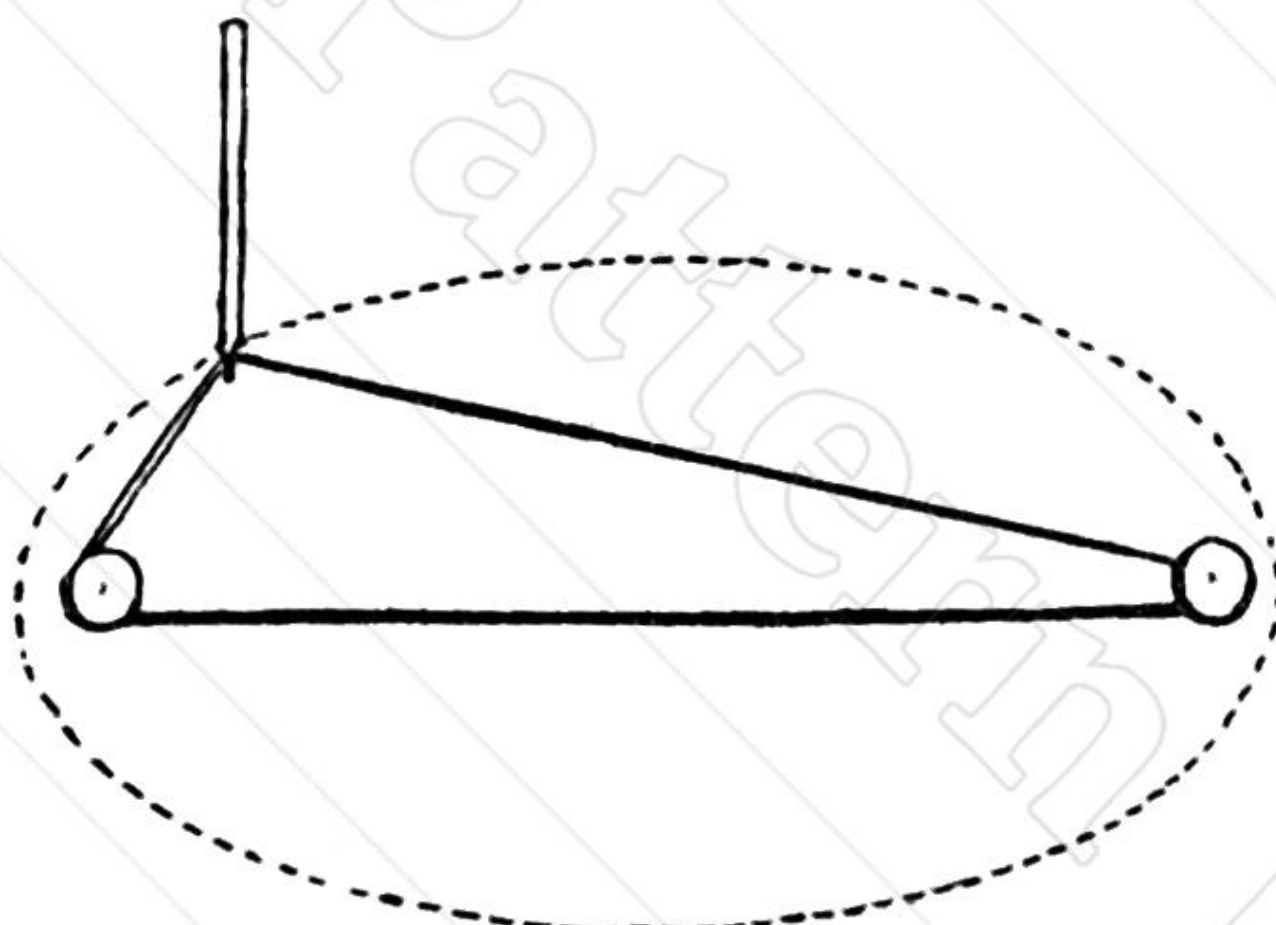

FIG. 115.

about half an inch from either end of this line. Place the loop of string over the two pins. Hold pencil nearly upright with point inside the loop and thus describe the ellipse, keeping the string *tightly* strained from drawing pins (see Fig. 115).

When each piece of weaving is the size required, let the straws be gently urged towards the centre from top and bottom and sides. If the work be not wide enough, it can be turned round and new straws inserted just the same as at the bottom, and be widened or lengthened to any extent.

Collect all the work when finished and keep between the leaves of an old summary or register till mounting day.

SPLIT STRAW WEAVING

137

From experience it is found best to have a quantity mounted and finished off together. Some of the most careful children may be chosen from time to time for this part of the work, and they will do the pasting of the cardboard efficiently ; but the teacher should lay the straw work in position, and then let the child smooth and press with a piece of blotting-paper until the work has partially adhered. It should then be replaced with its cardboard shape in the large book, or between millboards, and left all night with a heavy weight upon the top. This will ensure a beautiful flatness, which cannot be got by any other means, and has always brought forth remark at the work produced in the writer's school.

Finishing.—If older children than six years take this work, the whole may be finished by the children, but if infants of six years take it, the finishing had better be done by the teacher, especially where *stout* cardboard forms the foundation, because the needles broken are a source of trouble, and the little hands are not strong enough to push through such a firm thickness. Dinner mats may be bound with braid or strips of American cloth, but to give the *best* finish to the mat, nothing excels the straw vandyke edging sold for the purpose. This is sewn on both sides, so that either side of the mat can be used.

The two sides might be woven in different colours if desired, or different patterns to give variety to the work.

Crimson and cream are colours which go well together, and two up and two down, starting *one* strip to the left each time, gives a very pretty step pattern and yet easy to do.

Tie all the six mats together with coloured ribbon to match the straws, and sell as a set.

BLOTTER

Materials required.—1. Blue and cream straws split open, $\frac{3}{4}$ inch wide.

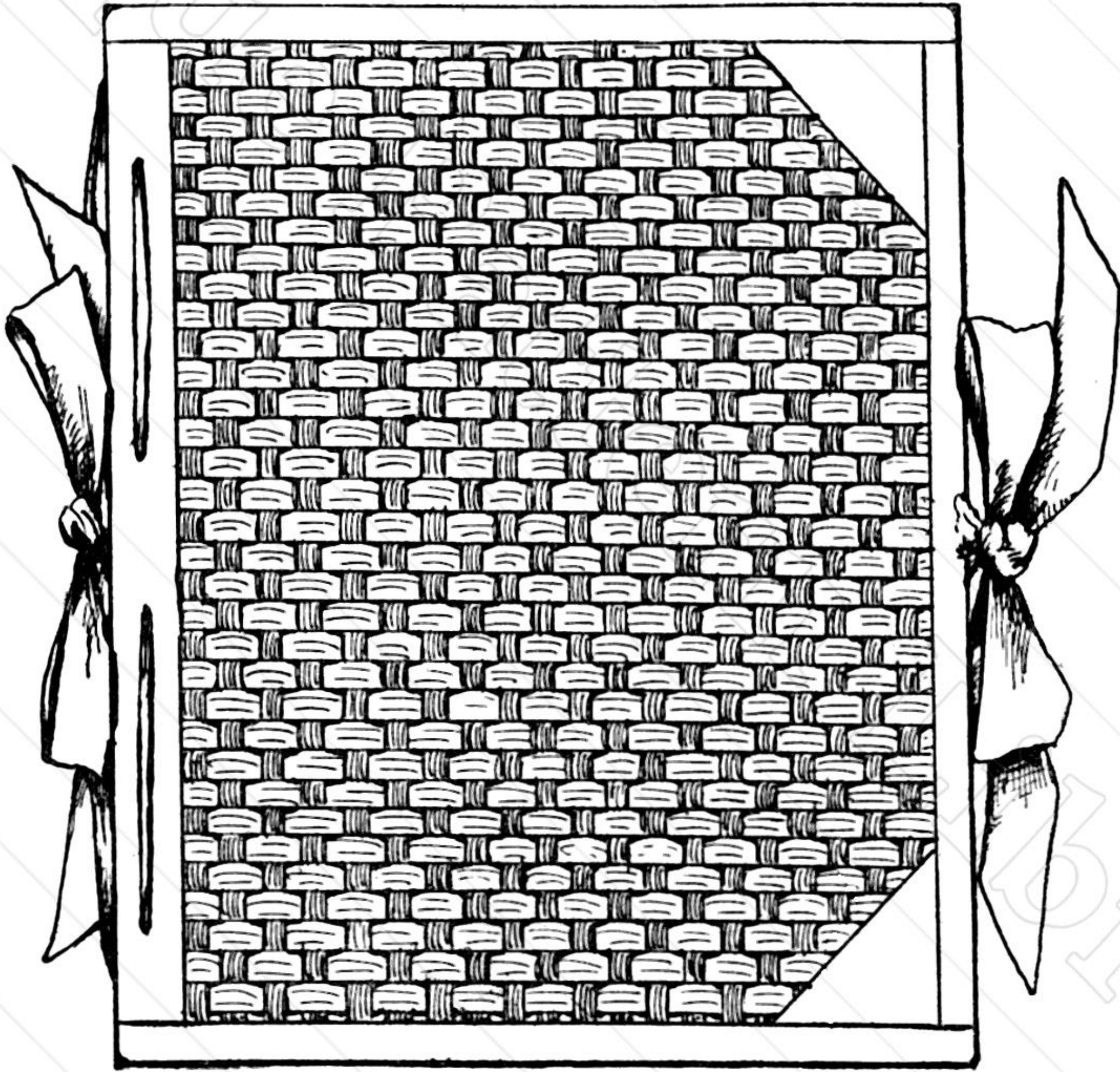

FIG. 116.—Blotter.

2. Paper clips, 12 inches long.
3. Navy blue morocco paper.
4. Two stout pieces of cardboard, 12 × 10 inches.

Method.—Two pieces of weaving, blue and cream, measuring 12 by 11 inches each, are required for the

SPLIT STRAW WEAVING

139

outside covers. Eighteen cream straws are interwoven into the clip, to form the mat, and twelve blue straws of same width are plaited "one up and one down" across the cream straws, reversing every alternate row. See that the straws are well pushed up and form exact squares of blue and cream.

The cardboard mounts must now be cut. Stout cardboard is the best to use. Rule a line down the cardboard edges and be careful that the lines are *straight*, then cut accurately with ruler and sharp knife.

When all ends underneath, caused through joining, have been cut off, and the weaving neatly pasted to the cardboard mounts, then lay one upon the other, with paper between, and place under a heavy weight, or better still, in a press.

Binding.—To join the two covers together, and form a hinge at the back of book, take some unbleached calico and cut a strip precisely the length of the covers and 2 inches wide, so that it will wrap over well on each cover. Lay the two covers side by side, almost touching, and paste the strip down the back edges, on the weaving side. It is best to do this and leave to dry, as it holds the blotter strongly together when finishing it.

The Inside.—Line the inside with the morocco paper and bind the edges. To do this turn covers, with cardboard side uppermost, and cut enough paper to cover *both* sides of the blotter, and to allow for the bind. This inner lining should be about one inch larger than the book on every side, except the back, where it goes straight across the hinge back. Paste it on very evenly and smooth out any lumps of paste by using the hand in preference to a brush. Be sure that the outer edges of the paper are straight, and when the inside is pasted, turn covers and fold over the edges upon the right

side where they should lie evenly, and make a good binding for the edges.

Corners.—Take care to turn the corners sharply by snipping out a portion so that they are not bulky.

If the corners are not good paste across four corner pieces of paper. Before finishing the back it is perhaps best to fasten in the blotting-paper. Make four holes right through the sheets of paper and the calico back, two in the middle and the other two about one and a half inches on either side. Stitch the blotting-paper through these holes two or three times with strong thread, or another way is to fasten a piece of elastic over the back and inside of book and slip the leaves underneath. This latter method is good for easily changing the paper when required, but the first plan is the better for making scrap-books, etc. When this process is complete, the book is ready to bind ; take a strip of morocco paper of the same width as the first strip of calico, and paste it upon the other at the edges only, so that the elastic can be slipped in or out, and the stitches hidden.

Decoration.—The book may be decorated with bows of ribbon back and front, or edged with straw vandyke edging over the binding, which will greatly improve it, but be more expensive.

PHOTO FRAME

Materials required.—1. Cream and gold straws, split in half, $\frac{1}{4}$ inch width.

2. Paper clip, 11 inches.

3. Stout piece of cardboard, 10 × 8 inches.

4. Ordinary steel plaiting needle.

Method.—The cream straws form the foundation, and

SPLIT STRAW WEAVING

141

thirty-two half straws are interlaced into the clip. The gold straws are of same width and are woven in horizontally one up and one down, but they are not pushed tightly up to form squares. The reverse process is adopted, i.e. the

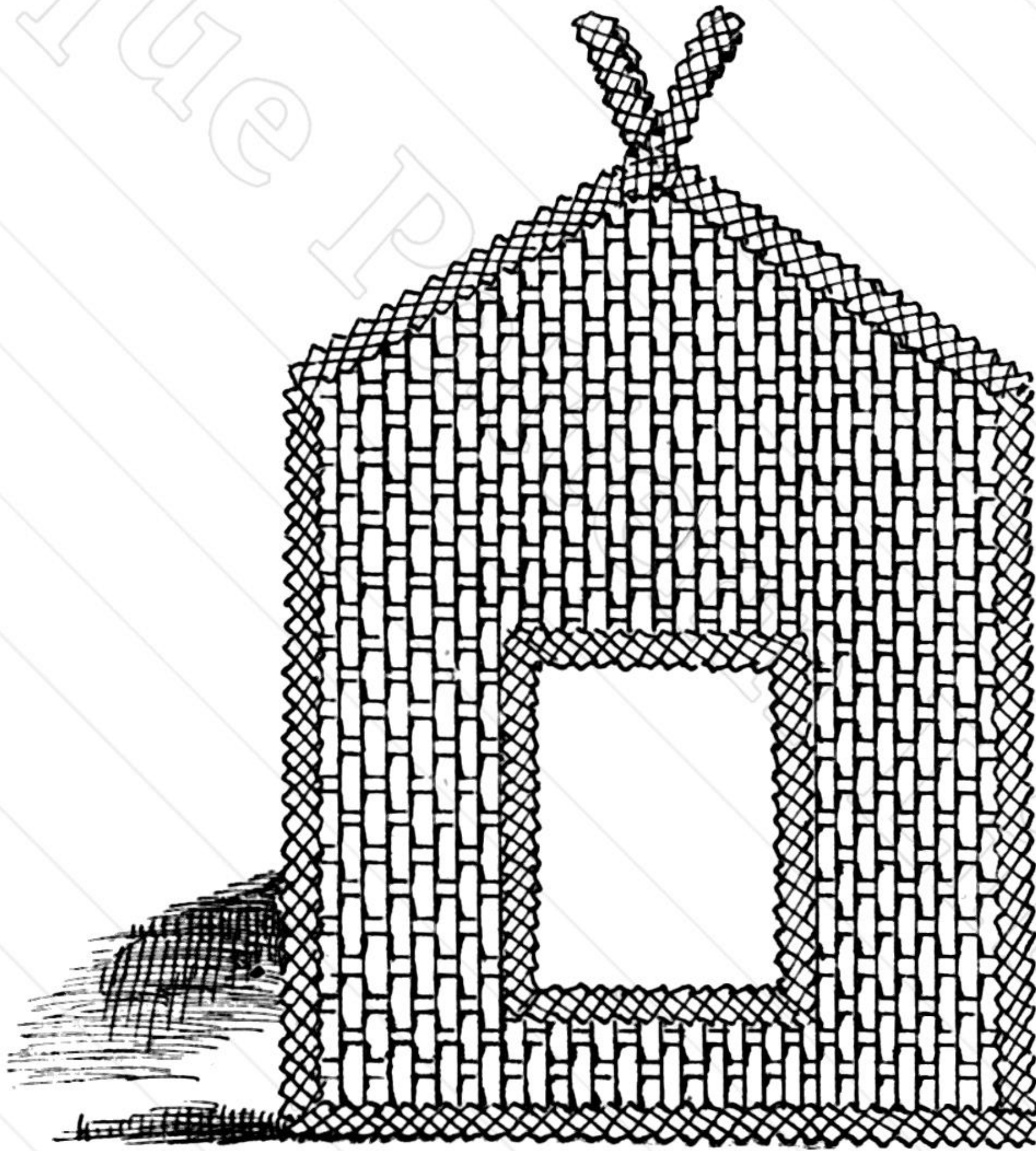

FIG. 117.— Photo Frame.

cream straws are kept rigidly together, and therefore keep the gold farther away, giving the appearance of cream oblongs and gold squares.

The size of piece required is 10 inches long by 8 inches wide.

Cut out with sharp penknife the cardboard shape, according to measurements given in Fig. 118, and cut out the centre (3×4 inches) at the same time.

Paste the cardboard shape on weaving and leave under weight till quite dry.

Next cut edges close, and carefully cut away the straw

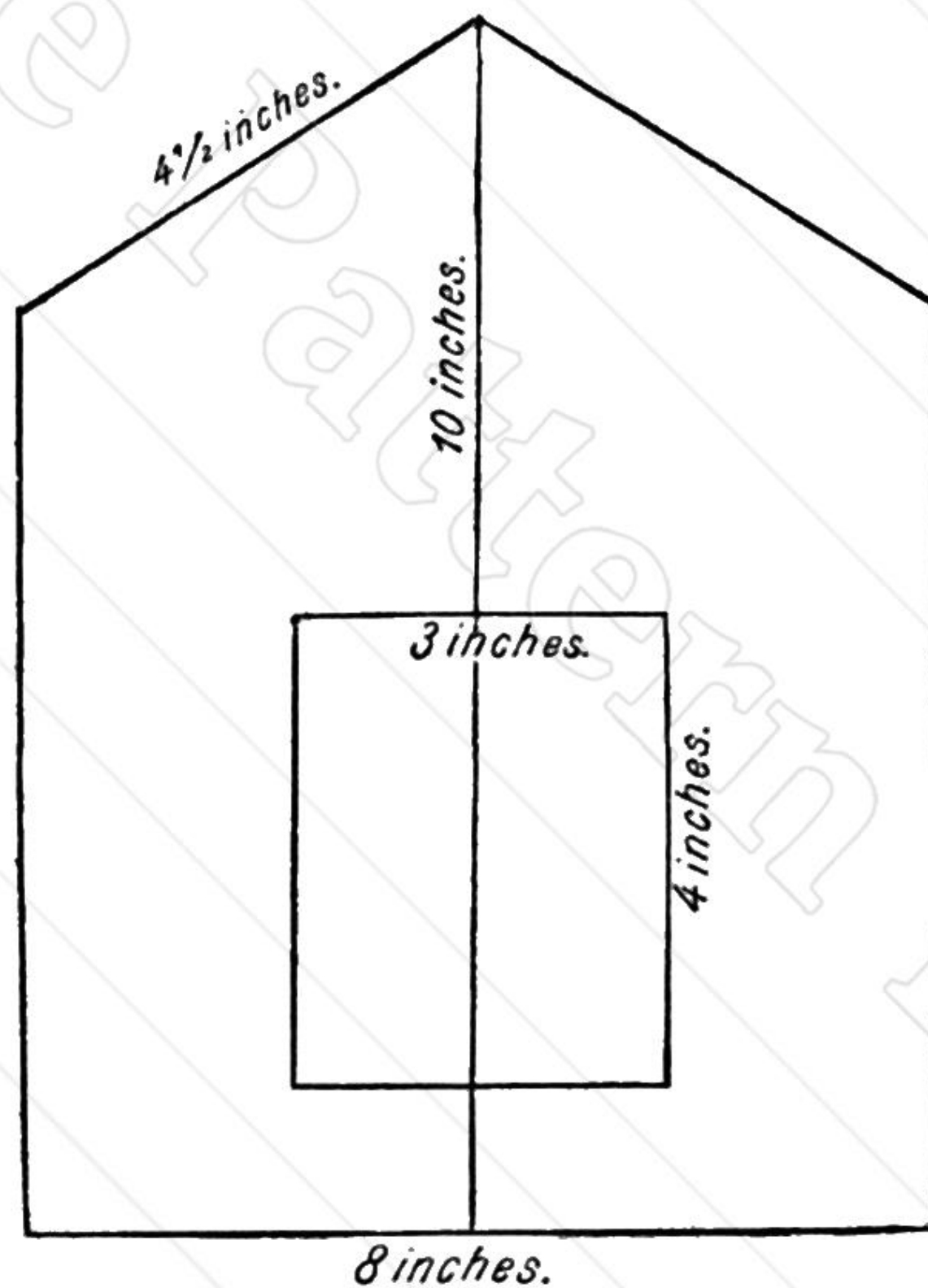

FIG. 118.

work which covers the open centre. Snip this first in the very centre and gradually cut to the cardboard edge. Immediately finish the edges by sewing on a narrow vandyke edging, first round the centre, then the outside border.

Next cut another piece of cardboard of same size but with centre intact. Cover one side of it with morocco paper, and the other side paste to the back of frame.

SPLIT STRAW WEAVING

143

Leave the bottom unpasted so that a photo and glass can be slipped up between. Screw in a small ring at the top to suspend the frame, or add a triangular piece of cardboard in the centre of back, with a strip of morocco leather paper,

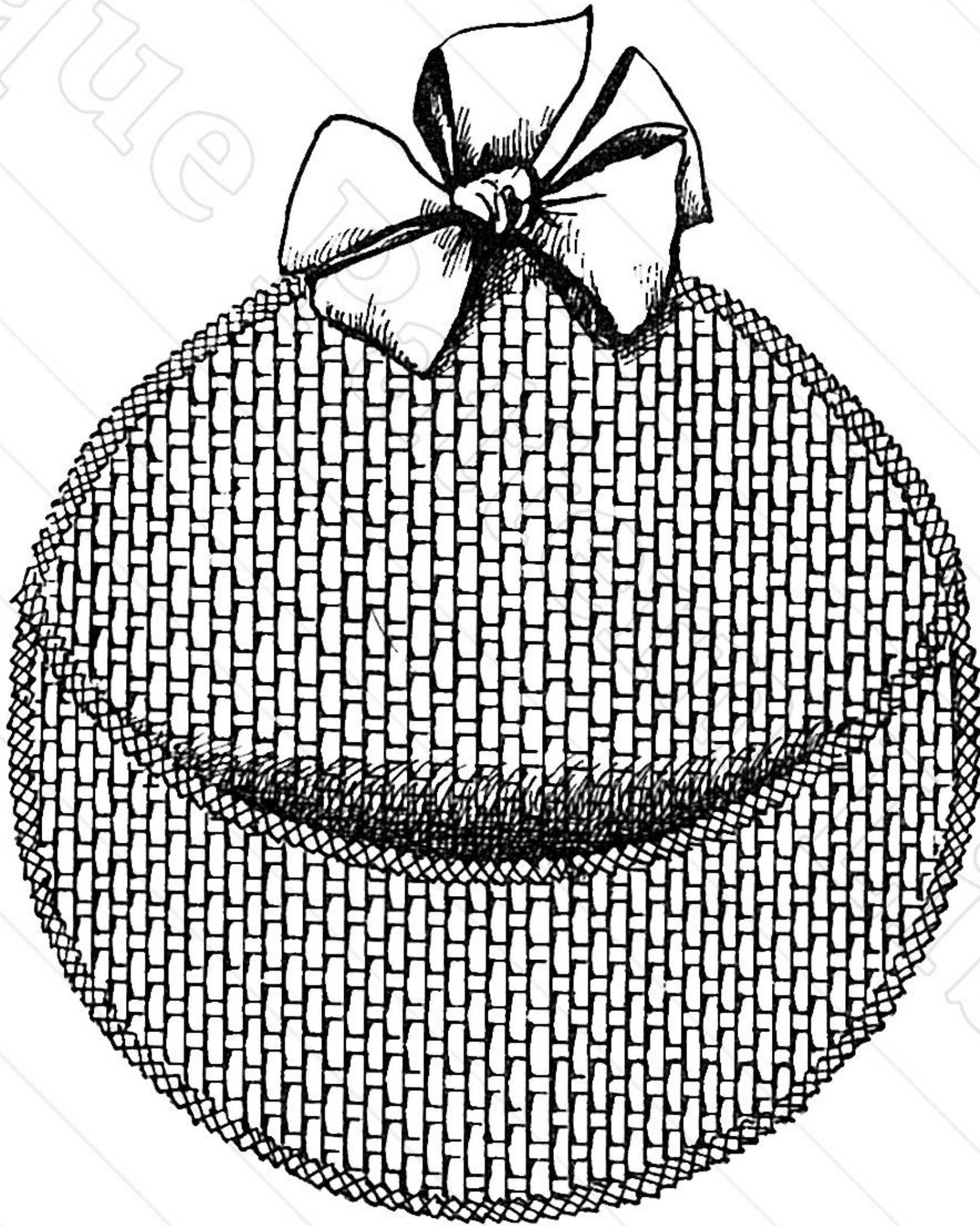

FIG. 119.—Circular Pocket.

which will act as a hinge and allow the frame to stand on a table.

CIRCULAR POCKET

Materials required.—1. Straws gold and brown, half width.

2. Two circles cardboard, 7-inch and 8-inch diameter.
3. Straw clip, 10 inches, 8-inch slits.
4. Vandyke edging, narrow.

Method.—This is a very easy article to make and can well be copied from the diagram and measurements given.

Two pieces of weaving, 8 inches square, are needed.

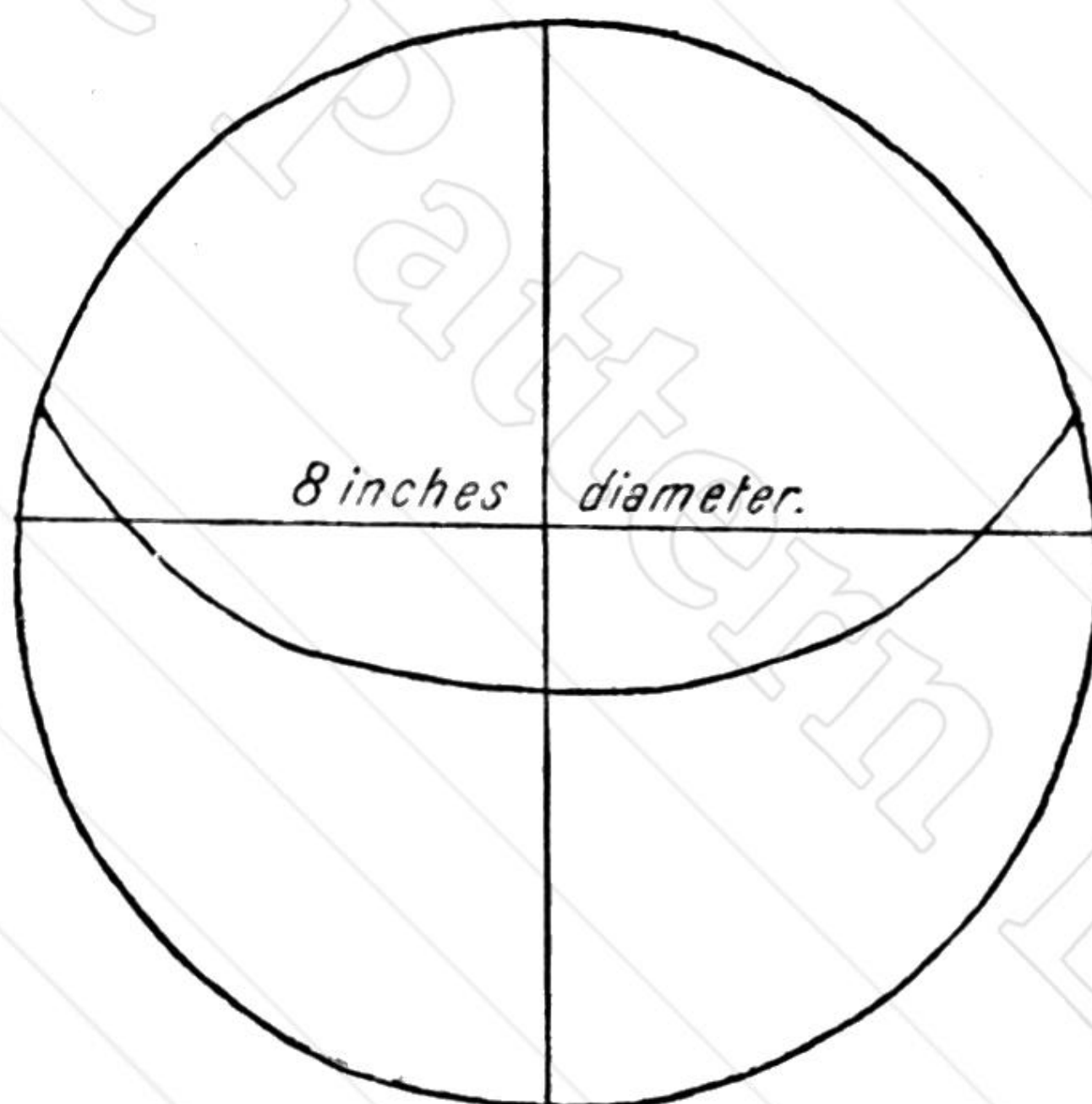

FIG. 120.

Cut and paste one circle of 7-inch diameter for back of pocket, and the other circle must be one inch larger to allow it to bend outwards. Cut this second circle in half-moon shape and fix to lower part of the first circle. Finish the two together with vandyke edging and make the back neat by covering with a circle of leather paper. Add bows of ribbon if desired. Save all cuttings of straw of 2 inches or more in length, as they will be useful for flowers in a later lesson.

BOAT COTTON BASKET

Materials required.—1. Straws green and gold, split in half.

2. Clips of 7 inches, and slits 5 inches (Mat III.)

3. Ordinary mat-weaving needle.

4. Sheet of Bristol cardboard.

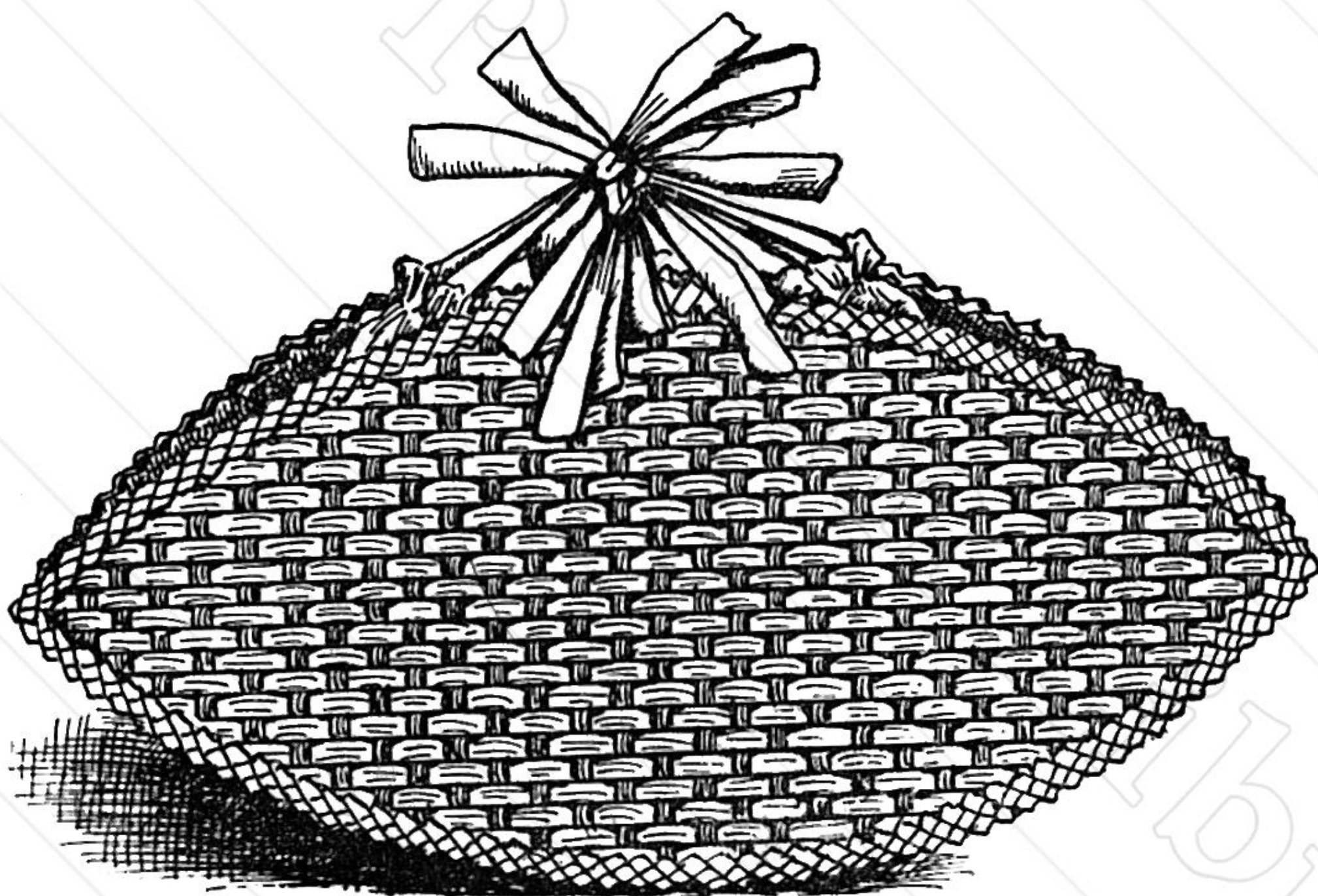

FIG. 121.—Boat Cotton Basket.

5. Medium width vandyke edging.

6. Old gold sateen for lining, $\frac{1}{4}$ yard, and ribbon.

Method.—This useful article is very simple to make, as the pieces needed are not of any great size, and therefore are quickly done. First cut the three sides in Bristol cardboard, according to the measurements given in diagram. Set three children to weave the three pieces alike needed for one basket. Interlace twenty-four green straws of half

L

size into each of the three clips, and weave with the gold straws. Three pieces of weaving 10×5 inches are needed for the basket. Paste each piece to cardboard shapes and finish with vandyke edging, separately, before joining together. When each piece is complete, slip-stitch the edges together to the shape of illustration.

Make a bag 10 inches wide for the inside, and catch the corners to the corners of basket, and then to the top. Draw

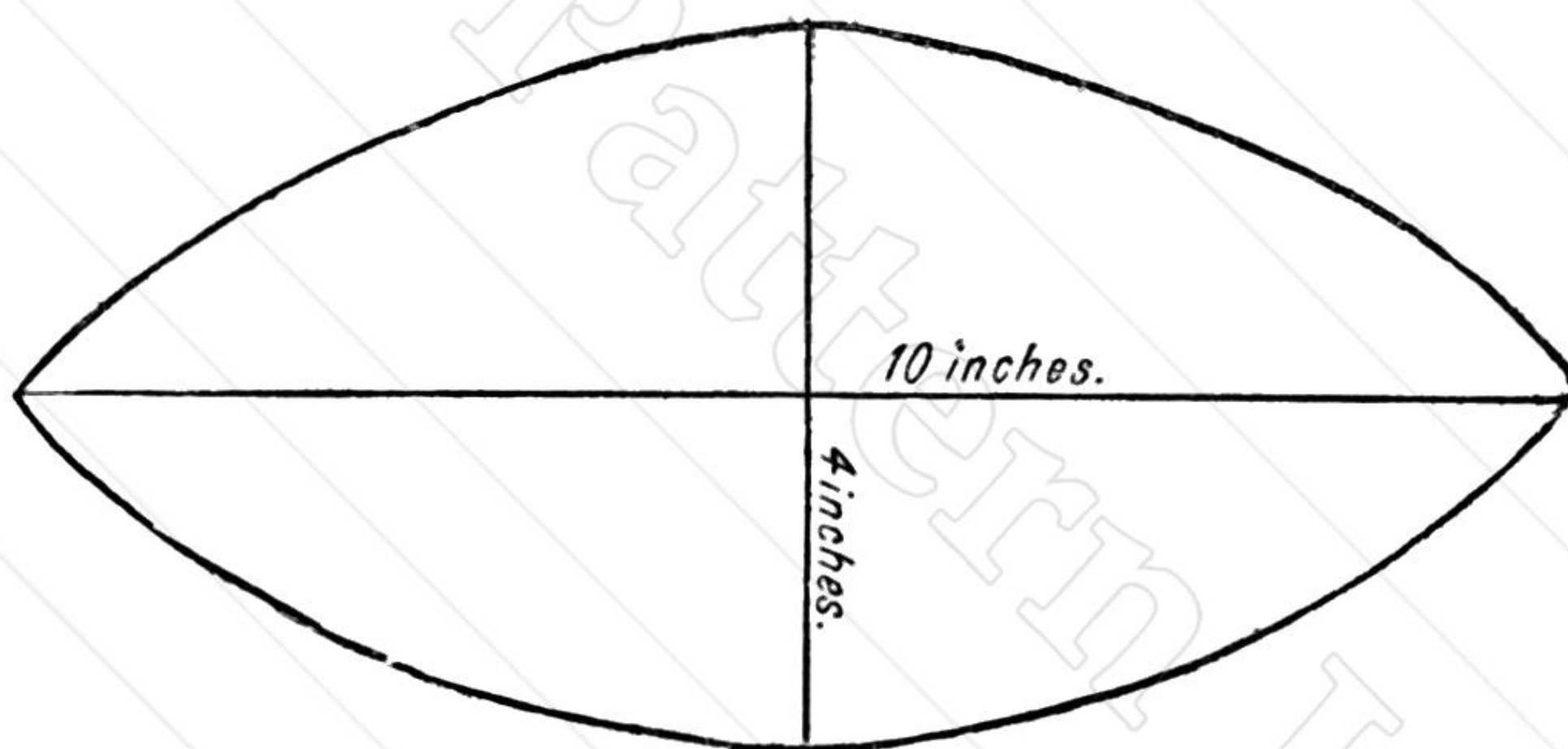

FIG. 122.

the bag together by double strings of ribbon, pulling right and left.

OCTAGONAL NEEDLE-BOOK AND HEART PIN-CUSHION

These small articles may be made with the fine pieces which will frequently come off when splitting the straw. These should be saved and kept in a separate box, and when sufficient have accumulated, small needle-books or pin-cushions should be made with them.

- Materials required.**—1. Fine straw splits, $\frac{1}{8}$ inch wide.
 2. Ordinary plaiting needle.
 3. Straw clip, 5 inches, made of strips of Mat III.

SPLIT STRAW WEAVING

147

4. Square of cardboard, 4 inches.

Method.—Two squares of weaving $3\frac{1}{2} \times 3\frac{1}{2}$ inches are needed to cut the octagons for the two covers. Interlace thirty fine cream straws in clip close together, and weave with twelve red straws the simple pattern of one up and one down. The foundation straws are kept close together, thus preventing the red from being quite pushed up, as in the previous weaving for photo frame.

Take drawing compass and geometrically describe an

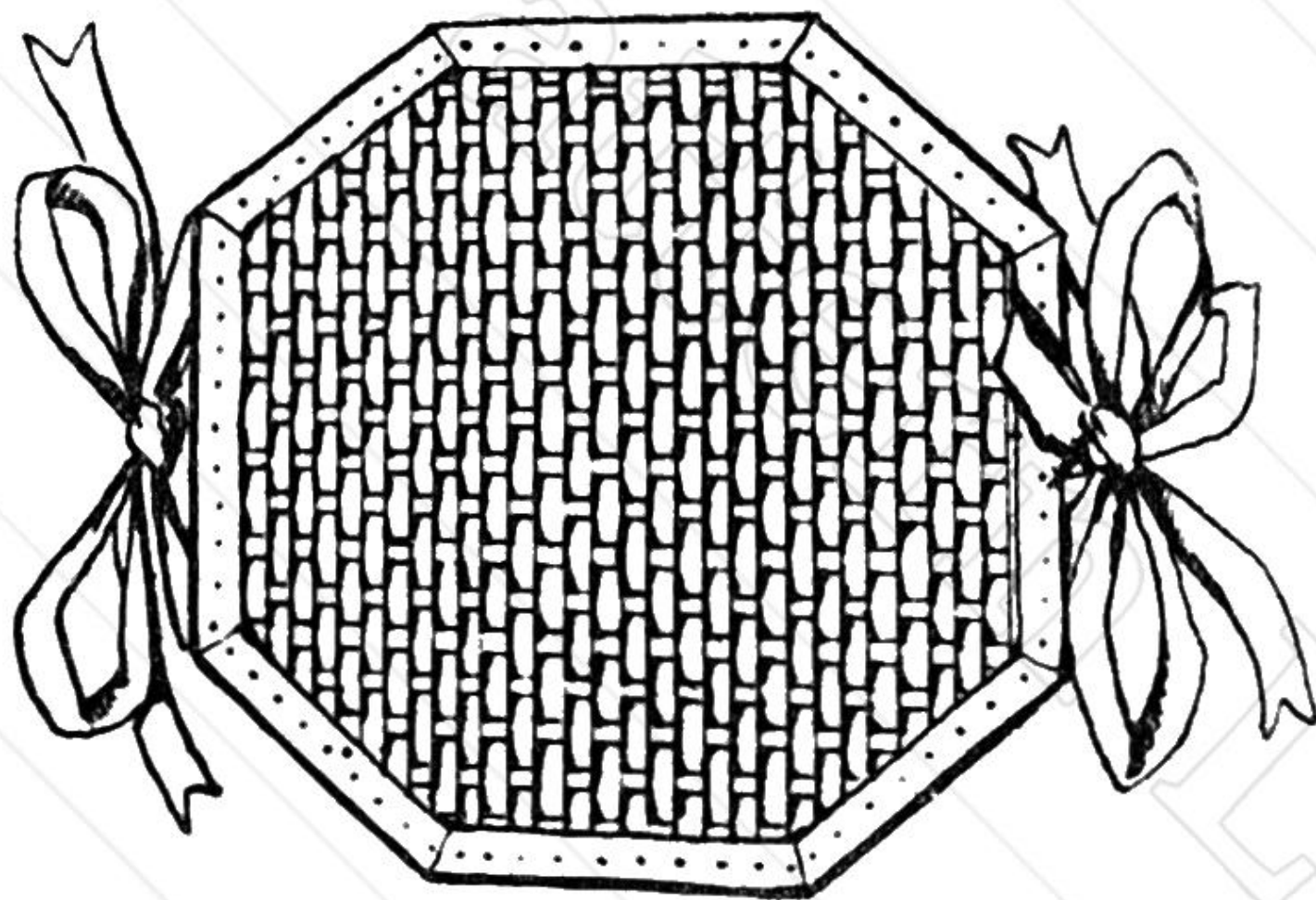

FIG. 123.—Octagonal Needle-book.

octagon of $3\frac{1}{2}$ -inch diameter. Cut two of exact size in Bristol cardboard, and paste to the wrong side of weaving. Bind the edges with narrow crimson ribbon, and cut four or six octagonal pieces of red or white flannel for the inside. Make these slightly smaller than the covers, and snip the edges. Fasten them through the back of covers with darning needle and narrow ribbon, and finish with bow.

Follow the same directions for heart pin-cushion. The two sides are laid together with a layer of flannel or cloth between. The edges are separately bound, and afterwards neatly sewn together with sewing silk of same colour as

ribbon. When finished attach small bows at top, and place pins $\frac{1}{4}$ inch apart all round the apex of heart. A child of seven years can entirely make these small articles.

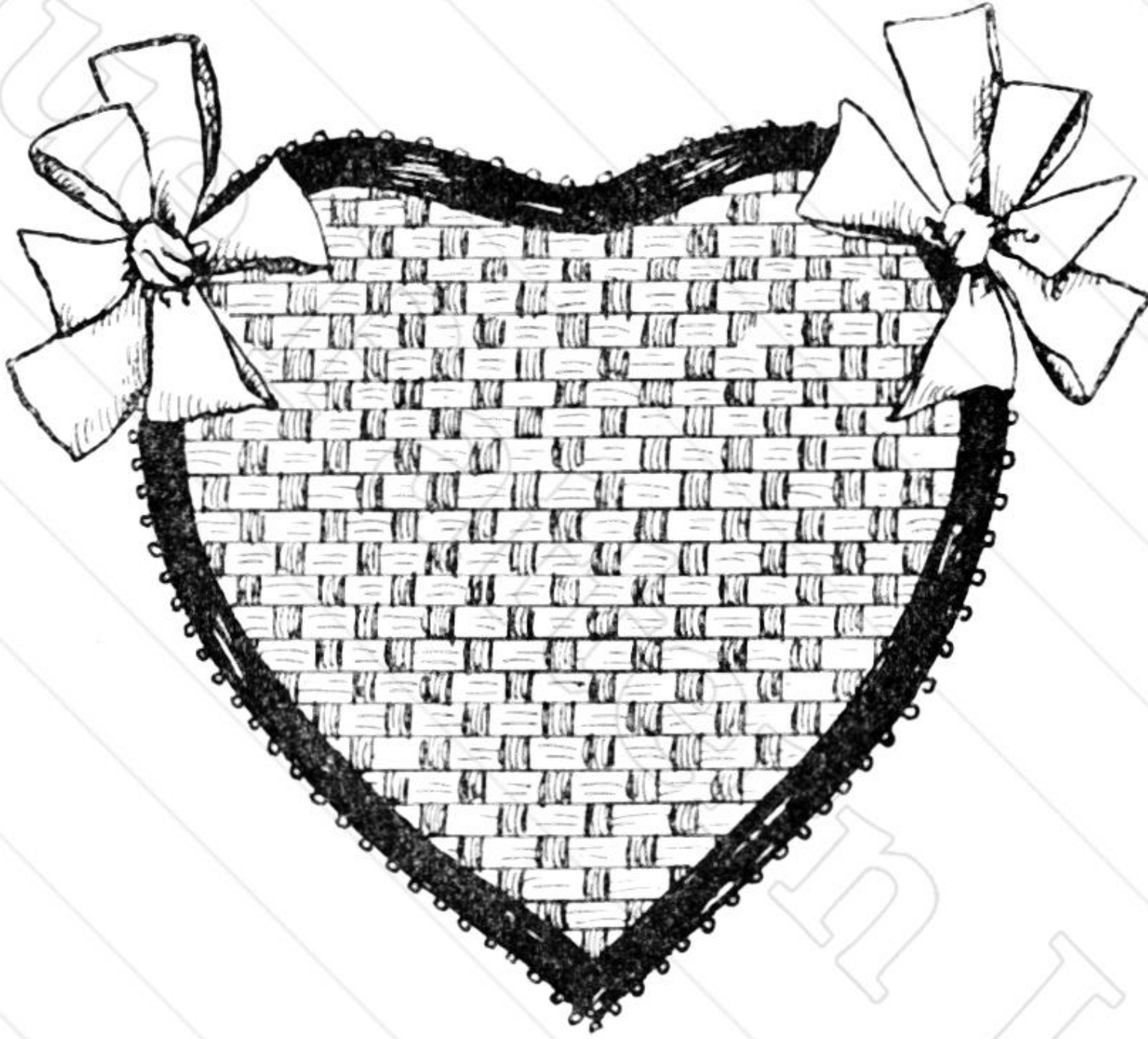

FIG. 124.—Heart Pin-cushion.

TOILET TIDY

Materials required.—1. Blue and white split straws, $\frac{1}{4}$ inch wide.

2. Clip, 11 inches wide.

3. Bristol cardboard.

4. Kindergarten steel needle.

Method.—Split all straws in half and flatten. Interlace forty-two cream straws into clip for foundation mat and interweave the blue straws according to the following pattern :—

First Row.—1 down, 3 up. Repeat to the end.

SPLIT STRAW WEAVING

149

Second Row.—Same, only begin at the *second* strip, and thus keep the pattern one strip to left.

Third Row.—Same. Begin at *third* strip.

Now reverse the pattern and begin at *second*, and then

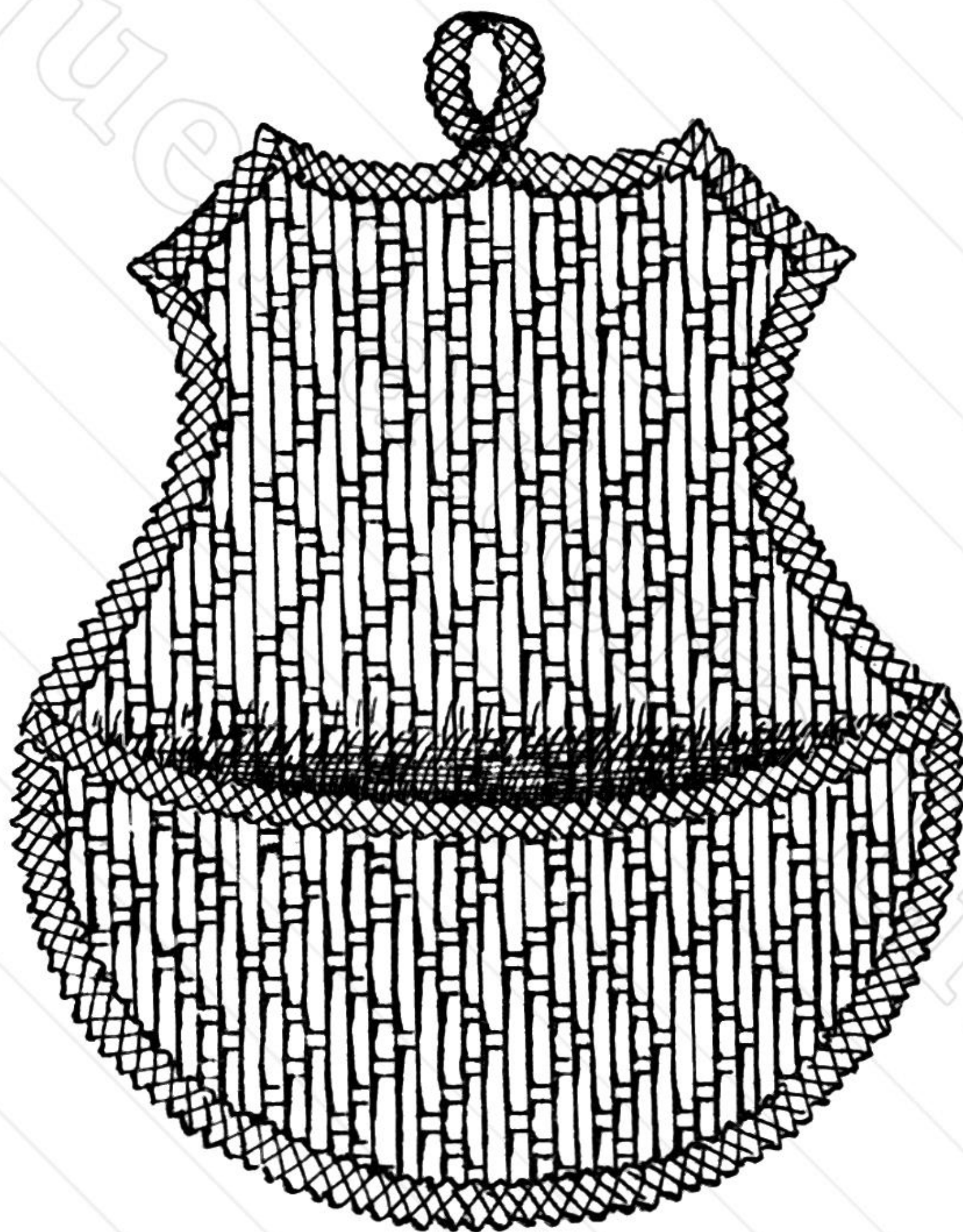

FIG. 125.—Toilet Tidy.

first again, and so continue weaving three rows to the left and three rows to the right, giving a zigzag pattern.

Weave a piece about 10 × 9 inches for the back of pocket, and another piece 10 × 5 inches for the lower portion. Cut cardboard shapes of both pieces according to the measurements given in diagram. Paste the shapes to the

wrong side of weaving and leave under a heavy weight till dry.

Cut the straw work to the shapes of both pieces.

First bind the top of lower portion with vandyke edging and cut off. Now sew the circular part to the bottom of

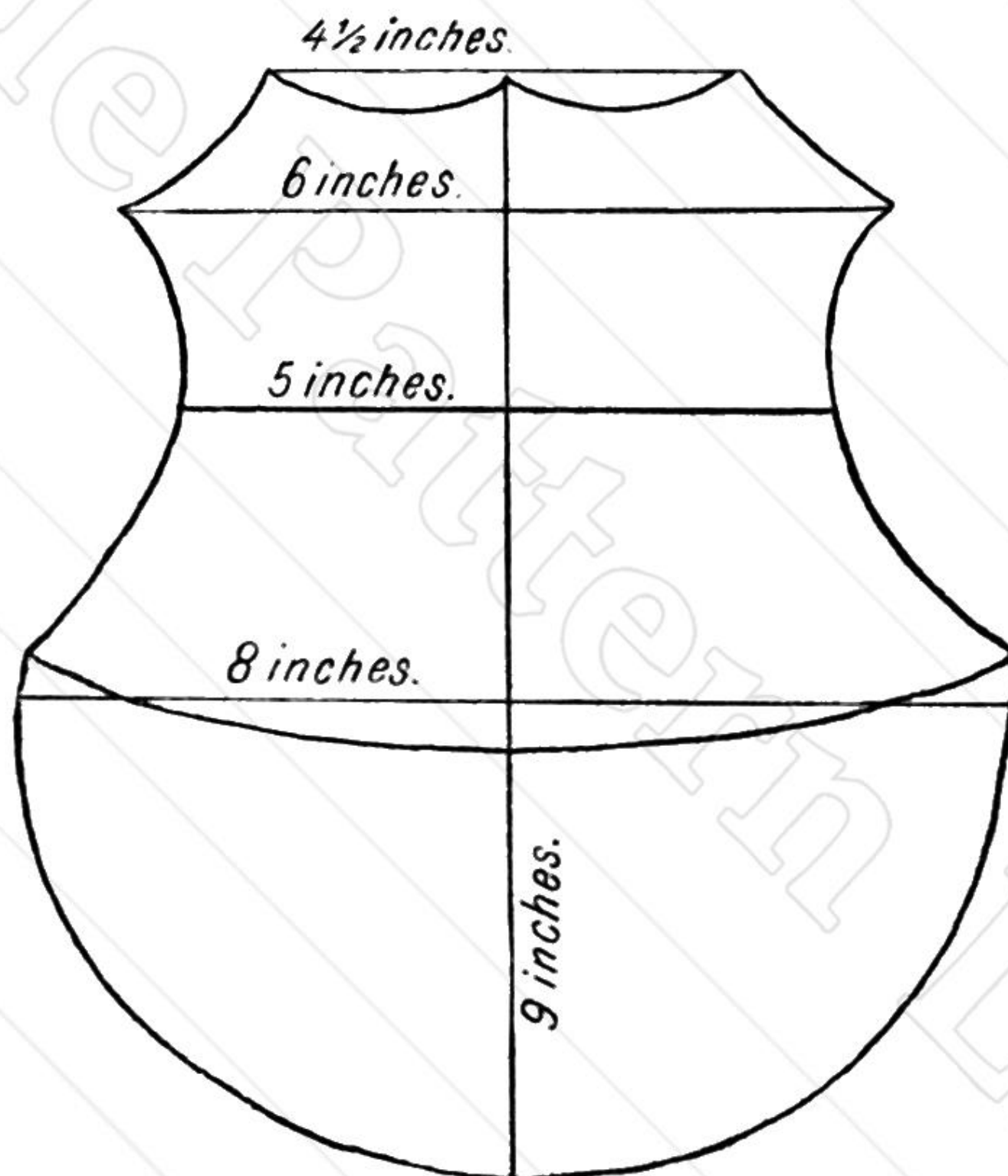

FIG. 126.

back and bind both together. Continue the edging all round and finish with loop at the top. If the cardboard is not of the best, cover it on the wrong side with coloured paper.

HAND-SCREENS

- Materials.**—1. Gold straws and gold vandyke edging.
2. Clip of 12 inches.
3. Blue straws for flowers.
4. Stout cardboard for foundation.

SPLIT STRAW WEAVING

151

Method.—The groundwork of screen looks best woven

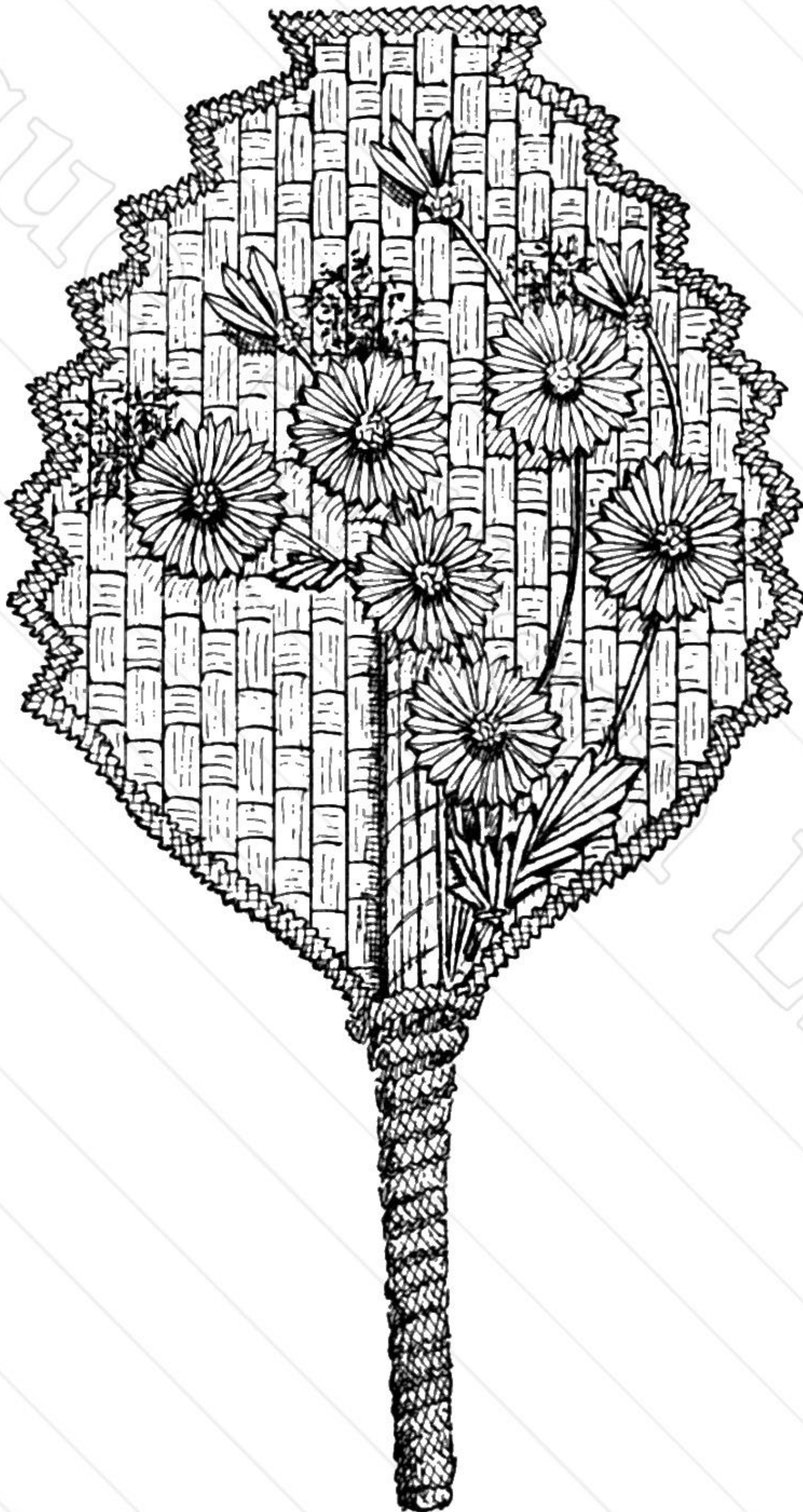

FIG. 127.—Hand-screen.

in one colour, so that the flowers form a distinct contrast.

The illustration is a gold foundation ornamented with a spray of blue flowers and buds.

Weave two oblong pieces with all gold split straws 12 inches broad and 16 inches long. Cut cardboard foundation and paste on *one* side only. When pressed and dry, cut this piece to shape, bind edge *at once* with vandyke

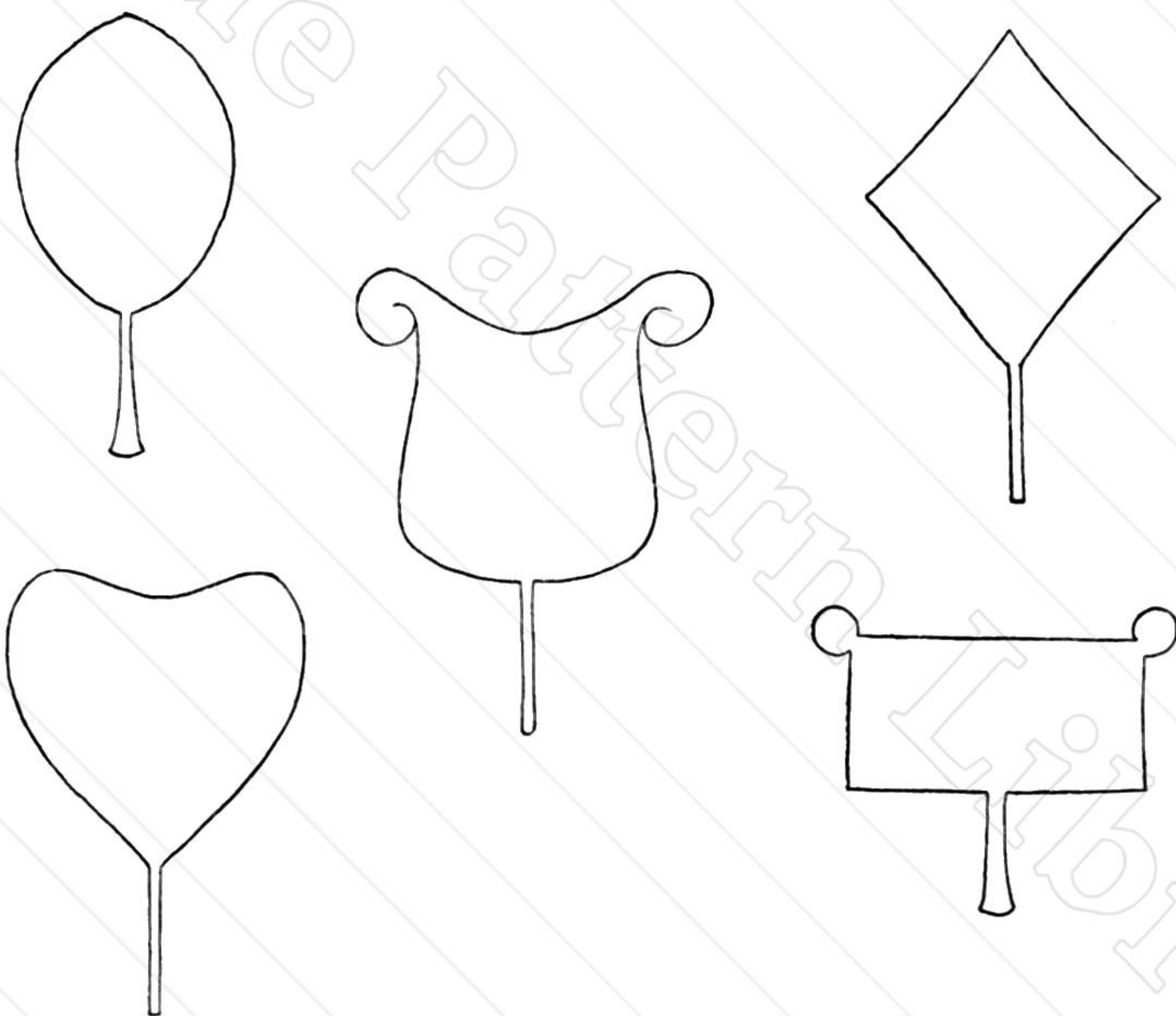

FIG. 128.—Patterns of Fans.

edging and mount the flowers in same position, as shown in Fig. 127. Then cover the back with another piece of weaving. Cut to shape and bind with vandyke edging like the front side, only omit the flowers.

Handle.—For the handle, cut two pieces of stout cardboard 12 inches long. Sew them on each side of the fan, starting from about the middle, and keep them exactly

SPLIT STRAW WEAVING

153

together, with the fan between. Fasten securely the two ends which form the handle. Now take some *whole* gold straws, press them flat and thread eight or nine together at top and bottom, and cover the cardboard handle on both sides in this manner. Wind a straw round the handle here and there to give neatness and support, and sew with needle and thread.

These hand-screens may be cut of various shapes, and all are suitable for the work, and the directions given are applicable to all.

FLOWERS

How to Make.—Many cuttings from the work will be found useful for making flowers. Any split pieces of 2 inches in length will do.

The straws are better a little damp for this purpose, so roll the bits in a wet towel over night, or allow a little water in a tin saucer to moisten the fingers. If the straws are not exceptionally stiff and brittle, simply breathing on the unglazed side will be sufficient.

Take a straw 2 inches long and $\frac{1}{4}$ inch wide. Double in half. Open. Place forefinger of left hand on crease of



FIG. 129.—Flower.

centre and make oblique crease with right-hand end, thus :—

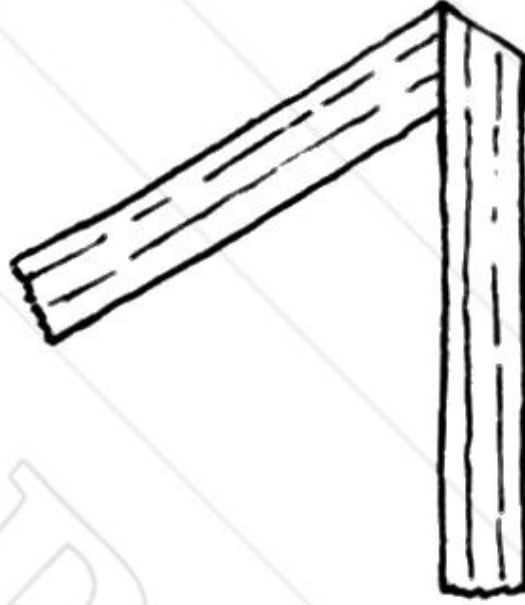

FIG. 130 (1).

Take left-hand end and fold down in similar manner to touch right, thus :—



FIG. 131 (2).

This is one petal of the flower. About twenty or more of these are required according to the size of flower to be made. When a sufficient number for flowers are folded, provide each child with a needle and waxed thread, and a small square of stout brown paper, not easily torn.

The two ends of each petal are *crossed* just at the extremity and threaded carefully on the needle, *four* only at one time. As each four are threaded they must be sewn on to the small cardboard disc, and radiated regularly, as in Fig. 133 (4). The small space in centre is filled by a

SPLIT STRAW WEAVING

155

crumpled straw of another colour—in this case gold—to match the foundation colour of screen.

Buds need only two or four petals, according to the size, and are finished off by a cross straw, with the ends turned underneath.



FIG. 132 (3).



FIG. 133 (4).

Stems.—Whole straws are used for stems, of same colour as the petals. To make them bend in position, a fine wire is passed up inside the straw and bent into shape, after which the stem is sewn to the foundation. A little fine artificial grass, sewn on with the flowers, adds much to the beauty of the screen and removes the hardness which the flowers otherwise present.

A pliable strip of straw is easily threaded in a darning-needle and sewn through the weaving in long stitches to represent leaves. See leaf in Fig. 127, near handle.

SIMPLE FLOWERS

An easy way of making flowers is the following:—

Give the children split half straws about a quarter inch wide. The straws need to be damp for creasing, or a small tin of water might be provided for each dual desk, in which the children can moisten their fingers.

Take the moistened straw and crease it at distances of $\frac{3}{4}$

inch, always keeping the glazed side of the straw uppermost. Thread the alternate points on a sewing needle and stitch to a small circular foundation as before described for other flowers. Flowers may be used to ornament the top cover of blotters, or the front of toilet tidies and pockets. It is



FIG. 134.—Simple Flowers.

best to let the children practise making these flowers with the paper-weaving strips, and the result will be charming, and the paper flowers can be utilised for paper decoration.

FANCY TABLES AND STANDS

Materials required.—1. Green and gold straws.

2. Green and gold straw plait.

3. Green and gold ball fringe.

4. Pale green or yellow enamel.

5. Brass-headed nails or gilt-headed tin tacks.

Straw work is very suitable for the decoration of plain



FIG. 135.—Fancy Table and Stands.

wooden articles, and nowadays, when so many cheap and artistic articles in plain wood are to be had, perhaps it would be as well to describe how the work may be utilised. The sketch shows a pretty wood table which can be bought at any fancy depository in extensive variety. The first thing to do is to enamel the table. This part may be done quite well by the children under the superintendence of the teacher. Painting and gumming are two occupations much enjoyed by children.

Of course the colour of the enamel must harmonise with the colours used in the straw weaving. Each tiny circle is covered with the weaving, which may be glued on with thin glue, or tacked on with small tacks. Each circle is then finished with ball fringe, made with the same colours, green and gold, to match the colours of the straw. When this is done, ornament the edges by a broad straw vandyke plait and fasten the same on with small brass-headed nails.

The balls for the fringe may be made by the lower infants and crocheted together by the teacher.

The centre column and legs may be ornamented with bows of ribbon or a spiral twist of the straw plait, as in Fig. 135.

The work is very effective, and has almost the appearance of inlaid Japanese work, and the stand will be found useful for holding books, small pots of ferns, or vases of flowers, photo frames, etc. It takes up little space and may be placed in the corner of any room. Gipsy tables, milk stools, music stands, etc., can be so ornamented.

Note.—A pleasing variety to this work is made by substituting coloured ribbons for the foundation, arranged as directed in "Ribbon Weaving." The straws are interlaced with the glazed side downwards, and the work pasted to the foundation before it is removed from the board. This work can be folded and ladies' music and work cases made of it.

STRAW WEAVING

159

STRAW WORK

OXFORD PICTURE FRAME

- Materials required.**—1. Whole straws, 12 inches long.
2. Needle and cotton.
3. Two yards of ribbon, $\frac{1}{2}$ inch wide.

Method.—Take an uneven number of straws, 3, 5, 7, or 9, according to the width required, and lay them side by side, even at the top and bottom. With a long straw needle thread through the whole number about two inches from the end. Pass the needle back again a little lower down and pull the straws close together and fasten off. Do the same at the lower end of the straws and then cut to shape. The ends may be cut straight, pointed, oblique, or scooped out like the tail of a fish. Each of the four sides must be made in the same way, after which they are crossed and sewn at the corners and tied with bows of ribbon. The children like making these frames, and they are very useful for framing specimens of their work, and make a goodly show hung on the class room walls on examination day. Attach a small loop of ribbon at the back to suspend the picture frame.

STRAW PLAIT WEAVING

This occupation is an inexpensive one, yet very useful and simple to do. The straw plait is sold in bundles of 60 yards at 6d. per bundle, and may be obtained in various

colours and mixtures, and of different widths, of Mr. W. Higgins, Luton.

The vandyke edging, which is most suitable for finishing off an article rather than for weaving, is plaited according to the rules given under "Paper Plaiting," and could be taken as a separate occupation. This plait is also sold in plain white and mixtures at 1s. for 20 yards.

Besides weaving entire articles with straw plait, it is very useful to introduce into the cane-weaving articles, and a few rows at intervals will very much enhance the appearance of an ordinary cane basket.

The plait may be cut in lengths, and fixed upon the points of a weaving frame, or wound to and fro round short nails on a slate frame, or fixed in two clips, as in "Straw Weaving," according to the size of the piece of work required.

DINNER MAT

Materials required.—1. Oblong frame, with nails 1 inch apart.

2. Straw plait, crimson mixture, $\frac{3}{4}$ inch wide.

3. Needle and thread.

4. Crimson vandyke edging.

Plan of Lesson.—Dinner mats of any size or shape may be made in this way. Wind the plait the long way of frame, as described in "String Work," and weave across separate lengths of the plait. Tack the work all round the edges before removing from the frame. The work will be sufficiently firm and will need no mounting. The edges must be bound with narrow braid or a strip of American cloth, and then over the stitches sew a vandyke edging on both sides. The pieces for dinner mats are easily convertible

into many pretty, fancy baskets, such as the following shapes. Separate pieces as circles, half-circles, and oblongs must be woven and cut to shape for the sides, then bound round and sewn in.

HAND BASKET

This hand basket is made of a red mixture of straw

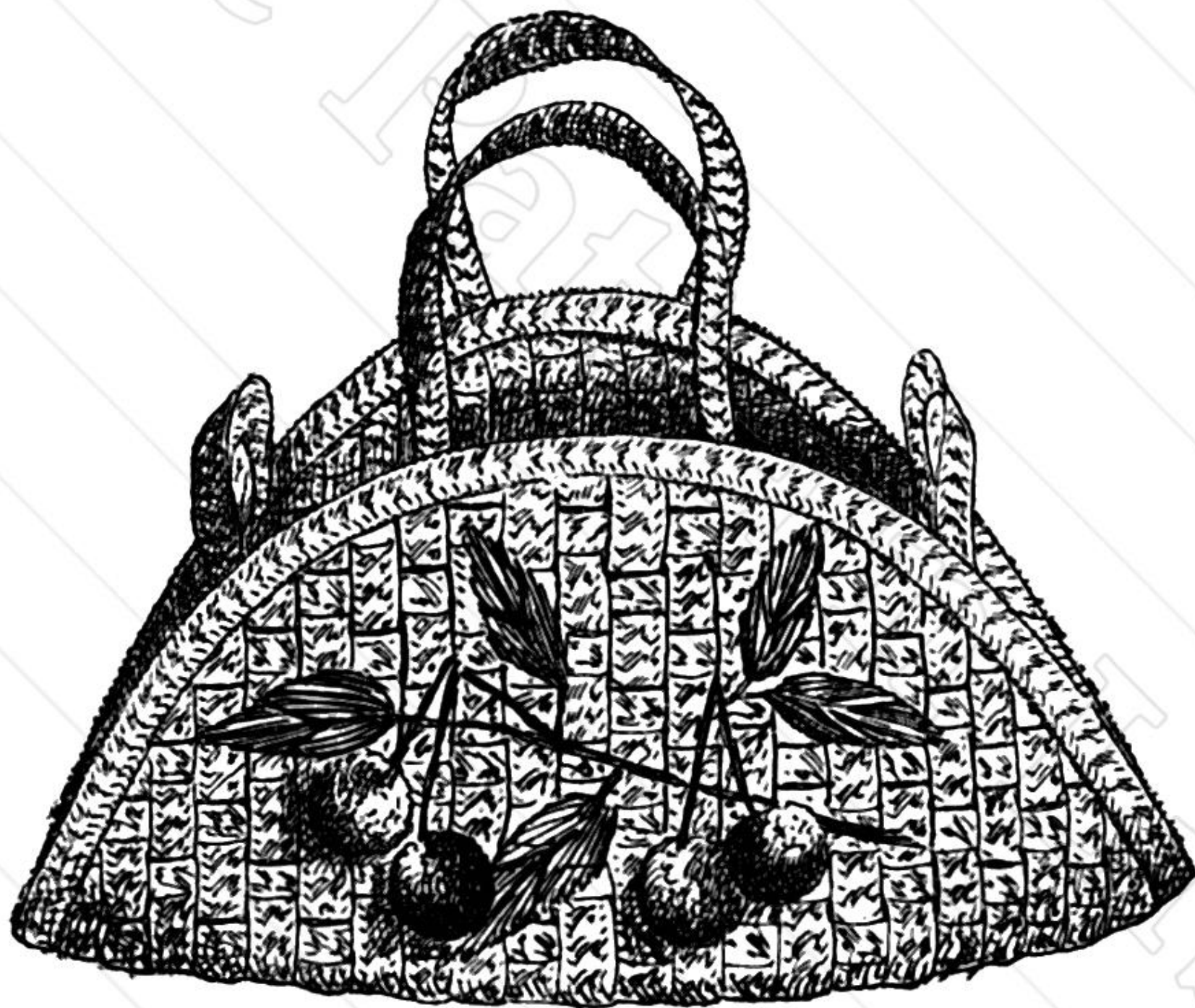

FIG. 136.—Hand Basket.

plait about *three-quarters of an inch* wide. The plait is cut into lengths *16 inches* long, and fixed upon the points of the weaving frame. Shorter lengths of *11 inches* are then woven across, and from this piece of weaving an oval mat $16 \times 10\frac{1}{2}$ inches is made. The ends of the mat are secured between a double binding of the plait, which is sewn round the edge on both sides.

These bags, if woven in plain white plait, may be much

improved by ornamenting the right side with a worked spray of wool flowers or the word "LONDON."

Method.—Before removing the piece from frame, tack upon the weaving a simple outline drawing of leaves and flowers or fruit. The drawing may be on cartridge paper and tacked in position with needle and thread. The child will fill the shape of leaves in with long wool stitches, and with a lighter shade of wool mark in the midrib and veins of leaf. Fig. 136 shows a cluster of cherries which are produced from the ball-making class. They are in various shades of red according to their degree of ripeness, and are caught down to basket. The stem is brown, and worked in a kind of back stitch. This embroidery is best done on the frame and the needle passed through the weaving up and down. When finished tear away the paper drawing, remove the work from frame and finish basket to the required shape.

Two oblong pieces are woven and cut to shape for the sides, and the bag finished with two handles made of double pieces of plait.

These baskets are easily made and varied in shape. A straight oblong piece can be rolled round with two circles for the ends, and thus a music case or lady's knitting basket may be made. The upper flap fastens over upon the under one with two buttons and elastic loops.

The basket in Fig. 136 could be made with straight sides instead of round.

STRAW PLAIT WORK

LETTER-MAKING

To prevent waste of material, which must occur if the short lengths and cuttings be not used, the following plan

STRAW PLAIT WORK

163

will be found advantageous for using up such pieces, and the occupation might form a very suitable one for a lower class : —

- Materials required.**—1. Hektograph copy of letter.
 2. Piece of ribbon wire.
 3. Length of straw plait.
 4. Needle and cotton and paper scissors.

Method of Lesson.—Distribute to the class a hektograph copy of the letter to be made, *e.g.* “S,” and the paper upon which it is printed should be stout and untearable, such as cartridge or brown paper. Question upon the letter, its shape, etc., and distribute to each child a length of wire which should exactly correspond in length to the curve of the letter. The letter should have been measured beforehand by the teacher and the wire cut accordingly. The children now bend the wire to the shape of the letter, and when *exact* and examined by the teacher, the children sew the wire letter upon the hektograph copy with needle and cotton. They sew over the wire each time till the letter is firmly secured.

Paper scissors are distributed to the satisfactory ones, and the outline of the letter cut from the paper with a margin of $\frac{1}{4}$ inch on each side of the wire. The paper keeps the wire in shape, which is impossible to alter if sewn securely. To these foundations a piece of straw plait is sewn and the ends turned in neatly and fastened off. Sew the plait to the paper each side of the wire.

The letters most suitable for making are: I, L, V, U, Z, W, C, O, S, M, N, D, P, J, which can be made from one straight piece of wire and plait, the other letters need pieces added.

Use.—These large letters look very nice, and if mounted upon square cards may be used in the babies' room for

Kindergarten games. Each child could have one suspended

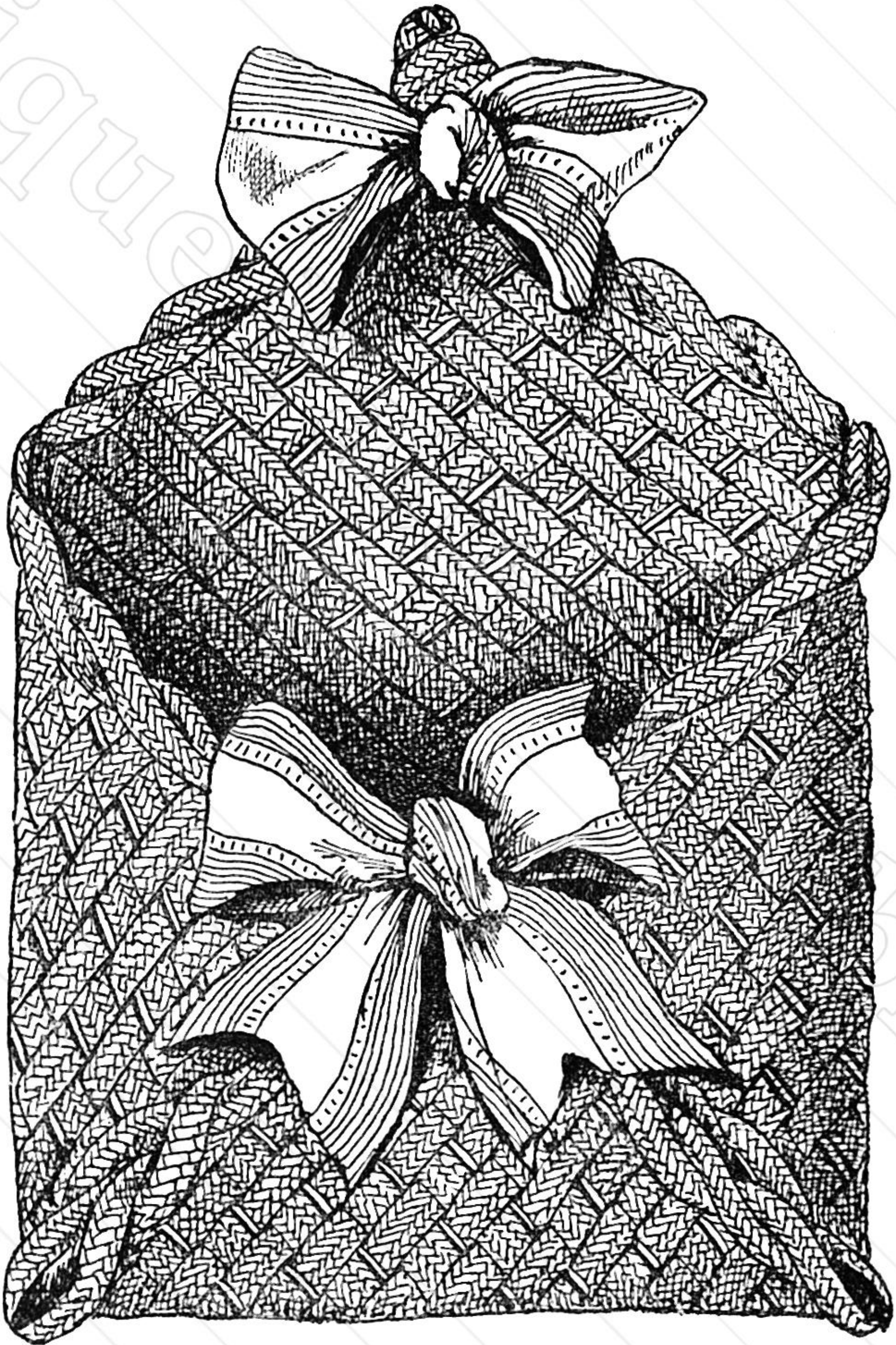

FIG. 137.—Wall Pocket.

on its neck, and the children could be named according to

STRAW PLAIT WORK

165

their letter and answer to the dictation of the teacher. Word-building might also be made with them. They also look well made into texts or mottoes to be hung on the walls.

WALL POCKET

Materials required.—1. A square frame, with nails $\frac{1}{2}$ inch apart.

2. Macramé string, straw plait, blue and yellow, $\frac{3}{8}$ inch wide.

3. Yellow ribbon, 2 inches wide.

Plan of Lesson.—Wind the straw plait continuously up and down upon the nails, as described in “Ribbon Weaving.” This will represent a tight mat. Cut the weaving plait in lengths and interlace across, one over and one under. In Fig. 137 a yellow strand of Macramé twine is woven in with the plait and much improves the appearance. The colour of plait is blue and yellow. A square of 12 inches is required for this pocket. When the weaving is complete, tack the weaving ends to the side strands of mat. Next snip the loops round nails and also tack these securely. Finish the square with a twisted binding on both sides. Turn up three corners and catch together and finish with a large bow of yellow ribbon, and add another bow at the top corner. Form a loop with the plait when binding to suspend it. These pockets are made in pairs.

HANDBAG

Materials required.—1. Straw plait, plain or mixed, at 6d. per bundle of 60 yards.

2. A wooden box about 3 inches deep and 11 inches long and 8 inches wide.

3. Needle and cotton.

Plan of Lesson.—Boxes suitable for the foundation are the wooden chocolate and sweet boxes, which may readily be obtained by the asking for at any Italian warehouse. The straw plait can be bought in very pretty mixtures of red and cream, blue and cream, brown and



FIG. 188.—Handbag.

cream, blue and brown, etc., or in the plain colours of white, blue, brown, and marone.

Begin at one corner of the box and secure the end of straw plait with a drawing pin, well forced in. Let the child now wind the plait evenly round the box to the depth of 6 or 7 inches. The plait must not be pulled too tightly, but left sufficiently slack to allow for the transverse weaving. Cut off the plait and secure the end with another drawing pin. The weaving will be found easier to do if

STRAW PLAIT WORK

only the sides of the box be used, and the top and bottom broken away.

Next cut several lengths of the plait for the weaving strands. These must be long enough to reach entirely round from the top strand on one side to the top strand on the opposite side. They are best cut a little longer than

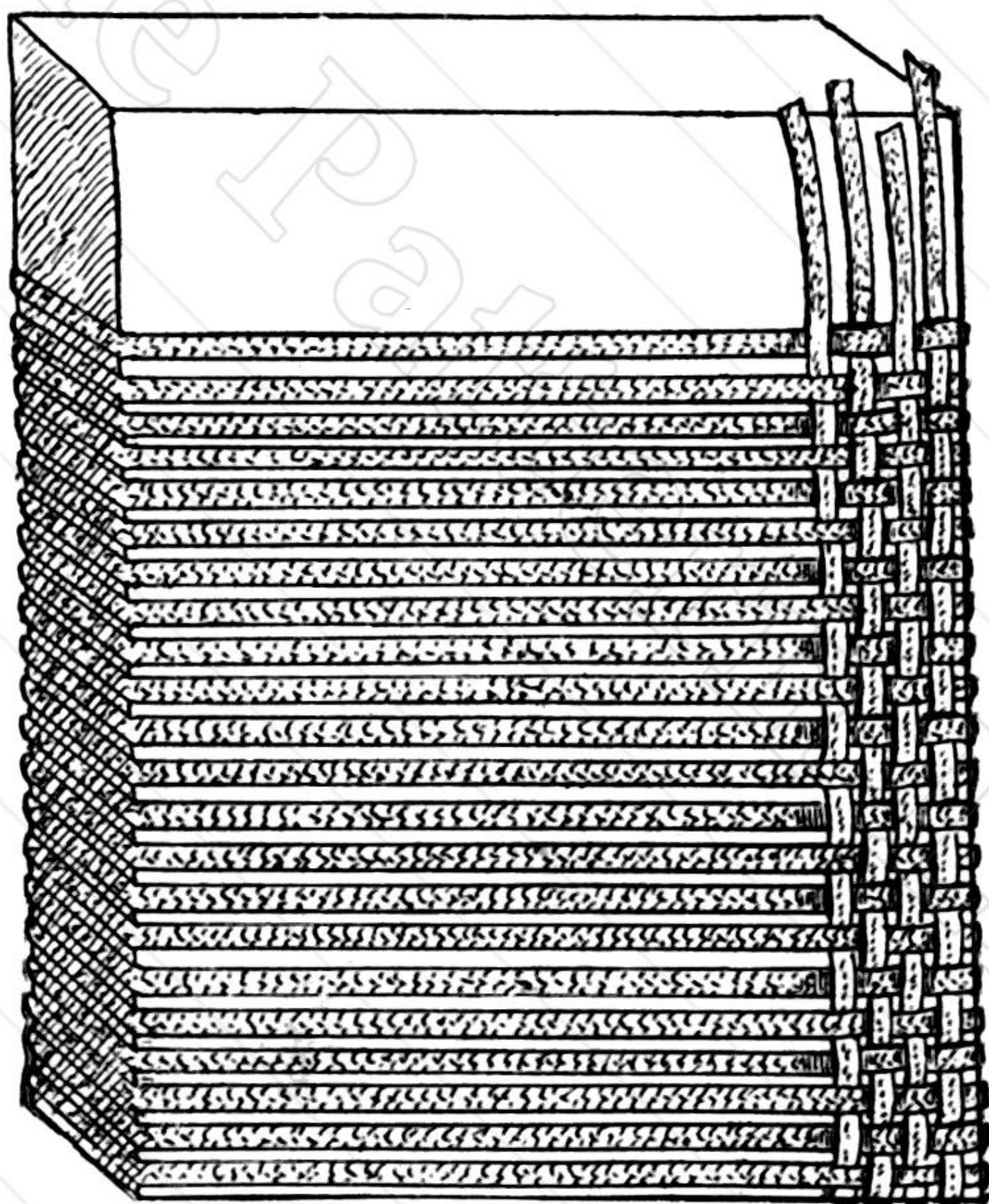

FIG. 189.

required, and will then need no fastening at the ends whilst they are being woven.

The weaving is first carried down one wide side, across the bottom and up the other wide side. This done, it is next woven up the narrow side of box, across the bottom and up the other narrow side, which completes the weaving.

Finishing off.—Slip the box out of the weaving, and with needle and thread secure the ends neatly—first the two ends of the foundation plait, and lastly the weaving ends. These should be sewn to the top round, and then cut off close. To finish neatly, a piece of plait is sewn round the top on the inside and another piece outside. By this arrangement, all the ends are secured and hidden between the outer and inner bindings.

Handles.—Stitch two pieces of plait together for the handles and sew one handle on each side. Insert the ends into the weaving, and strongly sew in place with the needle and thread. A cover to overlap and button with loop is easily made by cutting the weaving strips 6 inches longer than required for open basket. Make the basket exactly in the same way, and let the 6 inches extend on one side only. When the basket is complete in weaving, as before described, then *flatly* weave to and fro the strands left on one side. Secure the ends and bind in similar way with the double plait. Turn the flap over to the front and finish with two buttons and loops of elastic.

HANDKERCHIEF AND GLOVE BOX

Materials required.—1. Square and oblong cardboard boxes.

2. Fine straw plait, $\frac{3}{8}$ inch wide, crimson mixture.
3. Ribbon, 1 inch wide, to match.
4. Crimson sarcenet for lining.

Plan of Lesson.—Cardboard boxes of all shapes and sizes may be utilised for this work. That in Fig. 140 is an ordinary cardboard glove box, begged from the drapers. The plan of making is very similar to that of handbag, with this difference, that the box is *entirely* wound

STRAW PLAIT WORK

169

and covered with weaving. Begin at corner and wind round the entire box one way, rather loosely. Secure the ends. Cut lengths of plait to measure round the reverse



FIG. 140.—Handkerchief and Glove Box.

way. Weave these in, beginning always at the right or left side of the top of the box. The reason for this is, that

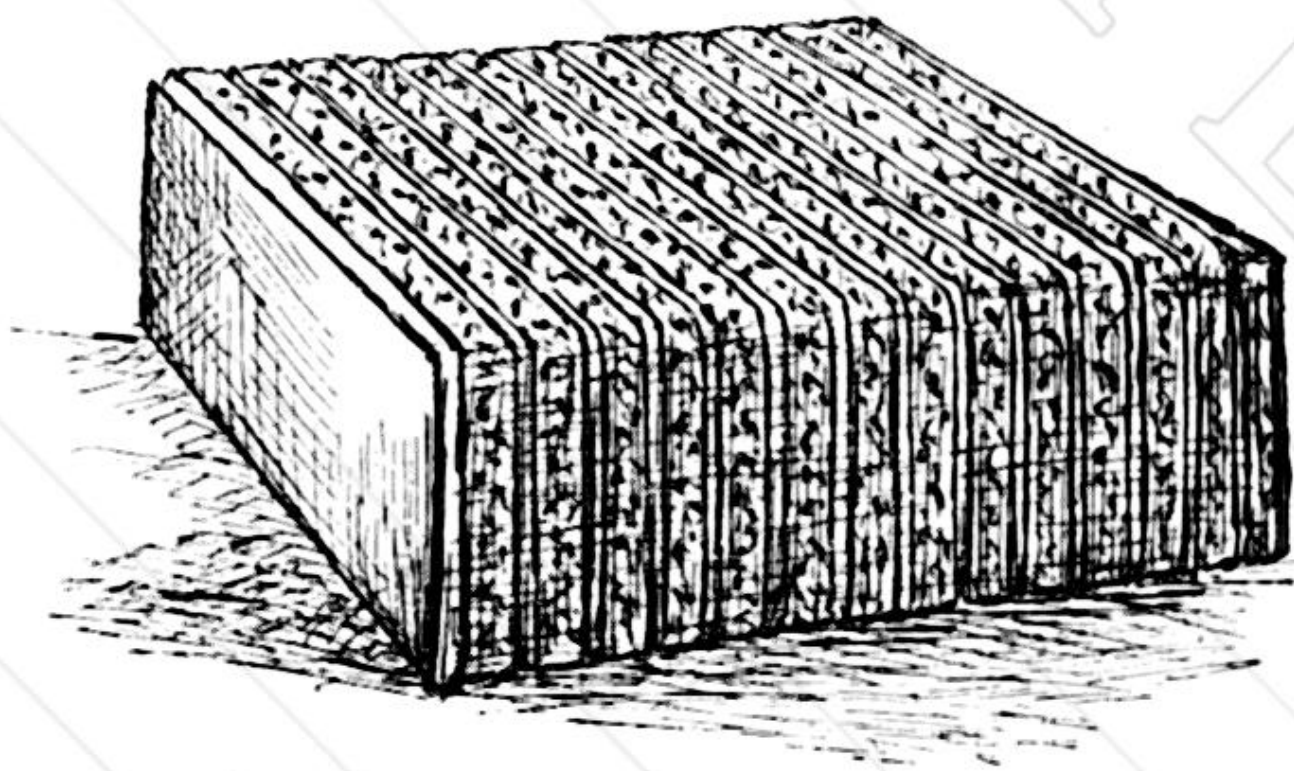

FIG. 141.

the weaving will have to be cut on two sides for the lid of box to open, and therefore the beginning and ending of the plait will come at one side of the lid.

When the entire box is covered in weaving, snip very carefully the plait at the edges where the lid is to open.

One side of the weaving must be left intact to form the hinge.¹ Then sew the plait to the cardboard foundation, and line inside with gathered silk, and finish the outer edge with a twist of the plait which must overlap the weaving so that the cover closely fits. Attach ribbon to the lid and front of box, to tie together, and place a smart bow on the top for ornamentation.

Any kind of shape may be covered and woven in this

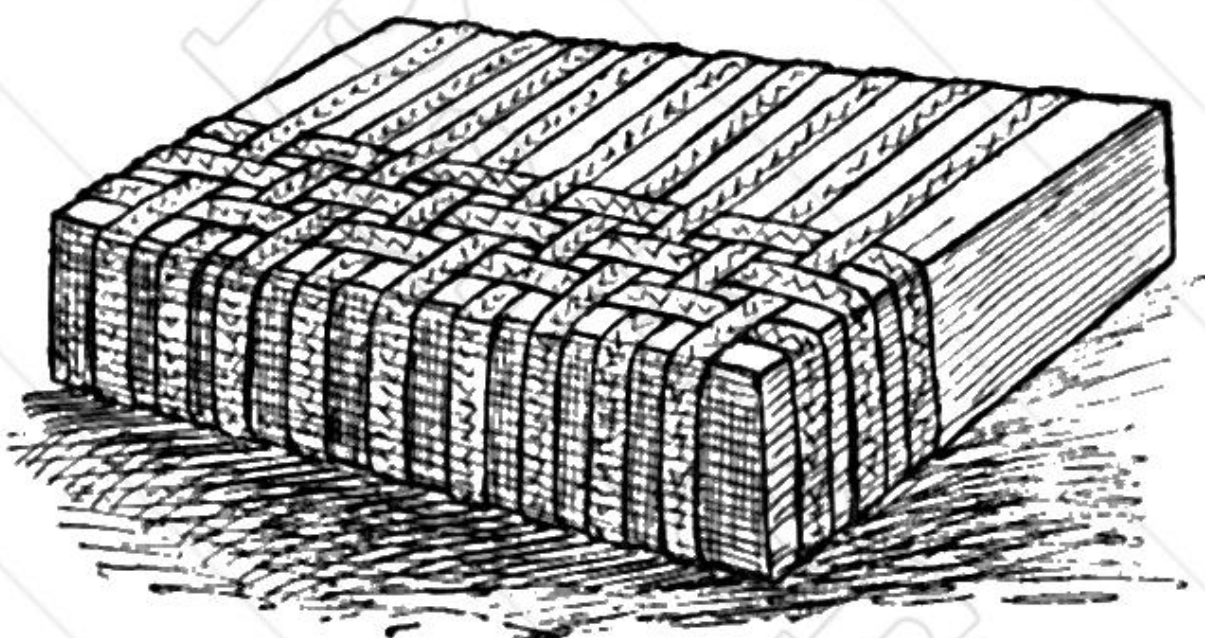

FIG. 142.

way. Some as open work-baskets and others as flat covered baskets, which are most useful to hold ladies' ribbons, ties, etc. The straw plait is now manufactured in such endless variety, that no difficulty should be found for producing most artistic, cheap, and useful work.

CANE WEAVING

General Description.—There are few occupations for boys so easy, useful, and attractive as cane weaving. It gives them endless pleasure, especially when they are able to weave various articles. Its educational value in training the hand and eye cannot be equalled in any other occupa-

¹ The cardboard lid should have been loosely attached to the box and the rim cut off before the weaving was commenced.

CANE WEAVING

171

tion, whilst the faculties of form and judgment are most fully exercised and developed. Parents are pleased with the work because it is *useful*, and many instances occur in which the children make articles at home, and compete at Bands of Hope for prizes, etc.

The material used is inexpensive, and repays its cost in the sale of the useful articles made.

The occupation is clean, and of little trouble, and one which can be taken easily by a class of thirty boys.

Method of Teaching.—The children who enter upon this occupation should have had practical instruction in mat-weaving, and thus be competent to follow the directions of the teacher. The best method of teaching this subject, is to start the whole class at the work, and at the *same stage* of the work, step by step, until the weaving is thoroughly understood. About half the year should be spent in this simultaneous teaching, and by that time the majority will have become proficient and capable of constructing an entire basket themselves.

Teachers who are ignorant of the subject cannot fail to attain success, if they will follow the instructions laid down in these articles, and work each exercise themselves, and find its difficulties and how best to cope with them *before* attempting to teach the children. No doubt, at first, to an unskilled hand, the cane will seem an unmanageable item, but with a little tact, *which can only be gained by practical work*, it will become as easy of manipulation as a length of string.

Material.—The cane used is round French cane of various sizes, viz. 00, 0, 1, 2, 3, 4, 5, and 6.

The first sizes are the finest, and suitable for beginners, and the making of small articles.

It is always advisable to use a size coarser for the founda-

tion strands than that used for weaving, so as to give firmness to the work.

Nos. 3 and 4 are good for foundations.

The cane, prepared ready for use, may be obtained in bundles from any Kindergarten depôt, and varies in price according to the size from 1s. to 2s. a lb. for the finest quality.

There is a mistaken idea that small dolls' articles are easier to make than larger ones. As far as plain, flat articles are concerned, this may be true, but practical experience has proved the opposite, for the smaller the article the more difficult it is to weave and make a good shape.

A large article needs more foundation strands, and coarser cane, but the weaving is easier and less difficult to keep in good shape.

It is well to present only one difficulty at a time to children, and for them to master that one before attempting another. Therefore this book is graded upon that principle and will treat of—

1. Horizontal cane weaving on a frame.
2. Flat circular weaving.
3. Upright circular weaving.
4. Flat and upright circular weaving combined.

HORIZONTAL CANE WEAVING

WASHSTAND SPLASHER

Introduction.—As the children will have already had experience in weaving upon a frame, it is advisable to let them have a little practice of using cane before they learn

HORIZONTAL CANE WEAVING

173

circular weaving. The weaving frame used for string or old slate frames are both suitable for the work, and the great regularity and firmness make it valuable for useful articles. Square pieces may be bent into envelope wall pockets, or square baskets with the points turned backwards. The same piece may be rolled round, and two circular mats added at each end to form a music case, or knitting basket. Various shapes may be manipulated by soaking thoroughly the piece of weaving in hot water, and then bending and tying in shape and left till dry.

Size.—Splasher, 36 × 20 inches wide.

Materials required.—1. Coarse cane, No. 6.

2. Wooden frame, 36 × 18 inches wide.

Plan.—An old picture frame stretcher answers well for the frame. Insert into the long sides of the frame short French nails $1\frac{1}{2}$ inches apart. Thoroughly soak the cane and wind it backwards and forwards across the frame and round the nails, as shown in "String Frame," Fig. 67. See that the strands are straight and that the end ones are secure and firm; it is best to have the end strands double, because the weaving thread is turned back upon these and strength is needed to keep them straight and firm. A round blind stick at each end will answer the purpose better still.

The weaving is very simple, just over and under, as in ordinary mat-plaiting, turning round at each end and weaving back again. If the length is not sufficient to finish a row, it should be cut off at the end of the preceding row and another length begun; no joins are then visible anywhere. When the weaving is of the size required, slip off the loops from the nails, splice all ends neatly, and finish both sides by first sizing and then enamelling in red or any other colour. These splashes are most durable and may

be washed and used for years; they are easily made by children of six and seven years of age.

DOUBLE FERN POCKET

Material required.—No. 1 cane.

Method.—This pocket is made from an oblong piece of weaving which is woven on the weaving frame described under “String Plaiting.” The cane is wound up and down upon the *thirty-eight points*, and long lengths of cane are woven backwards and forwards until the length is used up. It is better to begin a new length at the beginning of a row rather than in the middle. The point of difficulty in this frame weaving is the turning back of the cane at each end of the frame, where it is liable to be irregular. To avoid this a stout strand of cane should be added at each end upon which to turn the weaving thread. When the frame is full and the piece measures $18 \times 10\frac{1}{2}$ inches, remove it from the frame and plunge it into warm water. When sufficiently soaked take the two lower corners and curl upwards and inwards to form two pockets as shown in Fig. 143, tie in position, and leave to dry. Secure the pockets together by threading in and out a fine length of cane from the back. Varnish thoroughly and mount the pocket upon an oblong mount of stout cardboard covered with plush or velveteen. Add bows of ribbon top and bottom in harmony with colour of mount. The pocket is useful for artificial grasses or ferns.

BASKET WEAVING

Directions to be followed.—The following points must be borne in mind and carried out, if the teaching is to be successful :—

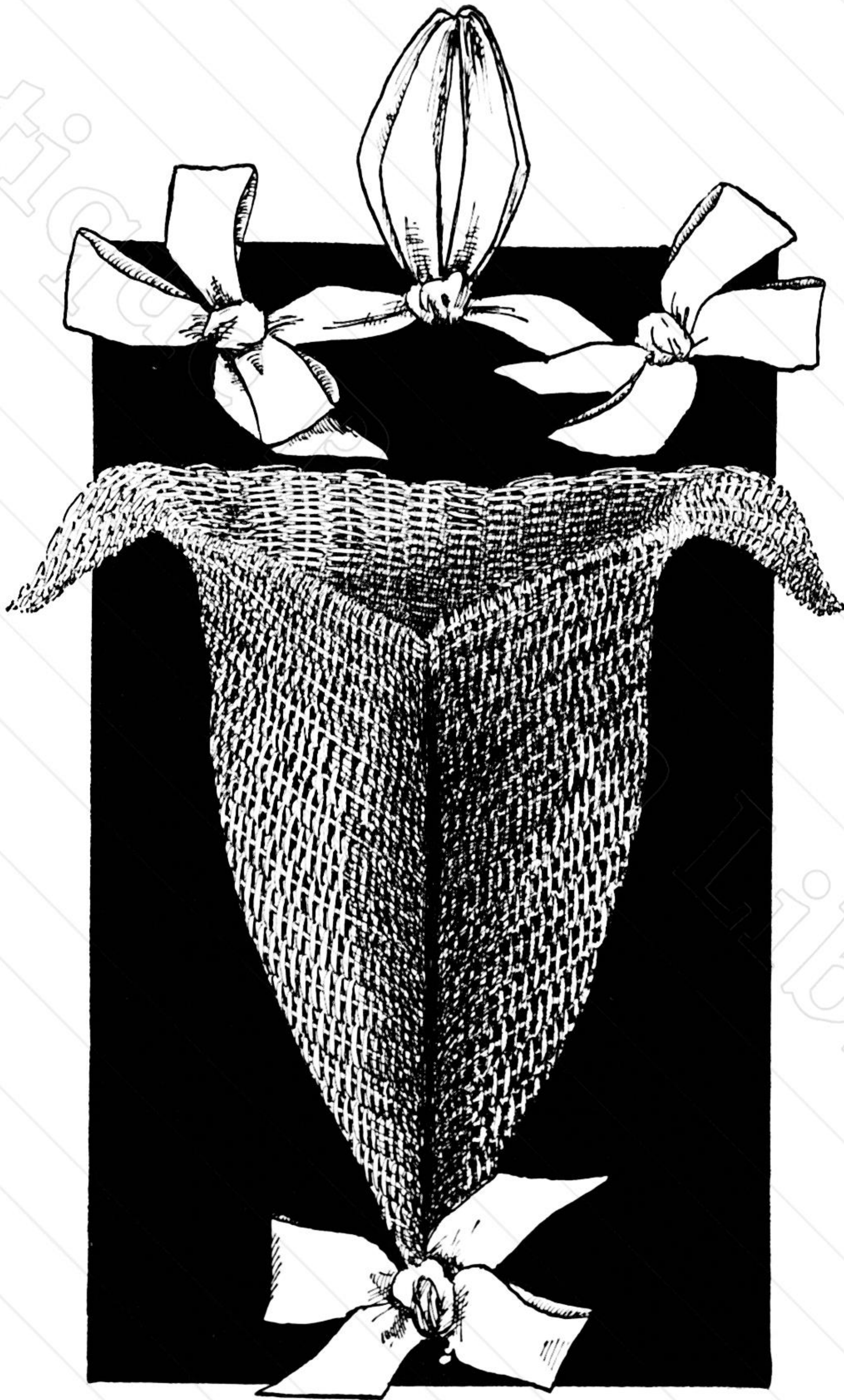

FIG. 143.—Double Fern Pocket.

Rule I.—*Soak the cane in clean cold water for two or three hours before using.*

If the cane be soaked thoroughly, it will become soft and pliable and as easy to manage and weave into place as a length of string or thread.

Beginners *must* use soaked cane until they are dexterous in the work, if not, the dry cane will be stiff, brittle, and unmanageable in their untrained fingers.

One objection to soaking the cane is that it becomes discoloured and frayed, thus losing the smooth, white, glossy appearance which weaving with dry cane gives to an article. However, it is best to learn with soaked cane and use dry for finished and excellent work.

Rule II.—*The foundation strands must always consist of an uneven number of strands.*

All foundations are made of a number of pairs, with an odd strand inserted into the centre, or by leaving an end of the weaving thread and treating it as an odd strand. The odd strand must be considered equal to a set or pair for the first few rounds of weaving. The odd strand is needed so that the weaving thread alternates properly.

Rule III.—*Weave with the right hand, using the first finger and thumb, and keep the hand close up to the weaving.*

Children are liable to weave away from the work, holding the strand some 2 or 3 inches from the article. The work will be loose and uneven if done in this way, so the teacher should see from the first that the weaving strand is held close to the work.

Rule IV.—*Use the left hand to turn the work, and pull the foundation strands back in position, i.e. straight with the centre.*

As the child weaves round from right to left of a *flat* article, the foundation strands will be pulled sideways and remain so, unless they are pulled back into position by the

left hand. In reality the right and left hands work together, the first pulling forward the foundation strands, and the left pulling them back again.

Rule V.—*Weave over one strand, and under the next, keeping the spaces between each strand of equal width.*

This work will not admit of uneven patterns being introduced. The weaving may be varied only by weaving two or three rounds alike and then alternating for the same number of rows (see Fig. 164).

Rule VI.—*Always begin to divide the foundation strands after passing the single strand, if not altered at this point the weaving will not alternate properly.*

Rule VII.—*To begin a new weaving strand, pass the end down by the side of the last foundation ray, or, better plan, weave it under and over the last three strands side by side with the old end. If the cane be coarse, point the ends of old and new strands to lie together.*

Rule VIII.—*When the weaving thread is worked up and a new one is required, leave the old end loose, or temporarily push it down into the weaving, and begin the new one as described above.*

Note.—Pushing the new and old ends into the weaving gives the work an untidy appearance. It is useful for children to begin and end so, but when the article is finished, these ends should be pulled up and cut off close to the weaving on wrong side.

Remarks.—The beginning or foundation is best done by the teacher until the children have acquired dexterity in handling the cane. Children are very soon able to begin simple articles, and, in fact, an ordinary class will be sure to contain a few apt pupils who will be able to prepare the work of the class and teach others how to begin.

All articles when finished are much improved by a coat

of clear copal varnish. The article to be varnished should first be sized, otherwise, if the cane be at all greasy from the children's hands, the varnish will not dry but remain sticky.

Other articles look well dyed. A penny packet of Judson's dye, dissolved in a pail of warm water, will be sufficient for several articles. The articles should be steeped in the water until the cane has absorbed sufficient of the dye for the colour desired, and then varnished.

Another variety of finishing is to use Aspinall's enamel. Here, again, the articles must be thoroughly washed or sized, and the enamel made liquid by the addition of turpentine. It requires putting on thinly and evenly to look well. A small flat mat of 4-inch diameter is the easiest exercise for a first lesson, and, in teaching it, the mat should be kept flat on the desk with the left hand, and turned over to left as the weaving proceeds on the right-hand side.

BEGINNINGS

Children who are learning "to begin" themselves for the first time should not have more than *four* strands to manage, and weave these, first with string and then fine cane. These small centres should be unwound and re-woven again and again until the child learns the knack of doing it.

No. 1

But it is not advisable to worry children at first with "beginning" themselves. If so, they are likely to become disheartened and dislike the work, whereas, they are delighted as they see the work grow under their hands. Therefore, let the work be started for infants and the "beginning on" left till they are proficient in cane-weav-

ing. The illustrations show different methods of arranging the foundation strands.

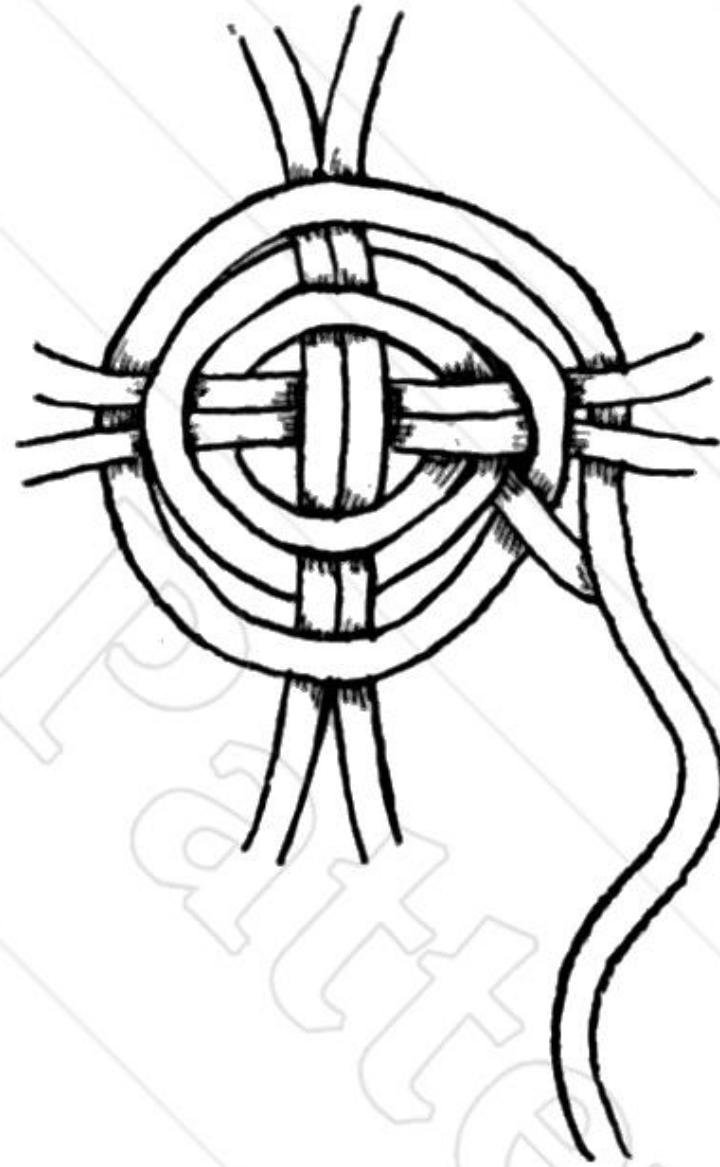

FIG. 144.

No. 2

Cut eight pieces of cane 8 inches long for the foundation. Take four pieces and lay flat across the centre of the other four, making a four-armed cross (see Fig. 145).

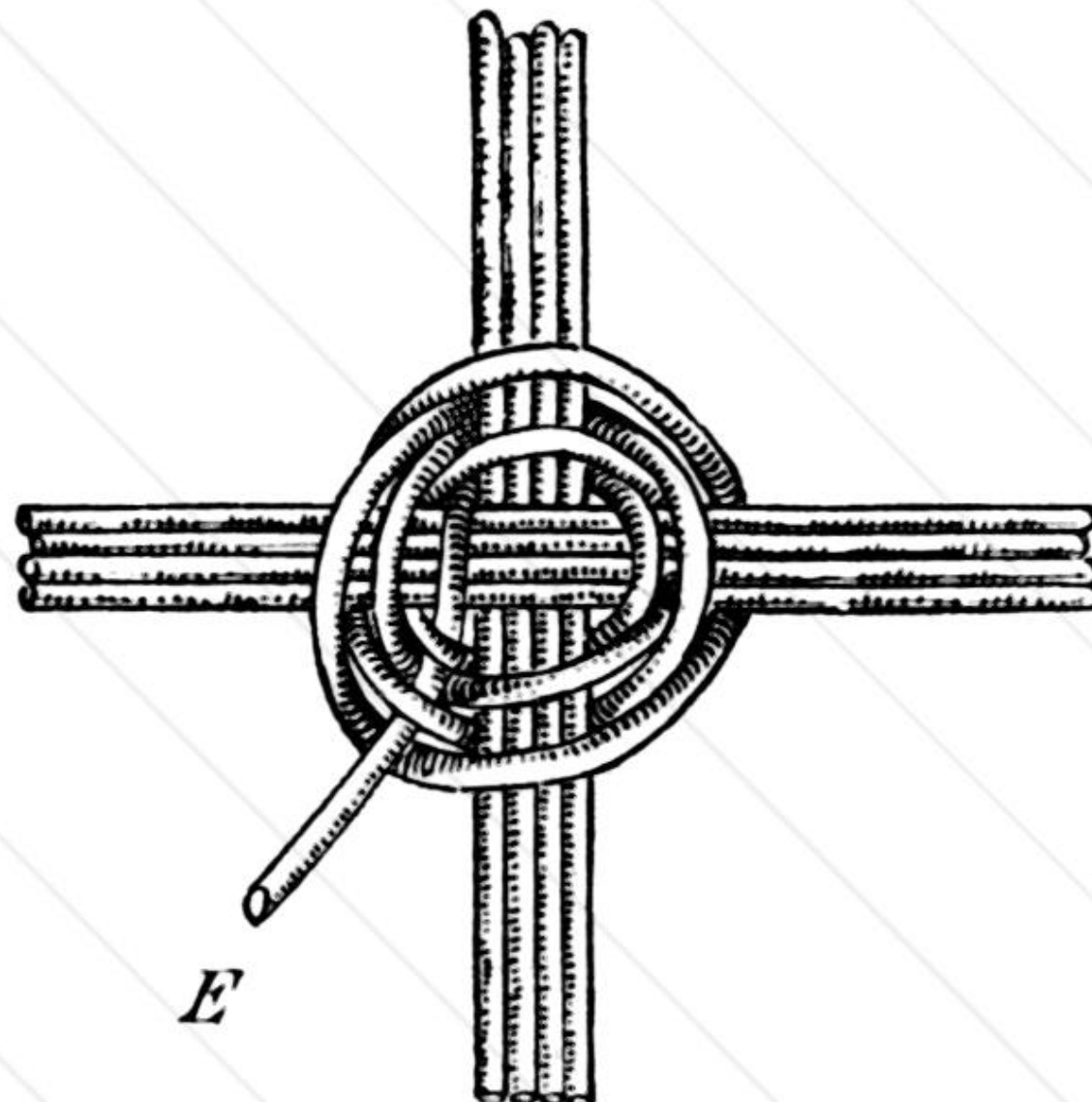

FIG. 145.

Hold the centre firmly in the left hand, and with the weaving thread weave over the left four and under the top four, leaving an end at the beginning as long as the foundation strands. Treat the odd strand as "a set," and the weaving will alternate next round.

No. 3

The same materials, crossed also in the same manner, may be secured by leaving an odd strand and crossing from corner to corner, under the top four, and back over

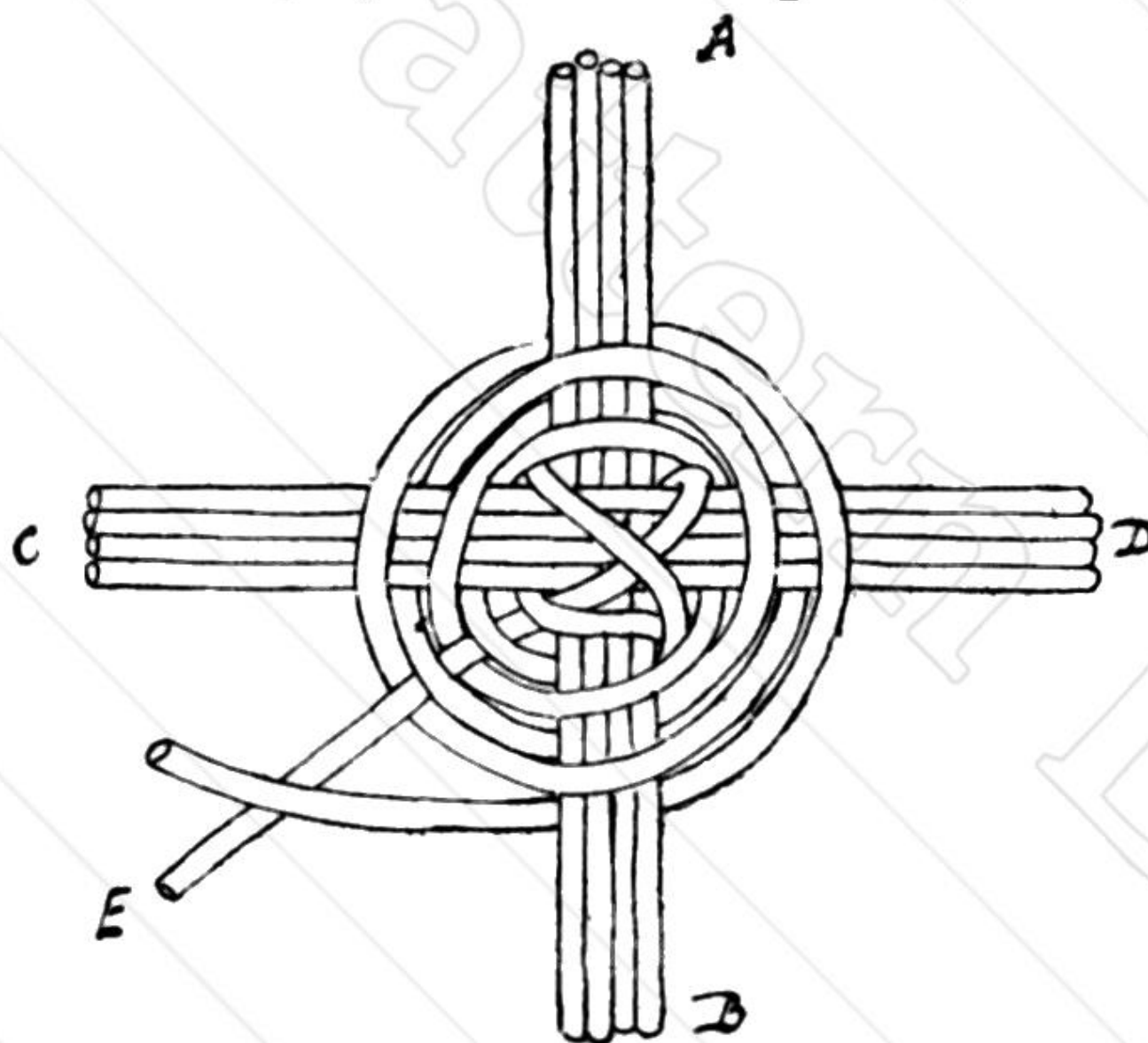

FIG. 146.

the front, from corner to corner. This done, weave round over four and under four, as in preceding exercise.

No. 4

Take eight pieces of cane as before, and arrange in four pairs, crossing in the centre. Hold the centre firmly and proceed to thread with the threader. Place one end of it across the under side to form the odd ray, hold it in position, and then weave round over two and under two, treating

BASKET WEAVING

181

the odd ray as a pair. Draw the first round tightly to make the centre close and firm.

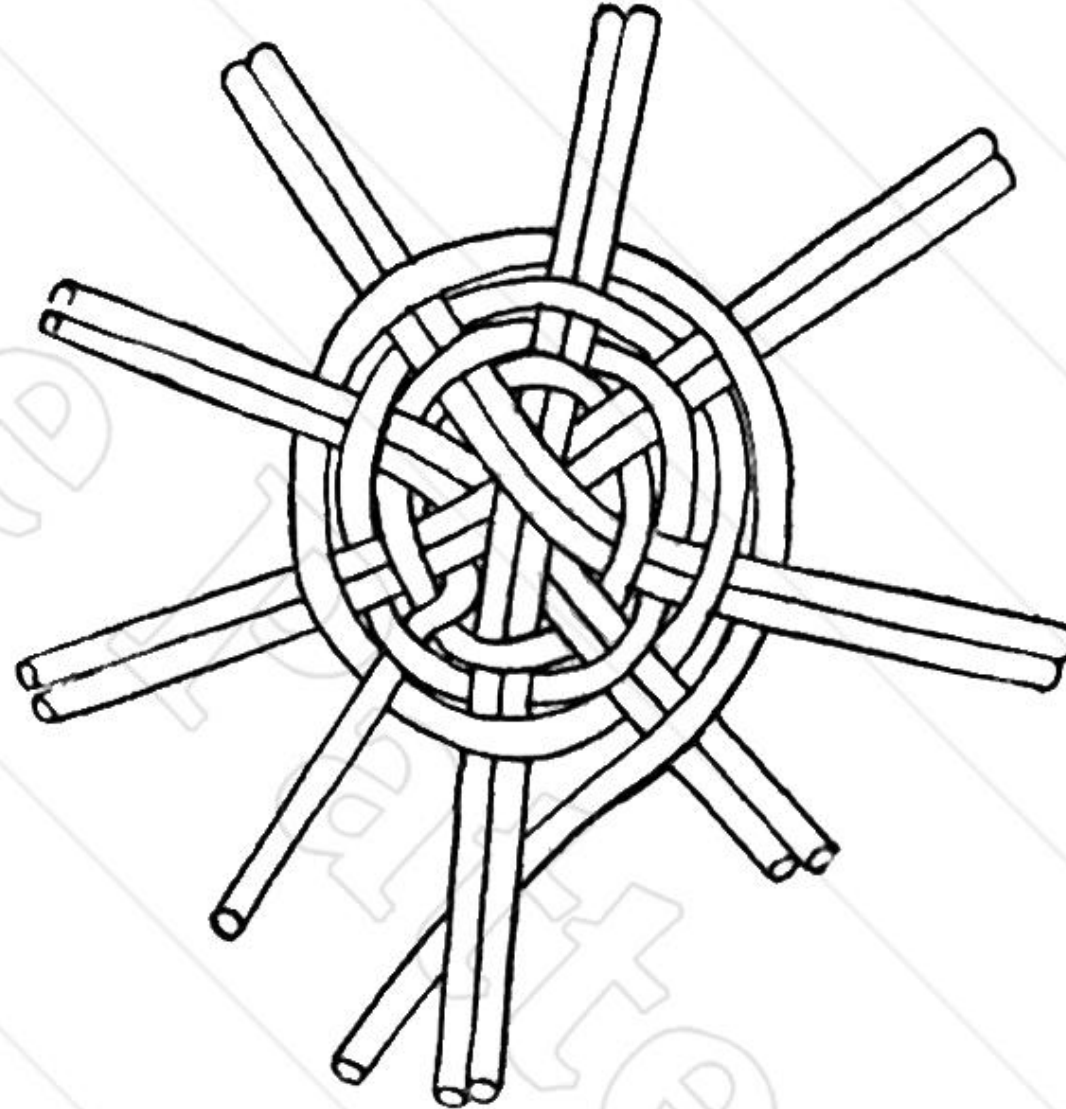

FIG. 147.

No. 5

Take eight pieces of cane as before and arrange in pairs,

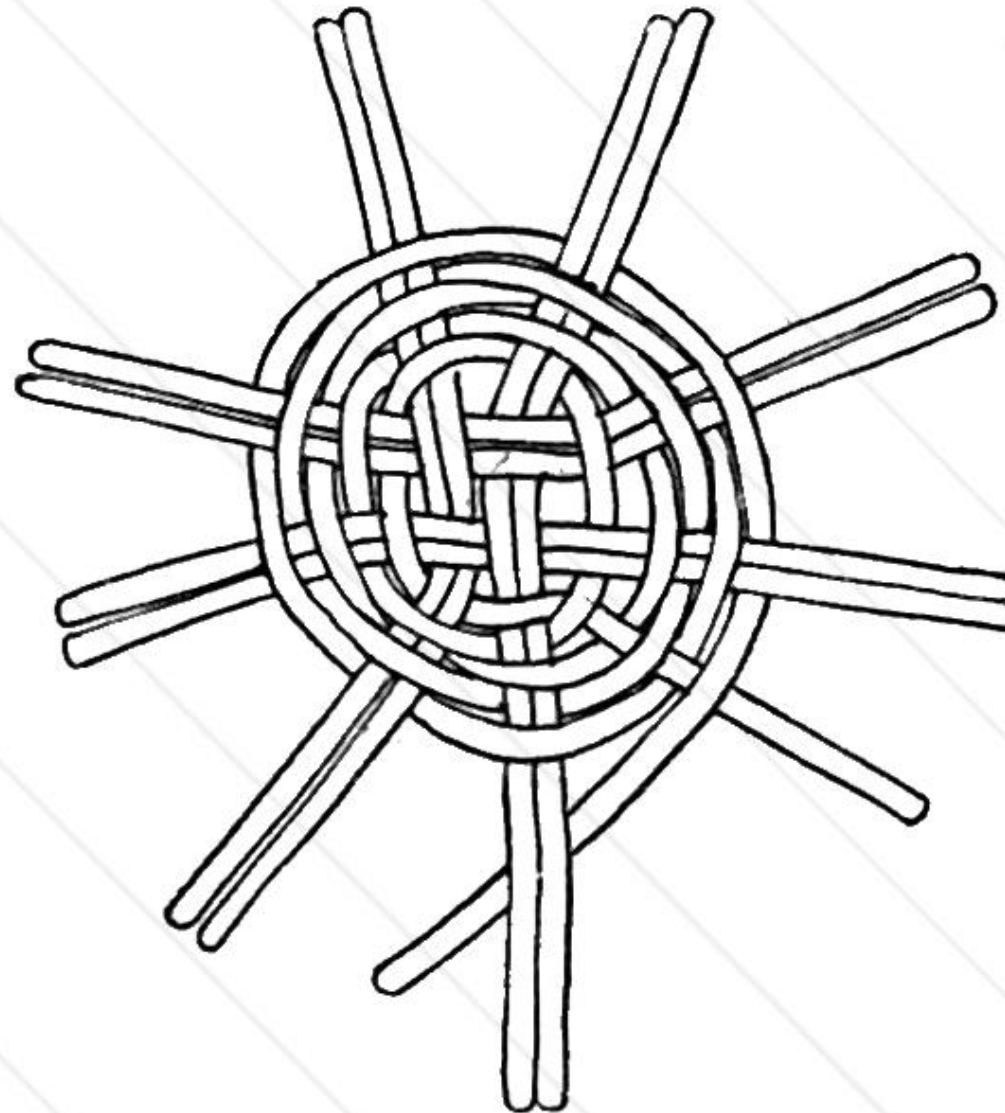

FIG. 148.

placing two pairs vertically and interweaving the other two

pairs horizontally through the centre. Proceed to weave with the weaving strand the same as in No. 1.

Note.—Either of the beginnings may be used for all articles. Larger articles need more strands, these must be divided in similar proportion.

If the foundations are coarse and difficult to secure, the centre cane should be first spliced and then wound over by a strip of bass, the kind of grass used by florists for tying up plants. This arrangement is neat and strong and the weaving afterwards is easy to manage. If the bass is procurable, it is advisable to prepare the work ready for the children in this way.

For the first few lessons, it is a good plan to use common fine twine for weaving instead of cane, until the children have acquired the necessary dexterity in round weaving.

BORDERS

When the weaving of an article is complete the foundation strands have to be fastened off. Upon the border much of the style and finish of a basket depends. The spokes should be sufficiently long enough to reach to the

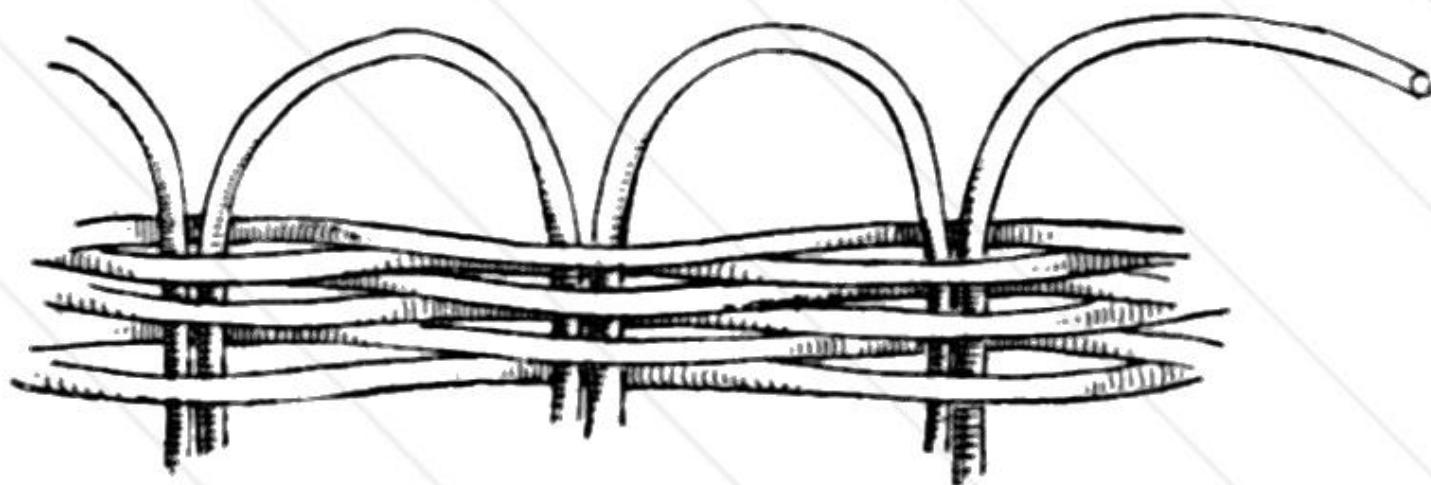

FIG. 149.

centre of a flat article, or to the bottom of the sides of an upright one. This insertion of the spokes really forms a double strand to the foundation, and the article woven is firmer and not likely to lose its shape or become unwoven.

To finish a border, first cut all the spokes equal in length

and gently bend in a semicircular shape. The spokes should be damp, but not too much so, as the cane needs to be stiff to push it down into the weaving. The use of a steel skewer or knitting needle is advantageous for this part of the work. It is so direct in its course that the cane easily follows at the side. The spokes form a series of loops round the article; these may be simple and single, or crossed and interlaced, as in the following figures. Others may be finished by twisting and plaiting the spokes. Of course these are more difficult to do and will require extra supervision of the teacher.

Border 1.—Single strand and single loop. Each end is passed down at the side of next foundation strand.

Border 2.—Double strands and double loops. Each pair of ends is passed down by the side of the next pair of foundation strands.

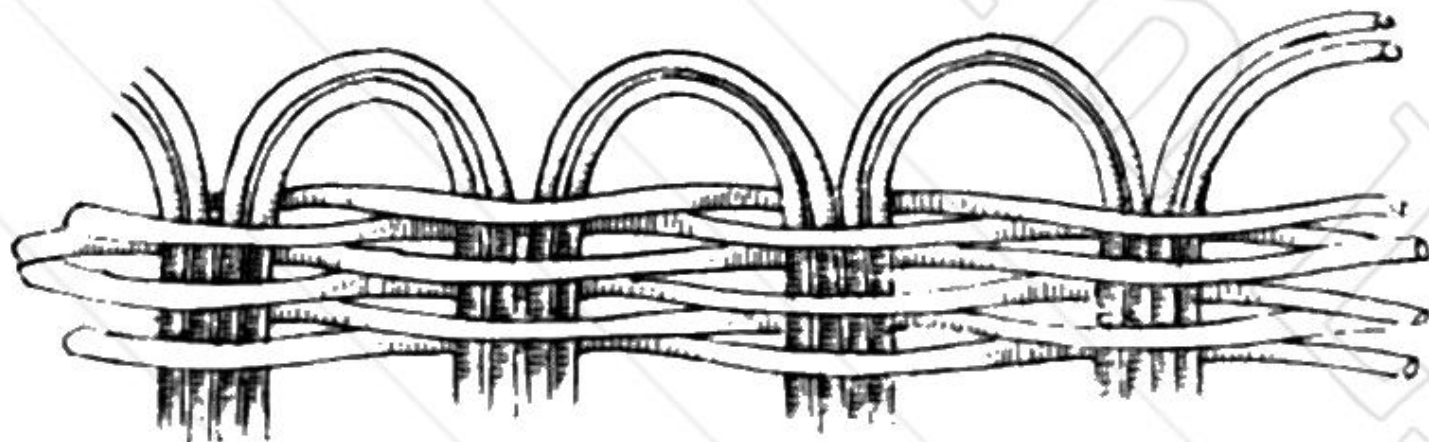

FIG. 150.

Border 3.—Single strands and single loops. Each end passes *behind* the next foundation strand, and is pushed down by the side of the second strand from it.

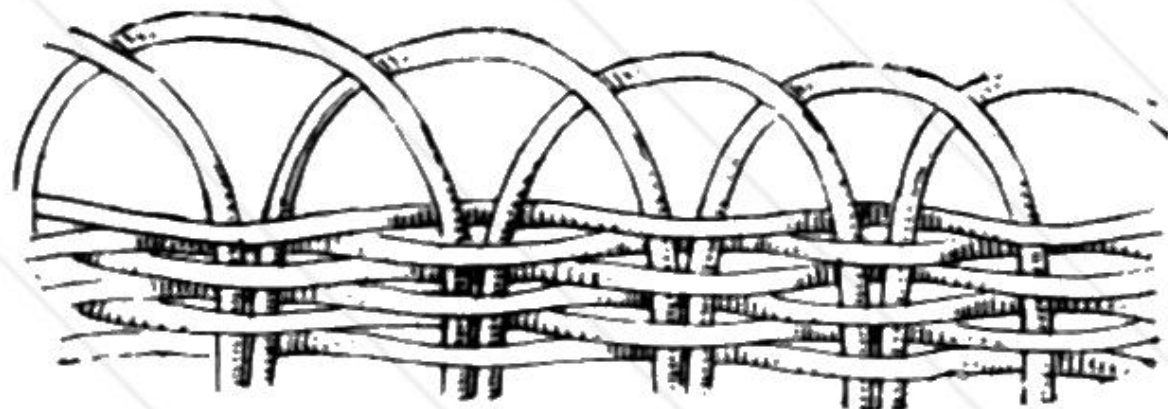

FIG. 151.

Border 4.—Double strands and double loops. Each pair

of ends pass *in front* of the next pair, and are pushed down at the side of the second.

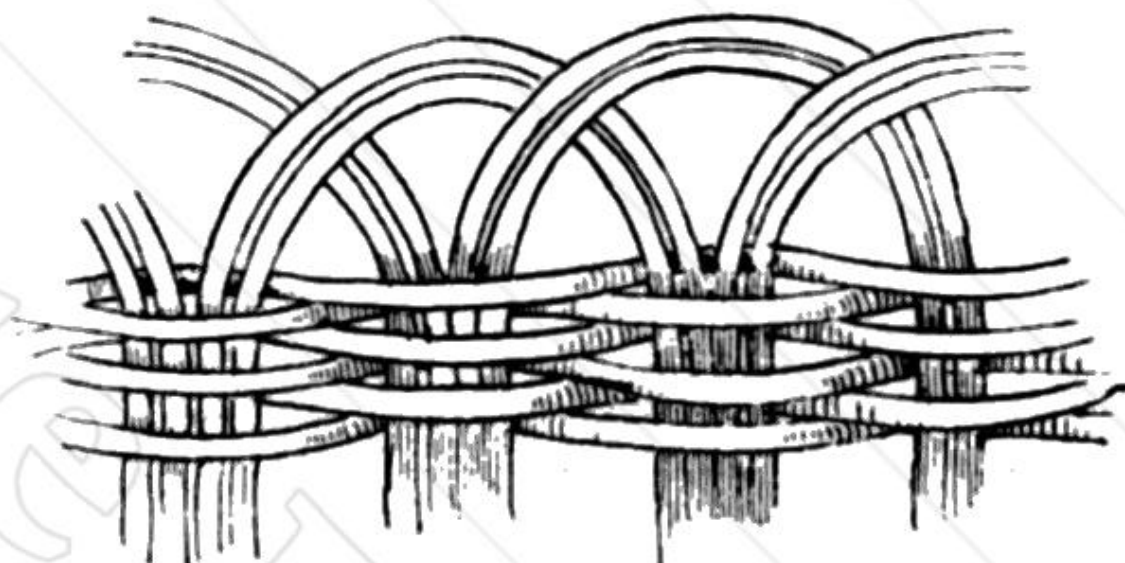

FIG. 152.

Border 5.—Double strands and double loops. Each pair passes *behind* the *next two pairs*, and is pushed down at the side of the *third pair*.

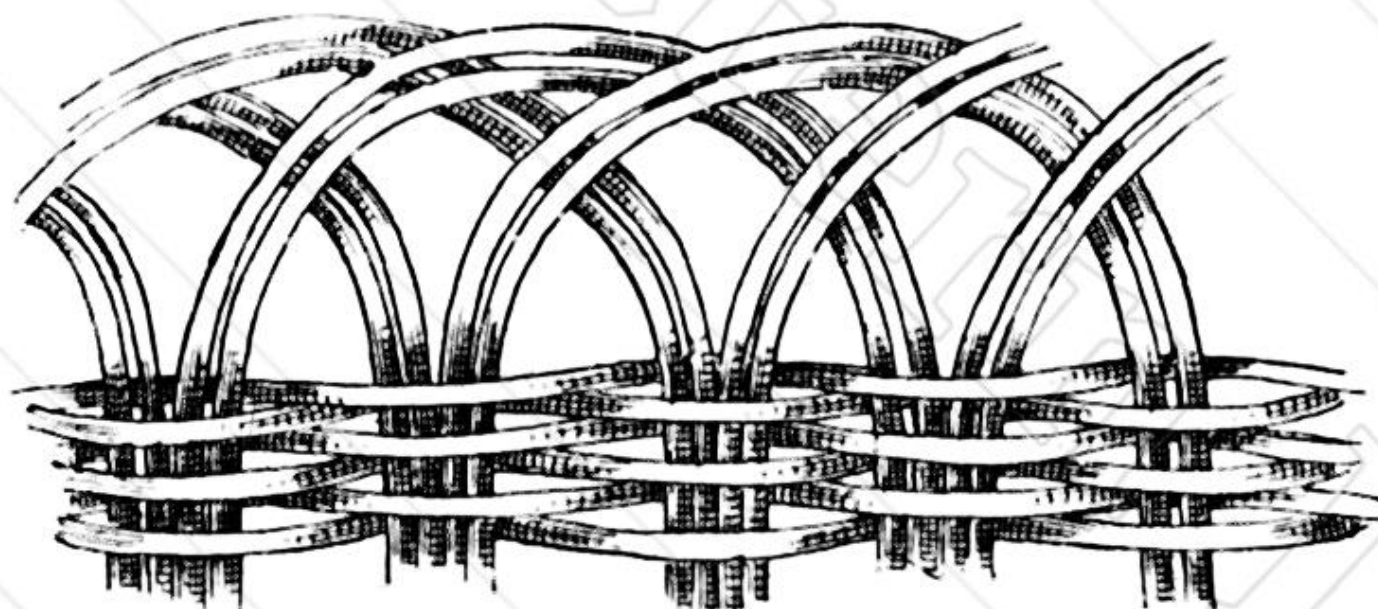

FIG. 153.

Border 6.—The rays may be either single or in pairs. Take one ray, or a pair, as the case may be, and pass by

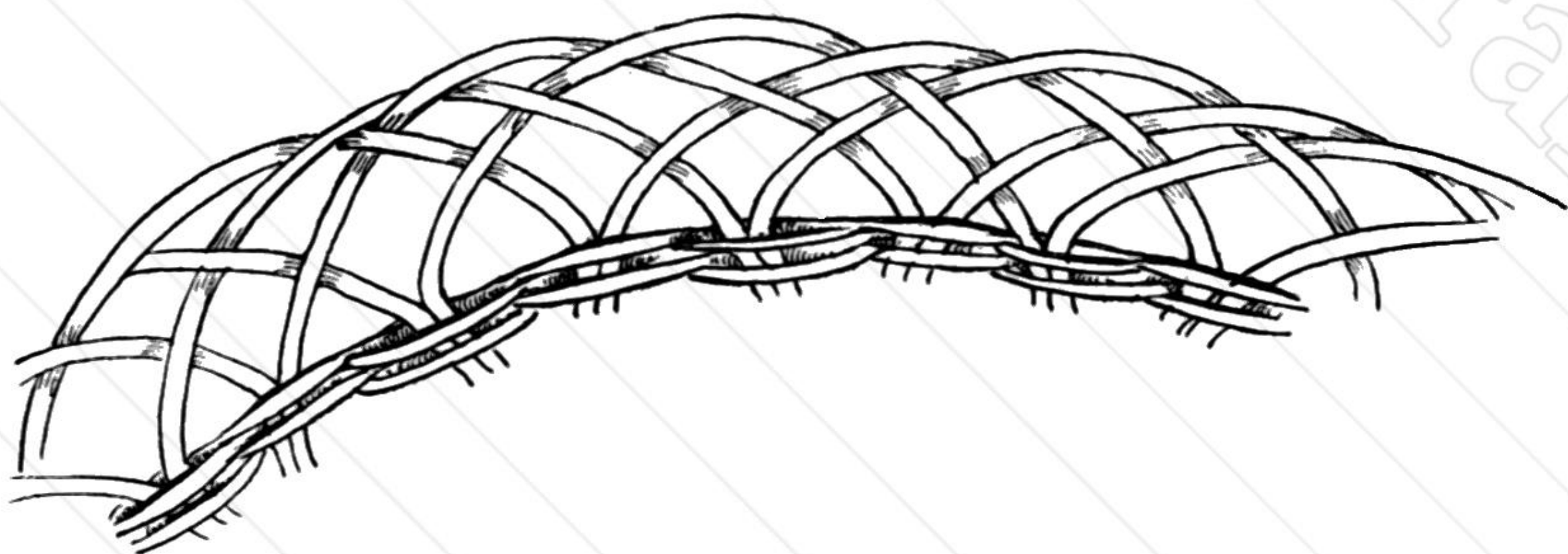

FIG. 154.

BASKET WEAVING

185

the next four or five foundation strands, and insert the end into the fifth or sixth. Press up the loop formed and gently pinch it in the middle. Take the next ray or pair and do the same, passing behind the one next to it, and interlacing the others, as in Fig. 154. Deep borders of open work, such as the above, are improved by interlacing ribbon through the openings.

First Ray.—Take a ray, bend in half-circle, and pass it before the second, third, and fourth rays, and insert it at the side of fifth ray.

Second Ray.—Take second ray, pass it before the next three rays and *under* the loop made by first ray, and then insert into weaving by the side of the *sixth* ray.

Third Ray.—Take third ray, pass under and over and under the loops of first and second and third rays, and then down at the side of seventh ray, or the fourth from itself.

Each ray is treated in the same manner, always going first under, then over, and under the loops, before being pushed down into the weaving. This gives a pretty twisted border (see Fig. 154).

Border 7.—Cut strands of equal length. *Pinch or flatten*

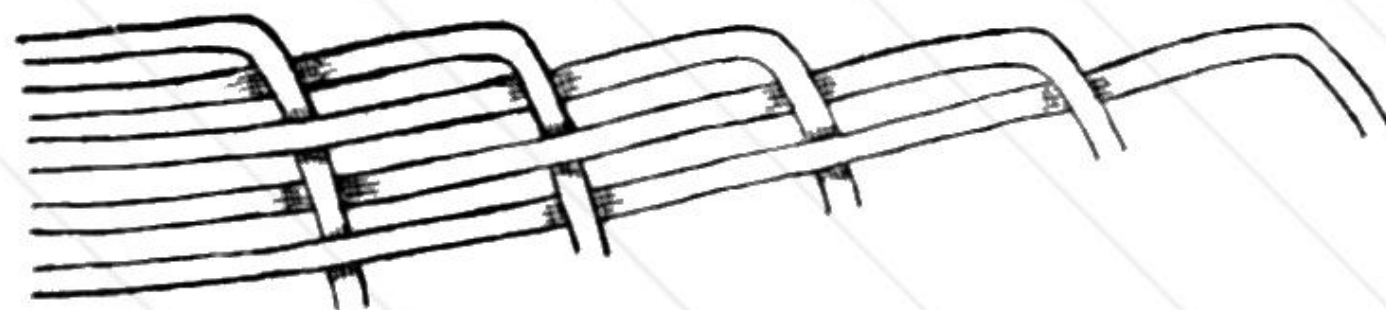

FIG. 155.

each one where it issues from the weaving. Take any strand, weave it over and under the adjoining strands till finished. Take each ray and treat in the same manner.

FLAT CIRCULAR WEAVING

This weaving, as the term implies, consists of circular articles which require to be kept perfectly flat in the weaving, such as round mats, dinner mats, etc. The work should be kept on the desk, and the left hand employed to turn and keep it flat as the weaving proceeds with the right.

SMALL CIRCULAR MAT

Materials.—1. Eight strands of cane (No. 2), 8 inches long, for the foundation.

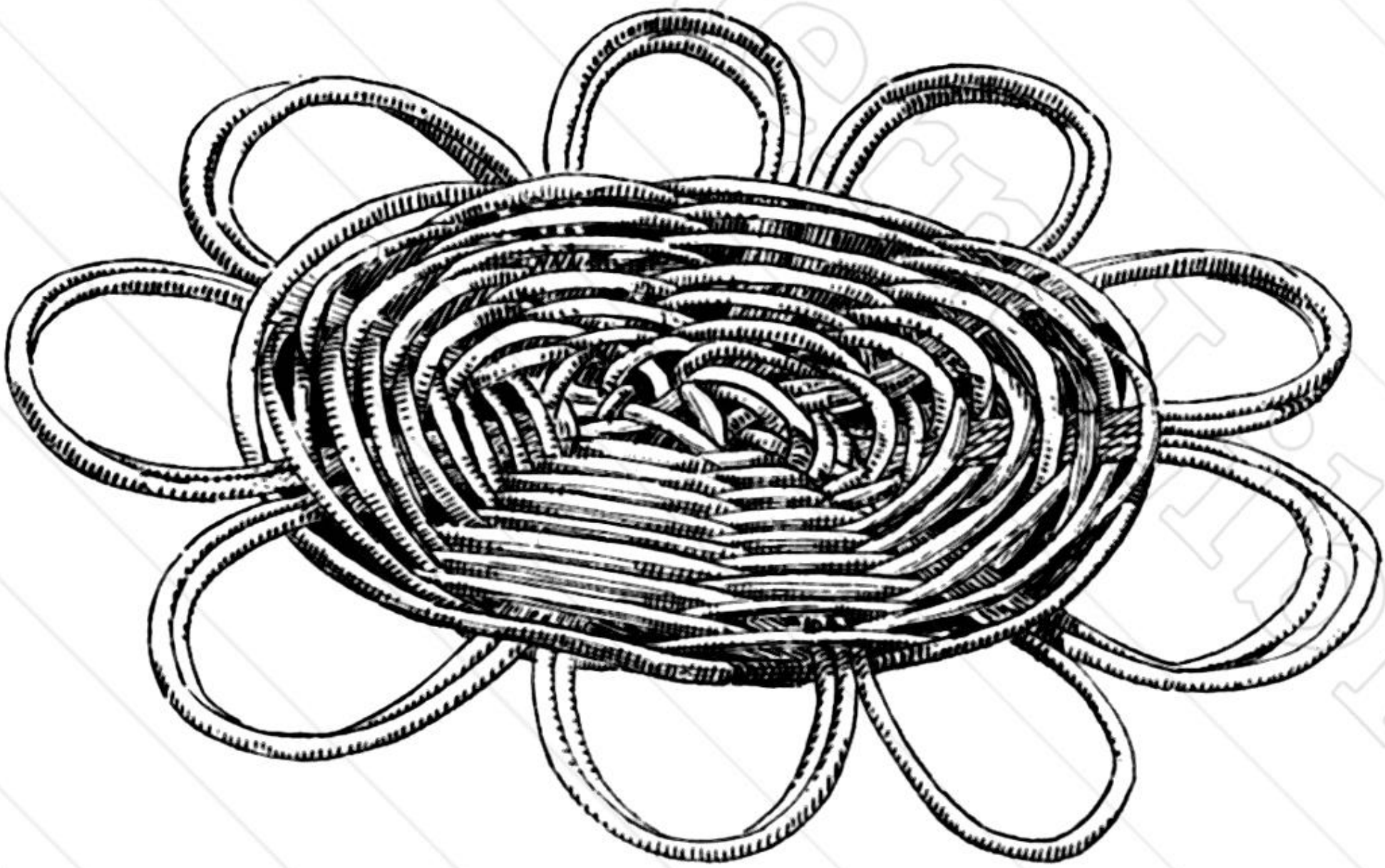

FIG. 156.—Small Circular Mat.

2. A length of weaving cane (No. 1), 3 yards long.

Method.—Show on blackboard how the strands of cane are to be arranged. No. 2 is as simple as any, and will be described in this case. Children to place their canes in position on the desk, the teacher to explain and show some made basket-work, to illustrate how important and neces-

FLAT CIRCULAR WEAVING

187

sary it is for this part to be strong and well made, as upon it the whole of the remaining portion depends. Give the name "Foundation," and refer to foundation of houses, laying foundation-stones, etc. Write word on blackboard.

Teacher to take strands and hold them in correct position before class, *i.e.* as a four-armed cross; children to imitate.

Next take the long "weaving thread," explain why so

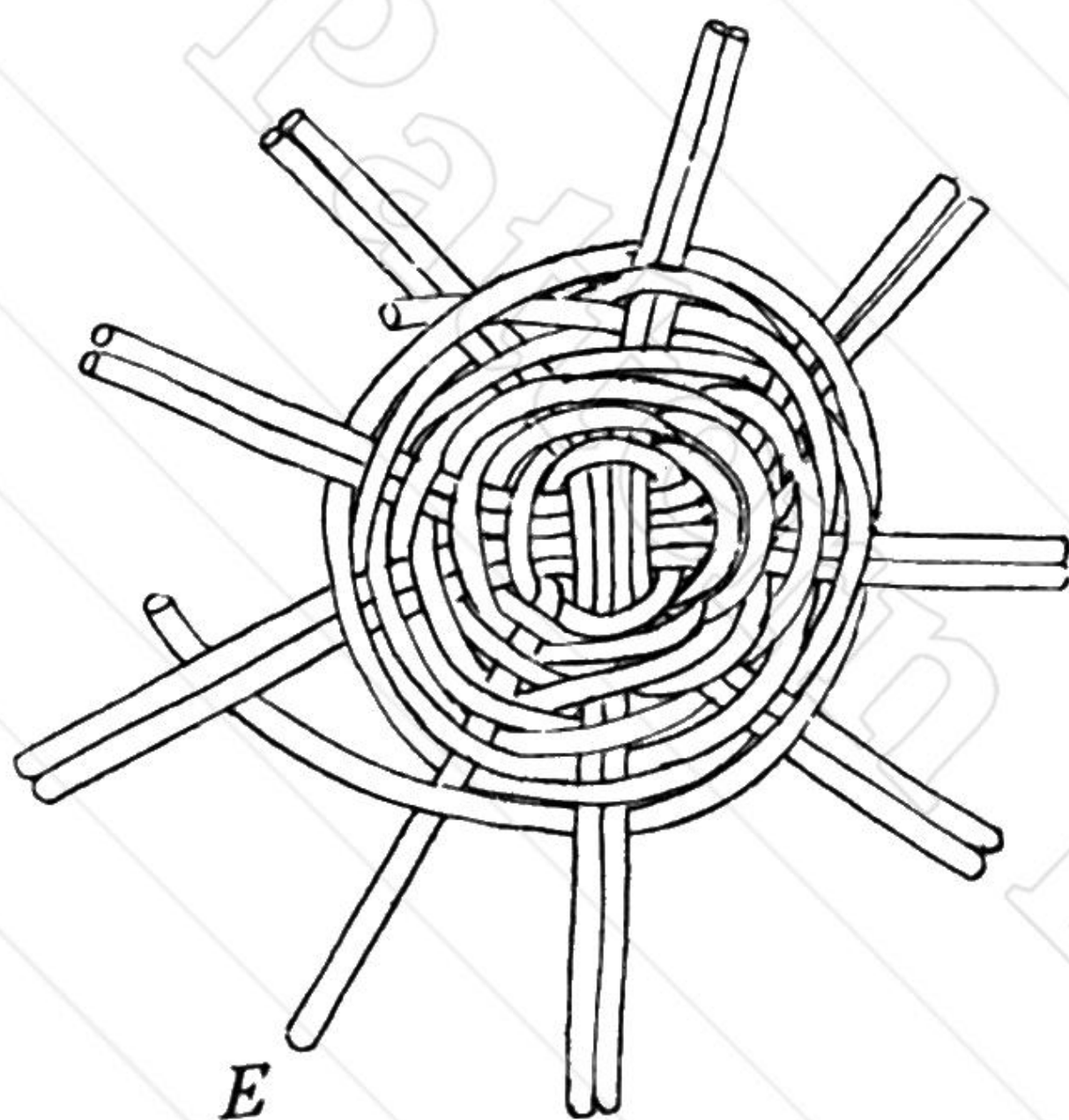

FIG. 157.

called, and compare the foundation to *tight* strips of mat, and the weaving thread to the *loose* strips.

Place the weaving thread E under four and over four, and leave an end about five inches long to make the extra spoke, which is needed to make the weaving alternate properly. If the weaving thread be pulled tight at each step the centre will be compact and firm. The single strand must be treated as a set of *four*, and the children be made to count the "sets."

Whichever way of beginning is adopted, when some

three or four rounds have been woven, the spokes must be separated into "twos," and two must be woven at a time instead of four—two over and two under. This separation must begin immediately after passing the single ray.

When the mat is about four inches in diameter, the weaving thread should be cut off and the end inserted into the mat whilst the border is being done, after which it can be pulled out and cut off short.

Cut all the spokes equal in length, and finish by taking the ends of each two spokes and pushing them into the weaving by the side of next two spokes, as in Figs. 150 and 156.

HOW TO UTILISE THESE MATS

1. *Letter Rack.*—Take a piece of stout cardboard and cover in velveteen or plush.

Sew on four or six mats (one below the other) to the covered foundation, and secure firmly with a few stitches of strong thread. Cover the stitches with a bow of ribbon, or arrange the next mat to overlap and hide the fastening. Only the border portion should be fastened. Tie each mat at the side, and to the foundation, with narrow ribbon, and fasten bows and loop at the top to suspend it. Cover the back neatly with a piece of sateen (see Fig. 99 in "String Weaving").

2. *Pin-cushion.*—Make small mat according to directions. Cut a circle of cardboard 2 inches in diameter, upon it place a ball of frayings or wadding, and cover over with a circular piece of velvet or plush. Gather the edge of velvet with continuous thread, and draw it tightly round the circle of cardboard, as if covering an ordinary mould button. This forms the cushion, which is sewn on to the centre of mat or glued in position. A twisted ribbon tied round

FLAT CIRCULAR WEAVING

189

hides the space between the cushion and mat. Another ribbon is threaded through the border, and bows and loops added to suspend it (see Fig. 98 in "String Weaving").

3. *Candle Shade*.—Make a mat according to directions. Weave two mats exactly alike, and when finished add brass candle clips. Pass the point of clip well into the weaving at the outer portion, *not* the centre, otherwise the flame of the candle will not be hidden.

4. *Card Basket*.—Six or seven of these mats, tied together with bows of ribbon, and tied again to a larger mat for the bottom, will form a pretty and useful card basket.

LARGE ROUND MAT

The new difficulty presented in this mat will be the division of the foundation rays. This separation must *always* take place after passing the single strand, otherwise the weaving will not alternate properly.

Materials required.—1. Fine cane, No. 1, for weaving.

2. Medium cane, No. 3, for foundation.

3. Varnish or enamel.

Method employed.—Cut sixteen lengths of cane 20 inches long. Cross eight upon eight and begin as directed in Beginning 3.

Leave an end for the odd strand and cross the centre diagonally, bringing the weaving thread out again at the same corner. If the second end be twisted round the first and cut off even, the two will form the odd strand (Fig. 159). Begin with a fresh length of cane and weave over four and under four for six rounds, then divide into "twos." Remember the twisted strands are counted each time as a "set" either of "four" or "two."

Pull the weaving thread tight, and keep the work close round the centre at each step. When the weaving thread is used up, begin with a new one, simply passing the end back two or three spokes, side by side with

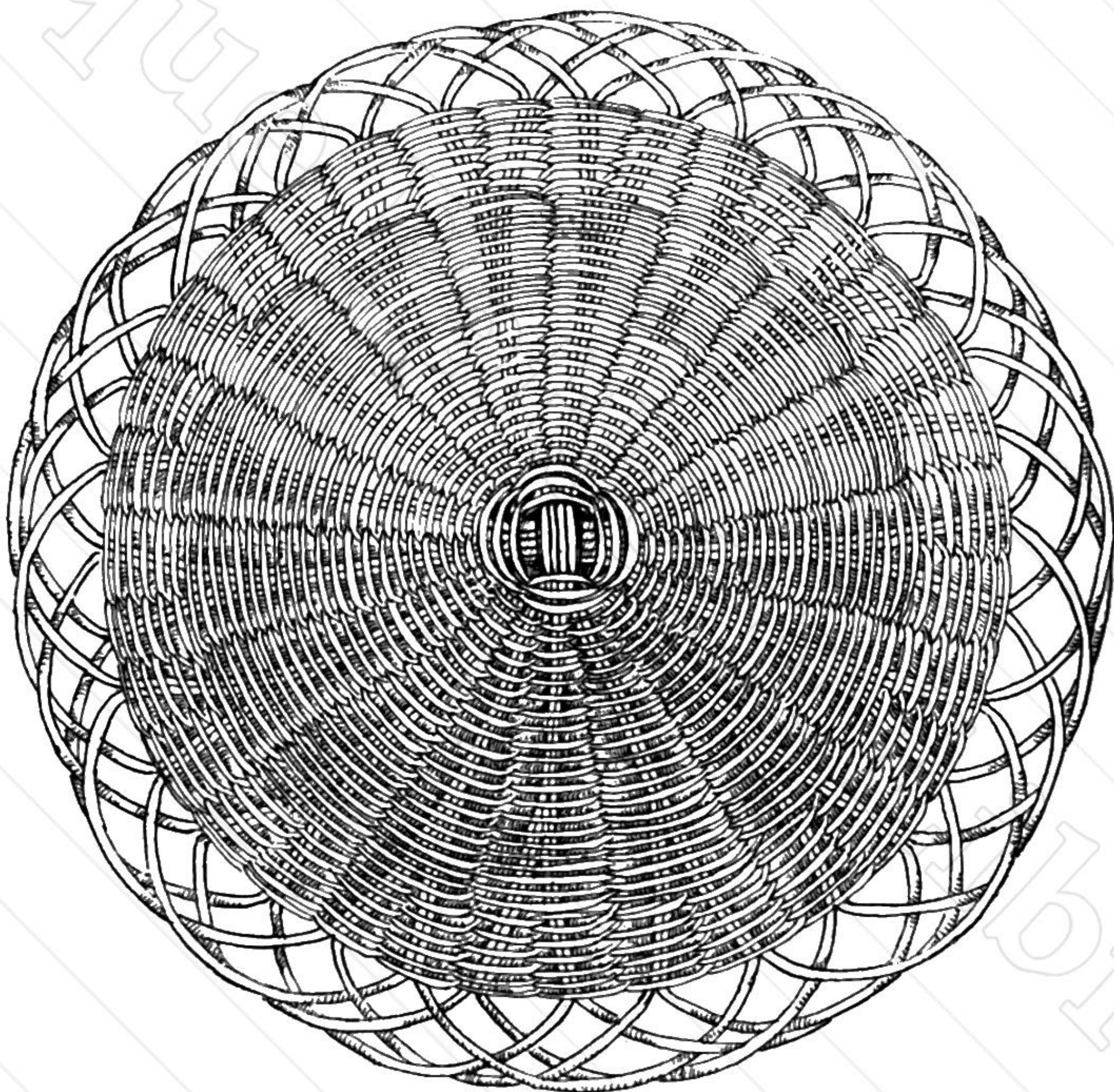

FIG. 158.—Large Round Mat.

the old end. As the weaving proceeds, these ends will be tightened and held in position by future rounds. If the cane is fine no difficulty will accrue from these ends, but if the coarse cane is being used, both the old and new end should be spliced so as to lie together and form the size of the whole cane.

FLAT CIRCULAR WEAVING

191

When the weaving has proceeded to 2 inches from the centre, then divide the "twos" into "ones" directly after passing the single strand, and proceed one over, one under, for six or more rounds. When the circle is about 10 inches in diameter, the mat is finished all but the border. This would look well done according to Fig. 154, behind

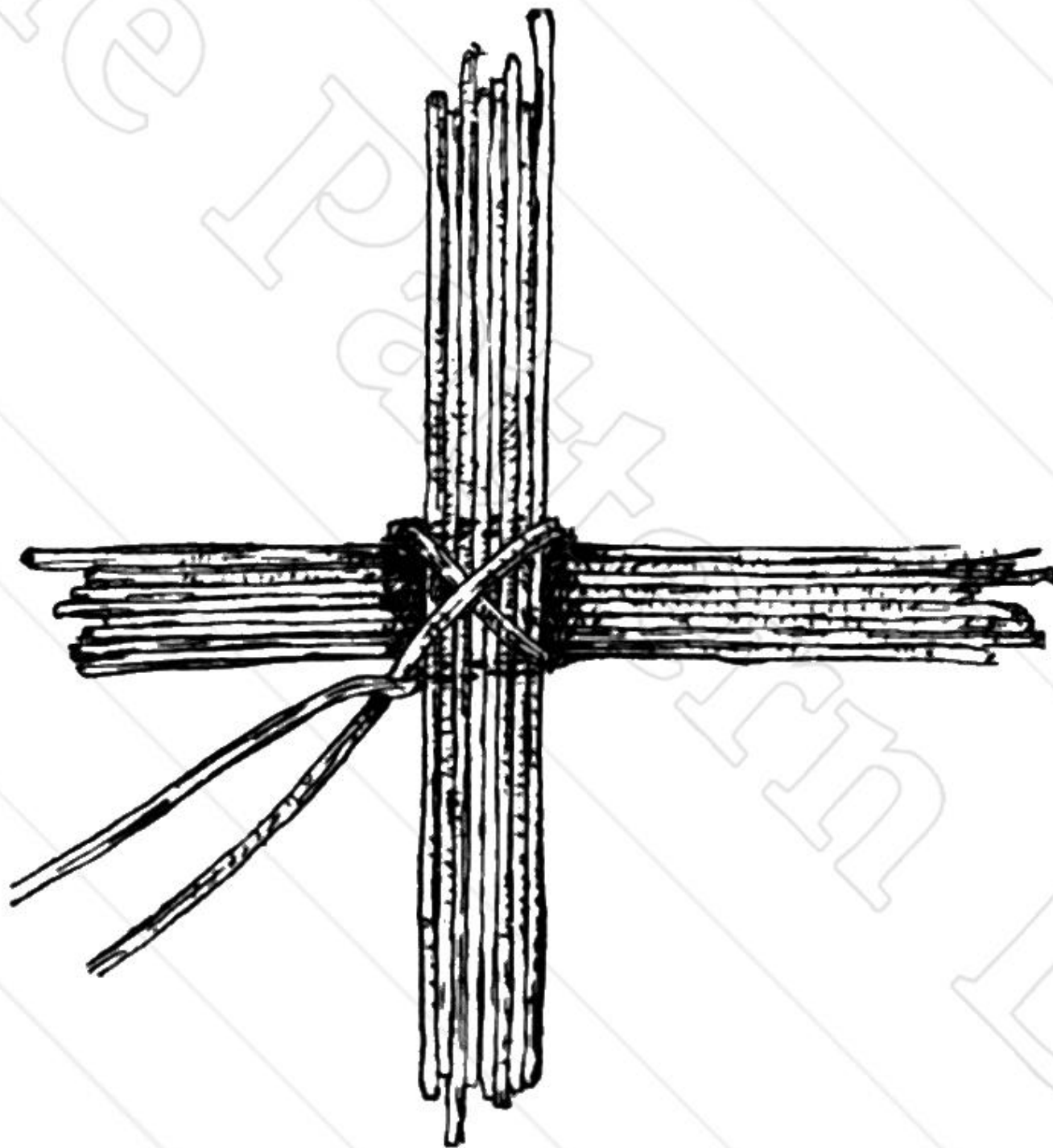

FIG. 159.

one, over second, behind third, and down beside the fourth ray. Finish by using a stained varnish.

Uses.—1. Forms a very good circular table mat.

2. Forms a very good hand-screen by inserting a handle between the weaving, up to the centre, and decorating with cord and tassels, or ribbon and bows. A wooden knitting pin is suitable for handle.

3. Cover one half in gathered silk to form wall pocket and ornament with ball trimming, made in the school, and suspend with bows and loops of ribbons.

OVAL DINNER MAT

One way of beginning these mats is to tie the cross spokes in position with a strip of bass, but a very easy way, and one which the children can manage themselves, is the following:—Give each child a long length of thoroughly wet cane and a slate (10-inch slate for largest dinner mat, 8-inch for medium, and the short side of slate for smallest

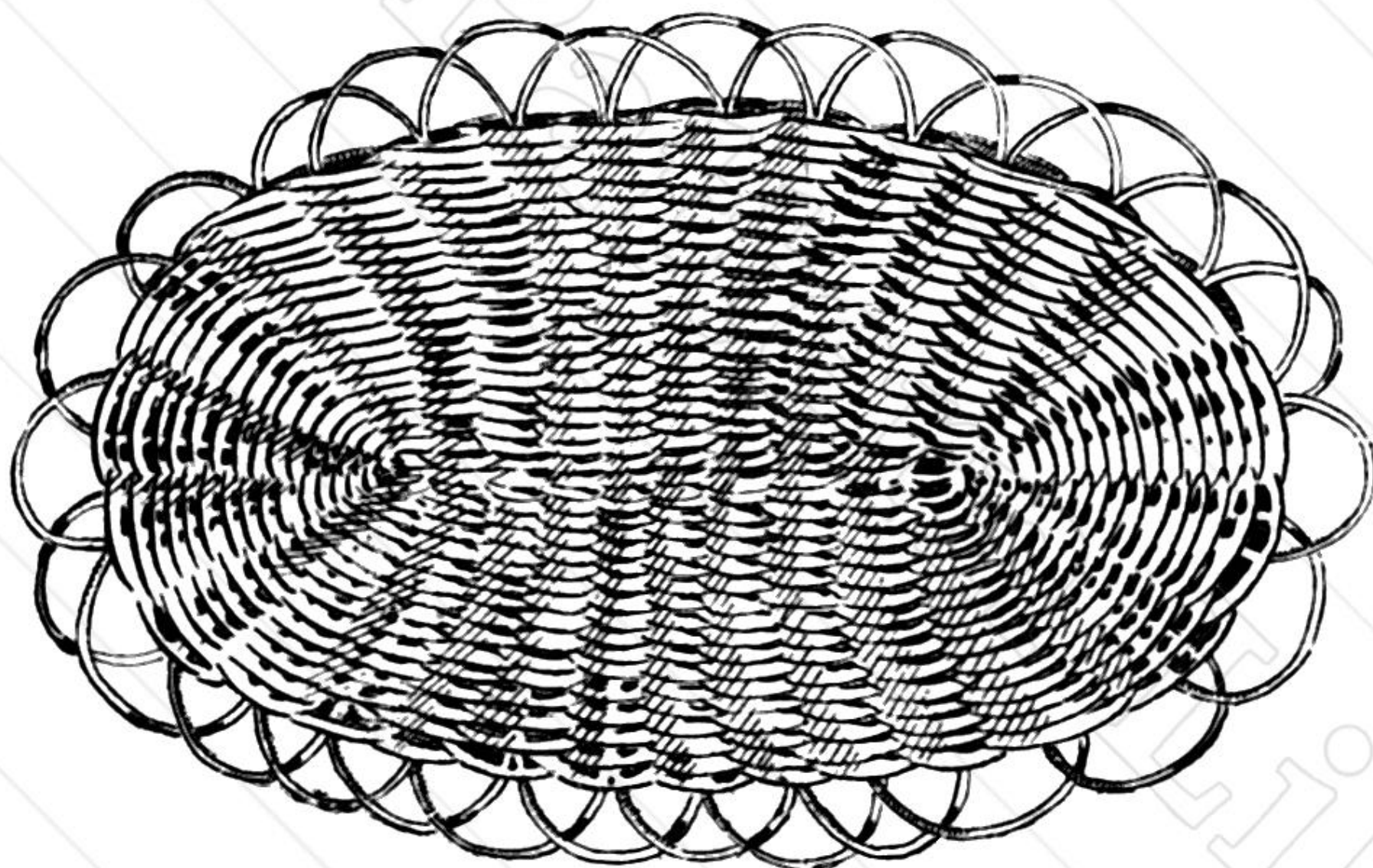

FIG. 160.—Oval Dinner Mat.

dinner mats), hold end of cane under thumb of left hand, and wind the length tightly round until used up. Tie ends together with string and place slate on desk, with the ends of cane underneath. Cut five lengths of cane 10 inches long and weave across the strands on slate. When the five lengths are inserted push the weaving close together till the strands on slate touch, and this will throw the cross strands about one inch apart, as in Fig. 162. When a tight narrow centre has been formed, turn over slate and cut all the strands across the middle. Remove slate, and flatten

FLAT CIRCULAR WEAVING

193

spokes into position. Begin weaving, leaving an end to form the odd strand. Pull the first two or three rounds *very tightly* to secure a close centre. After about six rounds the corners will need more strands; these must be inserted *in pairs*, and will be held firmly by the rows already woven.

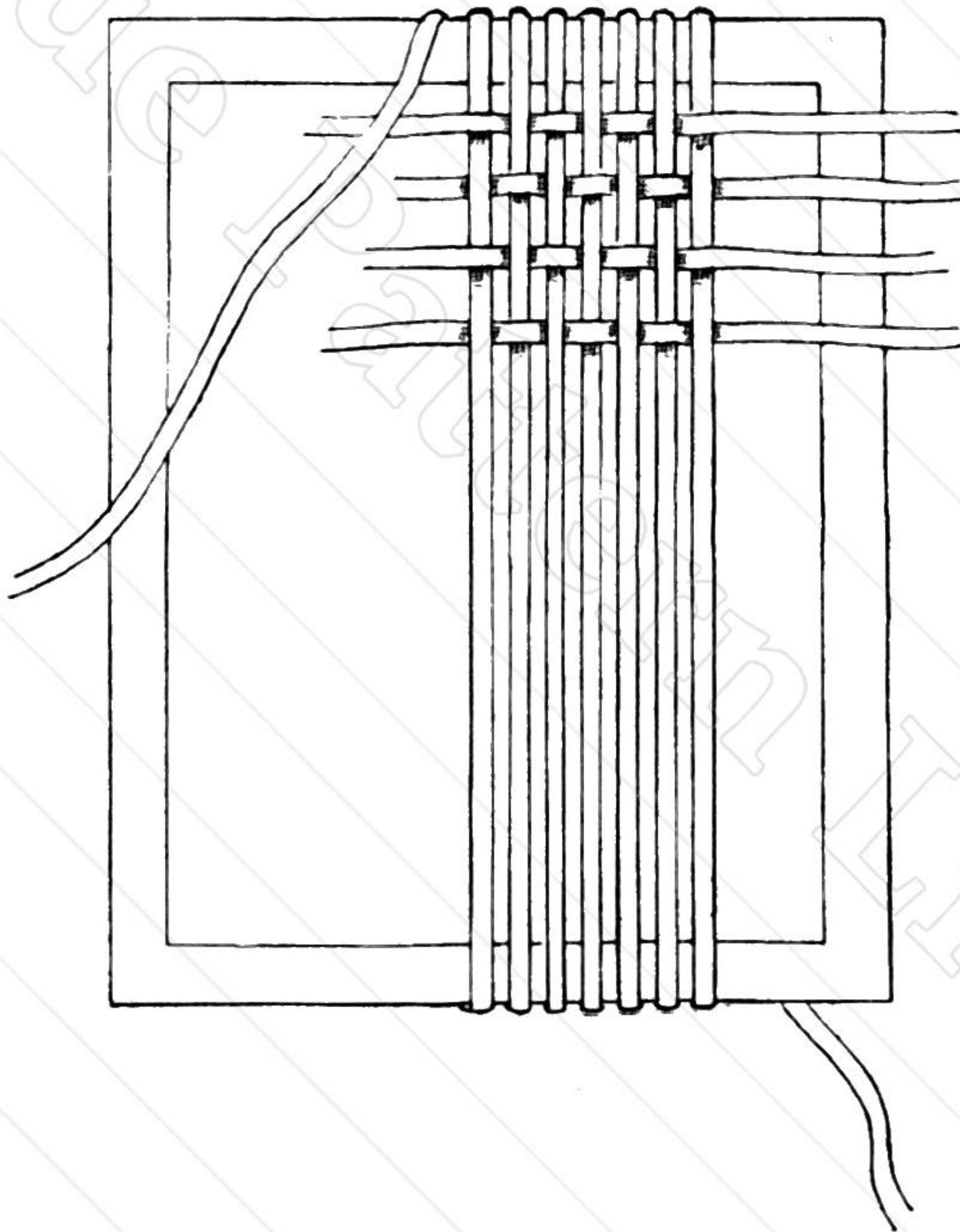

FIG. 161.

To give the roundness to the sides, which cannot be obtained if the weaving proceeds evenly round the mat, short lengths of cane are woven *down the sides*, *two* separately from time to time, and these are kept in place by the long weaving thread which passes round as usual, enclosing the short lengths and keeping them in position.

O

This process needs to be repeated twice or three times in making a large mat to get the requisite curve for the sides.

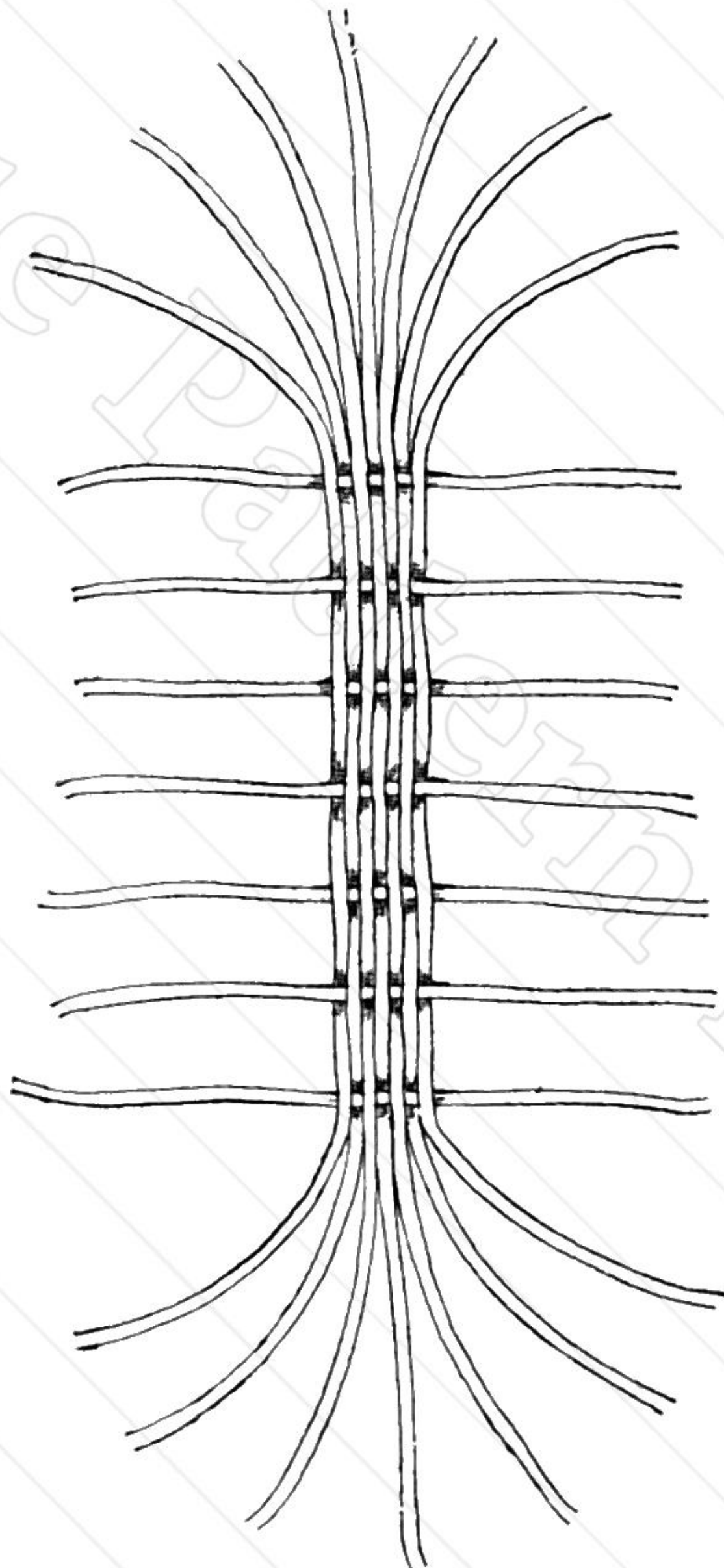

FIG. 162.

These mats are beautifully flat, and when varnished or enamelled scarlet, are fit for any dinner table. Six mats go to a set—two large, two medium, and two small.

The above directions are given from actual experiment and experience.

The same method, employed for oval mat, will be followed for producing the bottom of all oval articles.

If young children are engaged in this work they are able to get the centres prepared, but the first two or three rounds of weaving should be done to get the spokes in position, after which the children can proceed unaided. Stout cane foundations will need no corner spokes inserted, as the cane can be bent in position to do without, as in Fig. 162.

SHELL FIRE-SCREEN

Materials required.—1. No. 4 cane for foundation.
2. No. 1 cane for weaving.

Method.—This screen consists of a wooden easel and three large woven mats pressed in shape to represent three large shells. Each circle is slightly smaller as it ascends, but all are made according to the same directions. The easel measures 24 inches high, and is enamelled pale green. These easels may be bought in various sizes at any fancy repository from 4 $\frac{3}{4}$ d. upwards. When complete the shells should be filled with artificial flowers and grasses, and the top ornamented with a large bow of ribbon. Smaller stands may be made upon the same principle, and used as photograph stands or letter racks for table use.

Circles.—The large circle measures 16 inches in diameter, the second 14, and the third 12. Twelve rays form the foundation of each circle, and the beginning is rather handsome in appearance. Divide the strands into “threes” and arrange them upon each other as an eight-armed cross. There is no odd strand to be inserted in this beginning, but “three over” “three under” is continued throughout till

a circle of 6 inches has been woven, when the rays are divided into "ones." Three rounds alike, *i.e.* going over

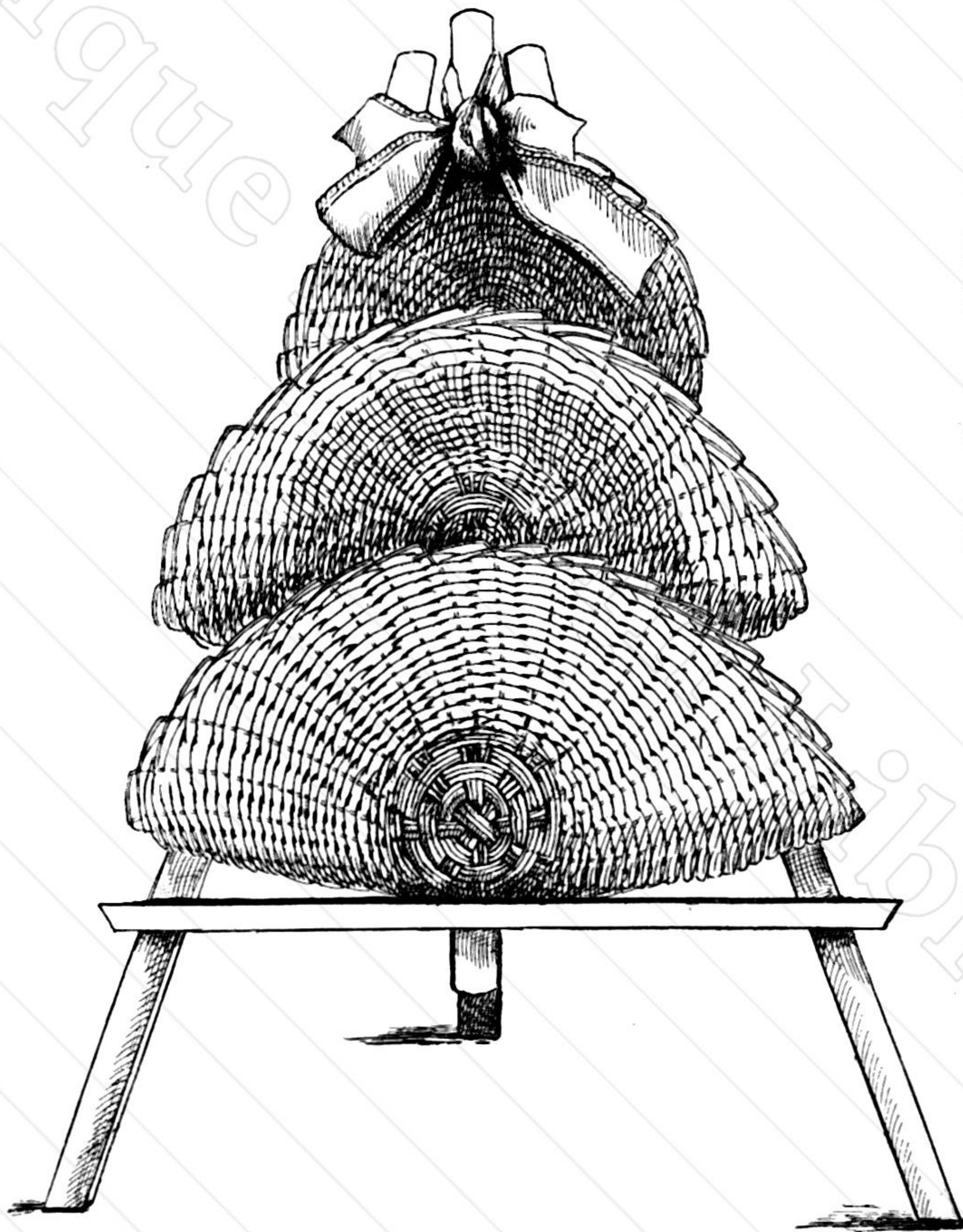

FIG. 163.—Shell Fire-screen.

and under the same, are woven each time and then alternated for another three rounds. When the alternation has

FLAT CIRCULAR WEAVING

197

to take place the weaving thread is passed on the wrong side under two sets of strands. It will be perceived that this is actually necessary so that an alternation can be made, as the strands being even, the weaving must continue the same, unless changed in this way. When a centre of 6 inches in diameter has been finished in this way, divide

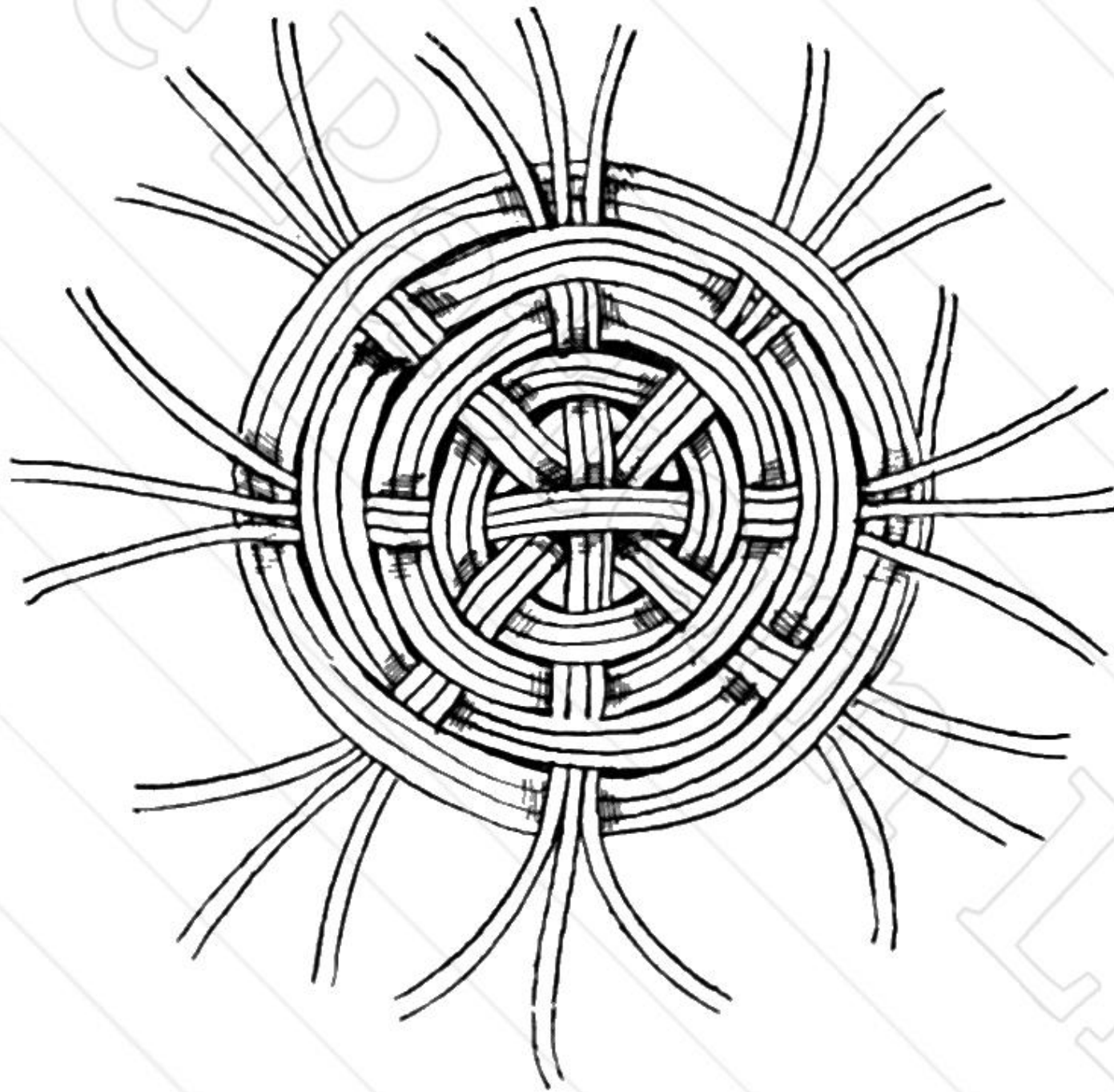

FIG. 164.

the spokes into "ones" and insert an odd strand. Continue plain weaving until mat is of the required size.

Border.—This may be finished according to taste. The one in illustration is worked according to Border 7 (Fig. 155). To make the mats the desired shape, thoroughly soak them in warm water and turn up about one quarter of the weaving. Press firmly into position and secure with string and leave till dry. Then thoroughly varnish inside and out, and fasten with small tacks each shell to the stand. Finish off as described above.

Note.—The large Japanese umbrella fire-screens make very good foundations for the same in cane-weaving. Strip off the paper and begin to weave where the ribs join the under portion. The top will be open, and the weaving can be varied by having coloured ribbon, string, or plait introduced at intervals. The umbrella will not close, but makes a good substantial fire ornament.

UPRIGHT CIRCULAR WEAVING

The children having become proficient in flat circular weaving are now introduced to a new difficulty, viz. that of upright circular weaving. From actual experience it will be found more profitable in the end, if the children treat with this kind of weaving, independently of the flat.

Upright weaving is introduced before basket-making, because it presents a new difficulty to the child and yet is not so troublesome to do as an entire basket of wicker. Any shape is possible to get where the bottom is provided. The weaving is more regular, because the strands are fixed at equal distances, and there is no skill required to keep them in place.

WASTE-PAPER BASKET

The large packets of brown cardboard circles and rims sold for stick and paper weaving are very useful for this work. The circles are already punched to receive sticks. These baskets if made with sticks are not worth the trouble bestowed on them, because immediately the basket is used the bottom falls out and the basket becomes useless. By using cane instead of sticks this fault is avoided. The largest circle which measures about *eight inches* in diameter

UPRIGHT CIRCULAR WEAVING

199

is very useful for making a waste-paper basket. The circles are nicely stamped with a central pattern, and the edges well finished, thus giving a much nicer appearance than if the circle were cut by hand. The cardboard rim also supplied in the packets is of service to hold the canes in position temporarily until a portion of the basket is done, and the strands are held in place by the weaving. Two ends of one piece of cane are threaded up through two adjoining holes which securely holds the bottom to the weaving. The holes in each circle are even in number, so one hole must be missed or another made to get the number uneven, which is necessary for the weaving to alternate properly. When inserting the odd strand splice the lower end and wedge it up through the adjoining hole for security.

An effective way of weaving is by taking two canes together and weaving as one. It is necessary to keep them untwisted and not to renew two new lengths at the same time. Occasional rows of straw plait introduced also tend to improve the appearance of these baskets. The borders are finished off in any of the ways shown in Figs. 149-155.

SHALLOW BASKET FOR FLOWERS

Cut cardboard circles a little larger than a tinned tongue can, and with a red-hot knitting needle or punch perforate the edge with an uneven number of holes about three-quarters of an inch apart. Cut a number of strands of cane 12 inches long, bend in half (but do not crack the cane), and pass the two ends through two separate holes side by side. Continue round the circle till one hole is left, through this pass a 9-inch length of cane and point the under end

and wedge tightly into the adjoining hole with the next strand of cane. The article is now ready for weaving, and the strands being uneven and at equal distances apart, the weaving will be simple and regular and useful when complete.

Let the weaving be as deep as the tin can used. Fasten off the ends with a fancy border interlaced two or three apart. Wash the tin can thoroughly, and be sure to procure one which has been evenly cut round the top. Enamel it inside and out, also the cardboard bottom of basket. When dry, place the can inside basket, and use for cut flowers.

If the cardboard edge protrudes beyond the weaving, it is easily hidden by a three-plait of cane, or a piece of twisted ribbon.

Circles of any size may be cut, and baskets either shallow or deep can be made in this way.

DEEP BASKET FOR TOBACCO JAR

This basket is made in the same way, and the can used is a golden syrup can with cover. The weaving is done over and under two foundation strands throughout and not again divided. The spokes are pushed close down at the top instead of forming a border, and a small mat woven in same manner is tied on to form the cover. The whole is enamelled, tin and basket, and forms a useful biscuit or tobacco jar.

Square and triangular shapes may also be woven in this manner, but to maintain the outline correctly a Kindergarten stick is needed at the corner holes, as the cane is not sufficiently stiff, to keep a sharp turn. A novel method of combining flat and upright weaving is shown in the wheelbarrow and mail cart.

SMALL WHEELBARROW

- Materials required.**—1. Cardboard for foundation.
2. Cane No. 1 for foundation rays.
3. Cane No. 00 for weaving.

Method of Weaving.—*Base.*—Cut a cardboard base 4 inches long, $3\frac{1}{2}$ inches wide at back, narrowing to $2\frac{1}{4}$ inches at front.

Pierce four corner holes first and then five intermediate

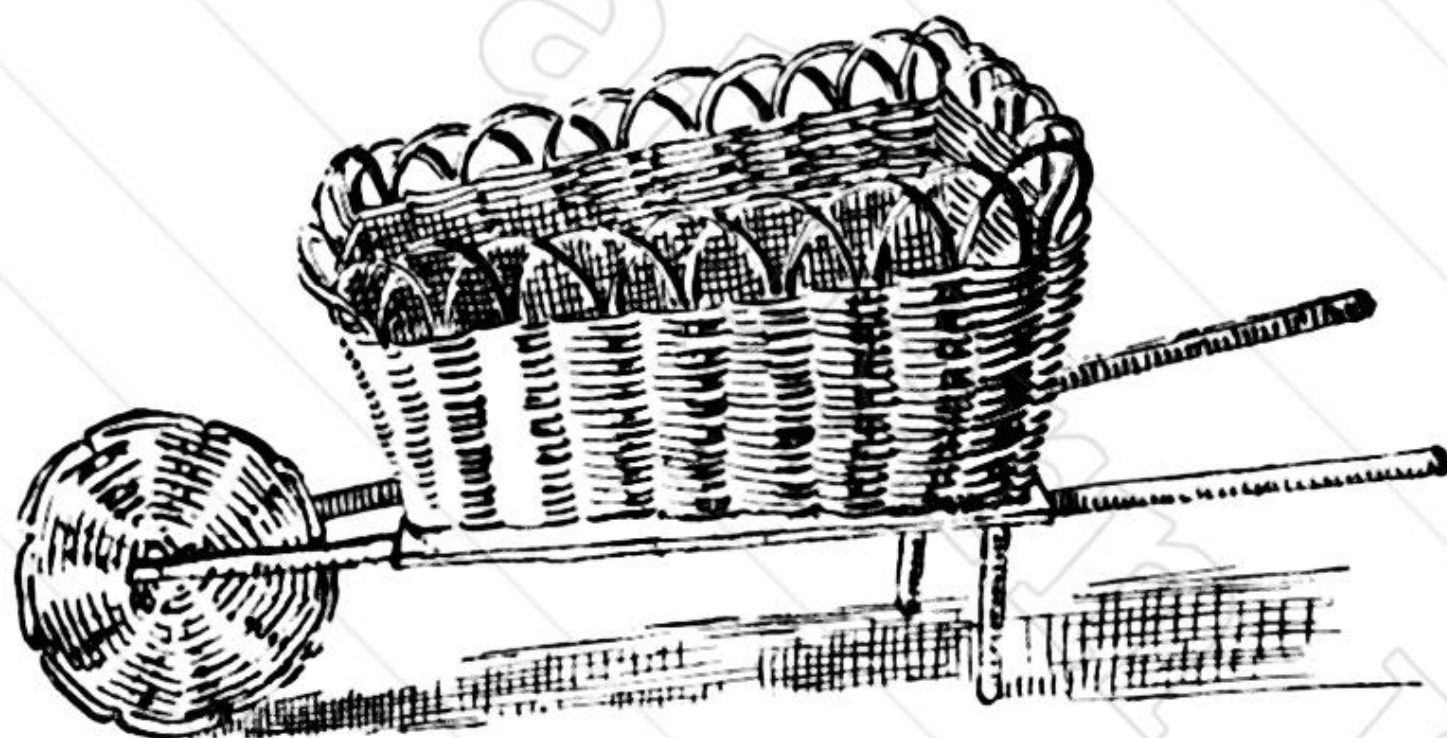

FIG. 165.—Small Wheelbarrow.

holes down the sides, four across the back, and three in the front. The teacher should prepare this diagram accurately and mark places for the holes. The diagram should then be reprinted on cards 5 inches square, and each child be allowed to pierce the holes with a coarse pricker and then cut out the shape.

Cut the cane into lengths of 7 inches, soak it for a short time, and give each child twelve pieces.

Double each length in half and thread the two ends up through two consecutive holes. Weave thirty-four rows until the weaving measures 2 inches in depth. After the first few rows, the rays must be pulled slightly outwards to give a slope to the sides.

Finish off the "rays" according to rule given for No. 3 border (Fig. 151).

The Wheel.—This consists of a small circular mat $2\frac{1}{2}$ inches in diameter. The foundation is most simple, of four strands only, made according to Beginning 1. The "rays" of wheel are woven into the mat according to Border 7 (Fig. 155).

Shafts and Legs.—Cut two lengths of No. 10 cane for the shafts (8 inches long), and two lengths 3 inches long for the legs. These must be pushed up through the corner holes and inserted for strength into the weaving. Kindergarten sticks will answer equally as well as the coarse cane for shafts and legs.

Varnish the cane work and line the bottom of cart with leather paper.

Attach the shafts and wheel together with wire.

Conversation lesson upon wheelbarrow should follow.

THE MAIL CART

This article is a combination of flat and upright circular weaving.

Body of Cart.—Cut an oblong of stout cardboard or very thin wood 8×6 inches. Pierce holes at each corner; these may be done either by a punch or red-hot knitting needle. Next divide the spaces between the corner holes into equal distances of about *one inch*, and pierce holes at each division. On one of the four sides an extra hole must be got in so as to get an *uneven* number of holes for the weaving to alternate properly, therefore choose the front side and divide this into *three-quarter inches*, and so get the extra hole. Weave round about *eight rows* and then insert at each corner hole a stout cane or stick which is needed to keep the

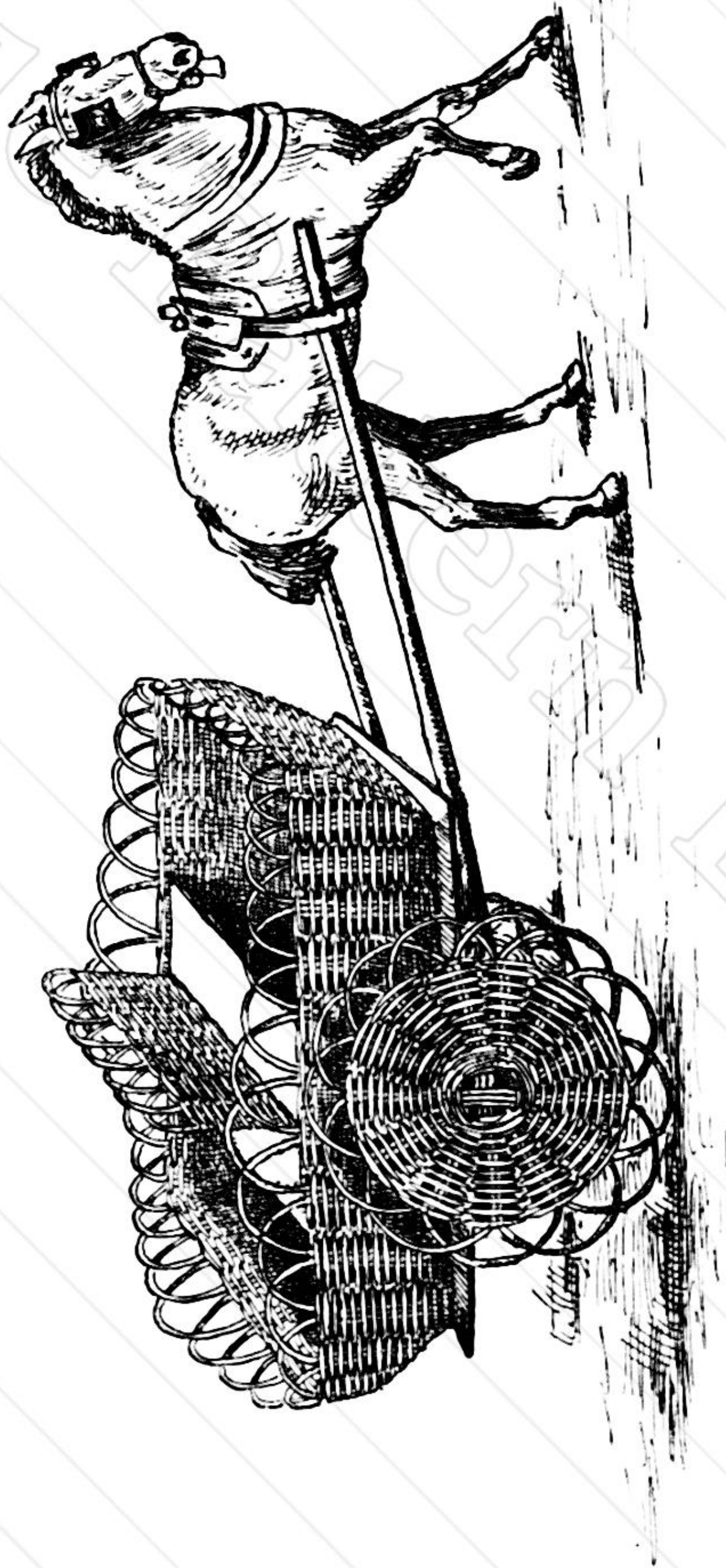

FIG. 166.—Mail Cart.

corners firm and straight. As the weaving proceeds pull it gently outwards to make sloping sides; when the weaving is $3\frac{1}{2}$ inches deep finish off with Border 3, but so vary the height to look high in the centre of each side and graduate towards the corners. The border in front of the cart should be pushed down nearly flat. In punching the holes a space of $1\frac{1}{2}$ inches might be left in front to represent the footboard, and the front row of holes be made $1\frac{1}{2}$ inches from the edge.

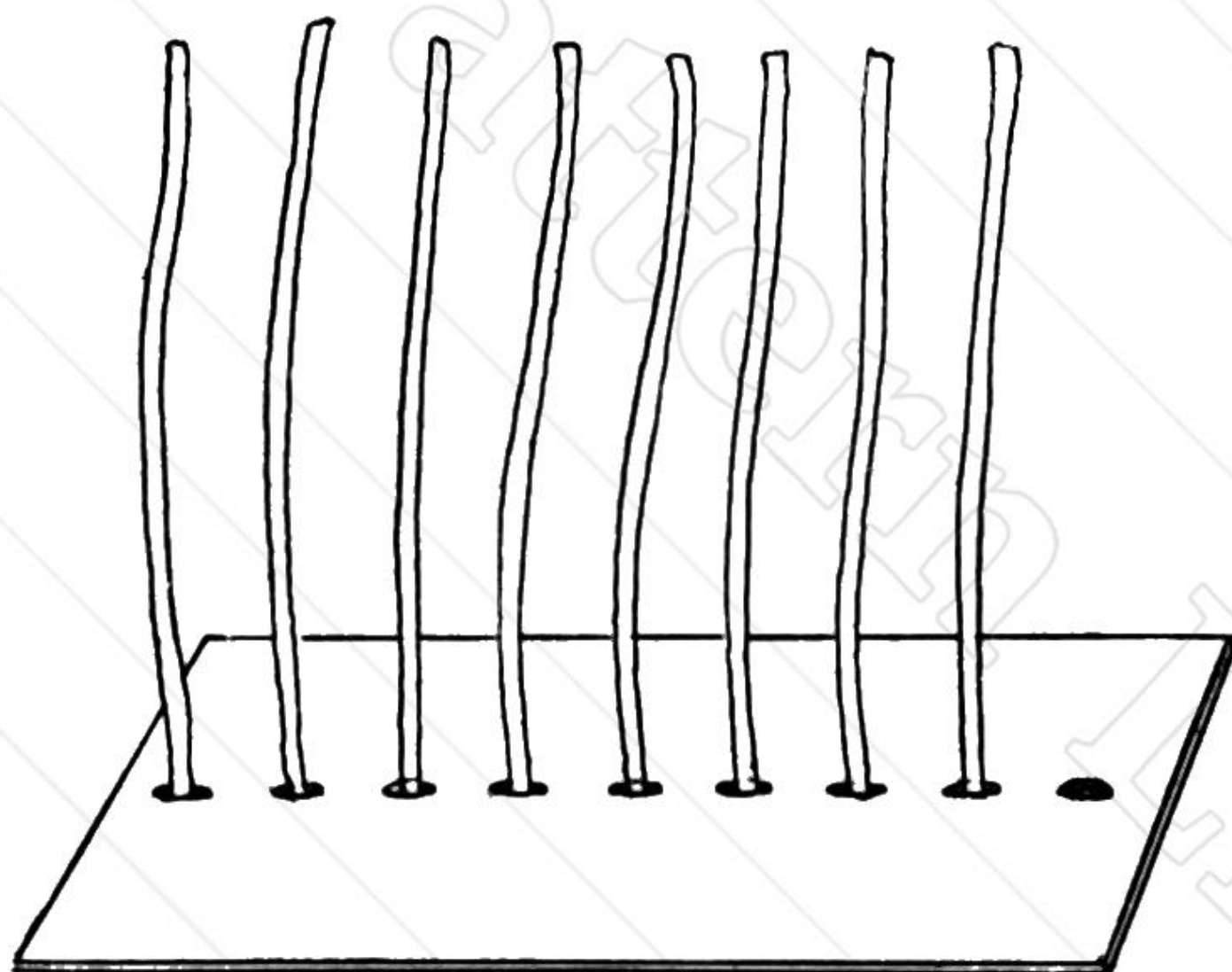

FIG. 167.

The Seat.—Cut a strip of cardboard 3 inches wide and 9 inches long for the seat, pierce holes in the exact centre $\frac{3}{4}$ inch apart, leaving a space each side to form the back and front seat. Cut lengths of cane 7 inches long, double in half, and thread the ends up through two adjoining holes. Weave backwards and forwards for a few rows and then insert a Kindergarten stick at each end to keep the side straight and firm. When about two inches deep finish with Border 3. Paste a strip of velveteen or plush on

each cardboard seat, and secure the sides to the body of cart with a thread of fine cane or wire.

The Wheels.—The wheels consist of two round mats 6 inches in diameter, the foundation for which is of No. 4 cane, and the weaving is done with No. 1. The wheels may be finished off flat, or with a border according to taste.

The Shafts.—Two pieces of wood 12 inches long form the shafts; these are enamelled red and fastened underneath the cart with short French nails and wire.

The Axle.—Another piece of wood 8 inches long and pointed at both ends is fixed across the cart underneath to form the axle. Upon the pointed ends a small narrow reel is threaded, and to this reel the wheels are attached by fine tacks. The reel allows the wheels to revolve upon the pointed ends. A French nail is fixed outside through the point as a linch pin to prevent the wheel from slipping off.

Finishing Off.—The cardboard bottom, axle, and shafts of the cart are all enamelled in post-office red, and the weaving is varnished with clear copal varnish inside and out.

If a sixpenny horse be attached to the cart, it will greatly please the children and form a novel article to show to visitors. Every part can be done by a boy of seven with proper instruction and superintendence. The children delight in making something different to mats and baskets.

The inside is improved by lining with leather paper and adding at front and back two knitted mats of bits of wool or cloth made by the children. Dolls also might be dressed and seated in to make the thing more childlike and realistic.

LADY'S SAILOR-HAT WORK-BASKET

Materials required.—Eight strands of No. 2 cane 20 inches long for the foundation, and No. 1 cane for the weaving.

Method.—The foundation strands are arranged according to No. 3, and a large circular mat, as described on p. 190,

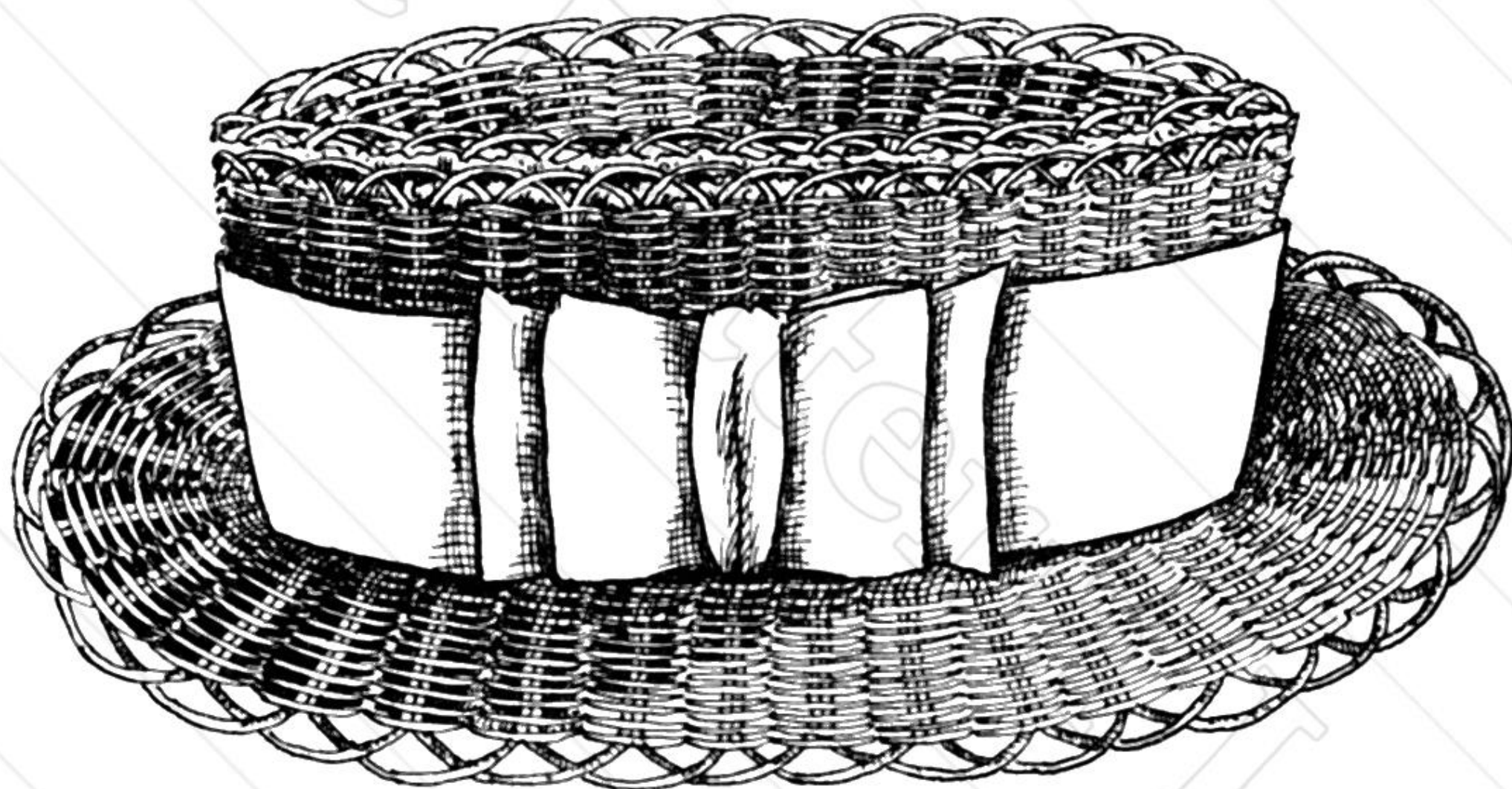

FIG. 168.—Lady's Sailor-hat Work-basket.

is woven for the bottom and rim of the hat. This circular mat must measure 10 inches in diameter without the border, the border may be No. 3.

Upright Weaving.—The principle for upright weaving is applied here. Take ten strands of cane 8 inches long, double in half, and thread up the ends through the mat at equal distances apart, and about twenty rows in from the border. See that the loops underneath are pulled up close and fit into the weaving and are not discernible from it. Start with a weaving thread and push the end up through the weaving, to form the odd strand. Weave round closely to the mat, until the sides are 3 inches deep. Finish off

COMBINED CANE-WEAVING

207

by pushing the spokes close down to the weaving, as described in Border 3.

The crown of hat is made of a circular mat 8 inches diameter, finished off with the same tight border. The crown is attached by a thread of cane to the other portion for about *one inch*, and the remainder opens and shuts as a cover. The inside and cover are nicely lined with a full lining of silk and closed with bow and ends of ribbon. A broad band of satin ribbon finishes the outside to simulate a "lady's sailor hat."

COMBINED CANE-WEAVING

If the children have made flat articles and upright ones with cardboard or wooden bottoms, there will be little difficulty in introducing them to basket-making.

The round shallow basket is the best for beginners to learn upon, because it includes the principal difficulties, and being a small article is easily handled and soon finished.

The difficult parts of basket-weaving are : the beginning and the border. Most of the weaving is plain sailing after the division of the rays is correctly made. Though not really difficult to do when shown, basket-weaving may appear to the uninitiated rather puzzling on paper. The teacher should be provided with a good sharp knife to point and cut the cane, which must be well soaked for an hour before use. For this reason it is not a desirable occupation in cold weather, because of the chapped hands one is liable to get from having them constantly wet.

When making a basket it is often necessary to plunge the whole into water, so as to regulate the shape and keep the cane from getting too dry. The teacher should have at hand a pail of water for this purpose.

There are two ways of weaving, either with *one* or *two* strands of cane at one time. The first is the most simple and is worked "out" and "in," or "above" and "below," until the basket is finished. The other way is to take *two* weaving strands and begin by inserting both in the weaving, and then keep *one outside* and the *other inside* of each foundation ray. Cross the outer length over the inner,

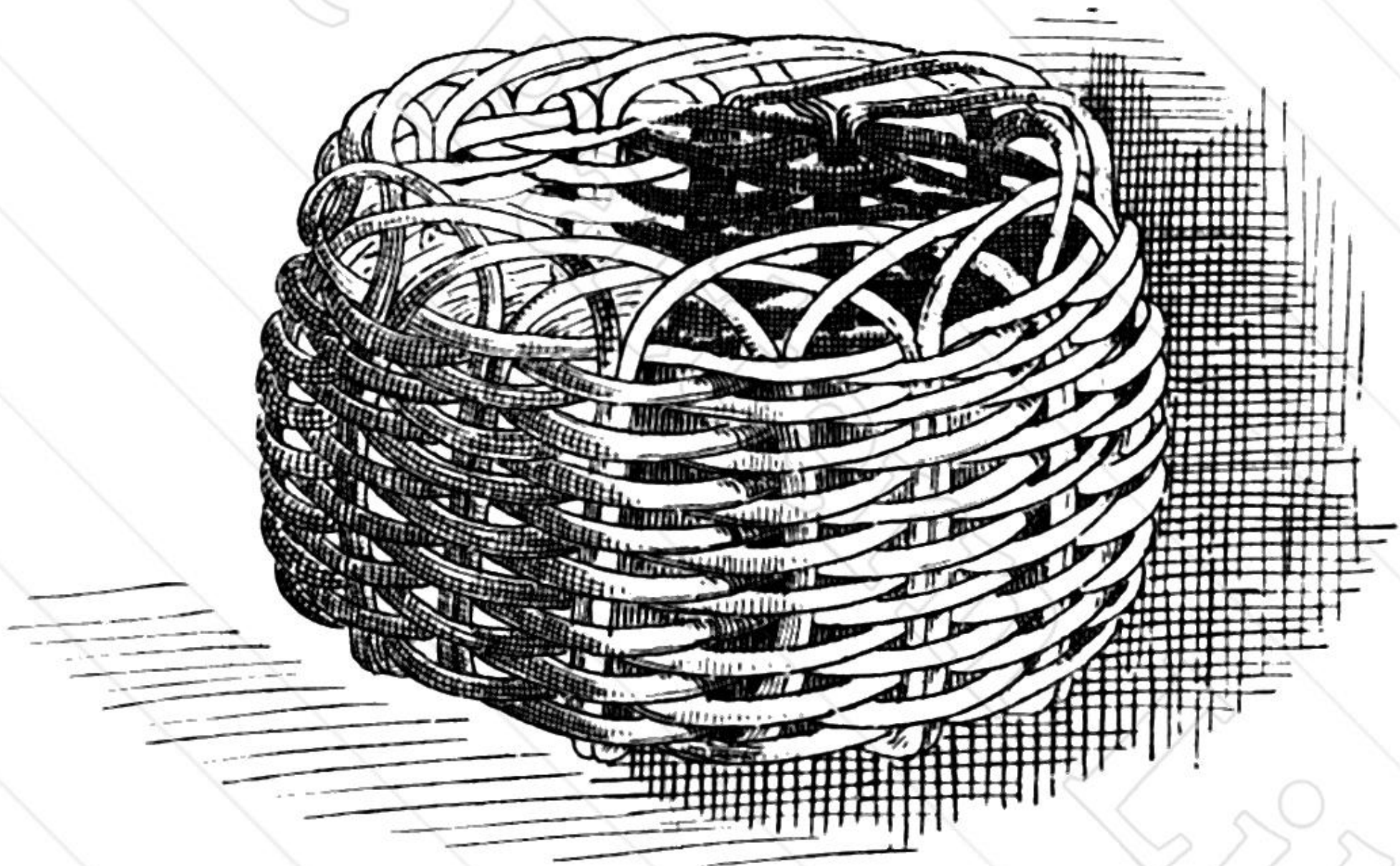

FIG. 169.—Cotton Basket.

between each foundation ray or pair, and continue in this way round and round until the top of the basket is reached. For young children the single weaving is best ; but a row of the double at the bottom of a basket gives additional strength to the sides.

In joining on a new strand it is best to push the end back side by side with the old end. Keep the uprights at *equal* distances from each other and pull them in position as they require it.

A pleasing variety to the work is to let children weave a length of coloured Macramé string *with* the cane. The

COMBINED CANE-WEAVING

209

two must be woven together and the string kept *above* or *below* the cane throughout. Very pretty fancy baskets may be made in this way. A ball of string to use from is necessary, as joins are unsightly.

An *all* string basket is not so good as one of cane and string combined. The cane imparts firmness, whilst the string adds beauty, and therefore the two together look best. There is scarcely any limit to the various shapes which may be made. Some of these require a little thought to be successful, *e.g.* a true horn shape can only be got by introducing from time to time short lengths at the curved portion, because this part needs many more strands to fill it than the upper curve, and if the weaving be done equally the bold horn shape cannot be obtained. A large round mat may be pressed upwards on four sides and tied till dry. It will then do as a flat work-basket, with four corner pockets.

SHALLOW BASKET (THIMBLE)

Material required.—No. 1 cane.

Method.—Cut eight strands of No. 1 cane 12 inches long and begin as described in No. 2. Weave a circle (two over and two under) 3 inches in diameter for the bottom. Turn up the sides and weave to a depth of 2 inches. Finish with Border No. 3, behind one and down side of second. Varnish inside and out. These little baskets are useful for school use to hold the thimbles used in class.

COTTON BASKET

Material required.—No. 1 cane.

Method.—Cut eight strands of cane 20 inches long and begin according to No. 3. Weave a circle for twenty rounds,

P

two over and two under, then subdivide into "ones," and continue the circle until it measures 5 inches in diameter.

Sides.—Turn up the rays and weave the sides to the depth of 3 inches, exclusive of the border. The upper rounds may be gradually tightened to give a more artistic shape, or spread out flower-pot shape.

Border No. 3.—Over the first, under the second, down by the side of the third. Useful for cotton or thimbles.

DOLL'S FISH-BASKET

Materials required.—1. Cane No. 0 for weaving.

2. Cane No. 00 for foundation.

Method.—Take eight strands of cane 10 inches long and begin as in No. 2. Weave a small circle of $1\frac{1}{2}$ inches for the bottom, keeping the rays in pairs throughout. Turn up for the sides and weave to a depth of 2 inches, gradually widening the distance between the rays until the basket measures 3 inches across the top.

Border.—Take each pair of rays and push close down by the side of the next pair, as in Border 2. Leave one pair raised $1\frac{1}{2}$ inches to form a loop, and twist this pair before pushing the ends into the weaving. This loop represents the handle. A French fish-wife might be dressed in class and one of these baskets attached to her back, to give children an idea of its use. Little baskets with two handles might be made in a similar way, and filled as hampers of sweets, etc.

SMALL CARD-BASKET

Materials required.—1. No. 4 cane for foundations.

2. No. 1 cane for weaving.

Method of Lesson.—Cut eight lengths of No. 4 cane 26 inches long and cross them and begin as in Fig. 140. Weave for the bottom a small round mat 4 inches in diameter. Slightly cut the foundation rays and turn up for the sides. Continue weaving one over, one under, for a depth of 2 inches, keeping the weaving nearly upright. Push the end into the weaving to finish.

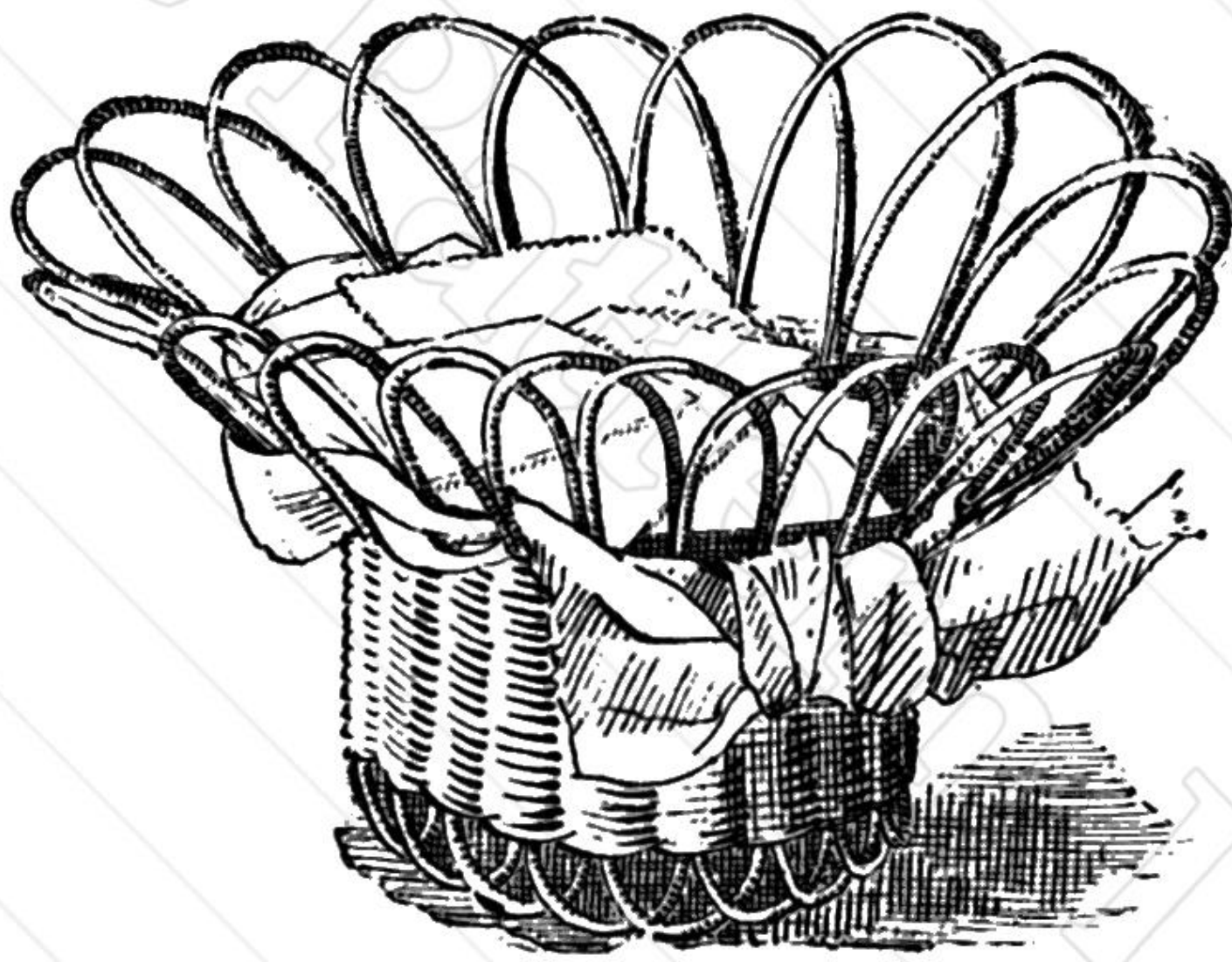

FIG. 170.—Small Card-basket.

Border.—Most of this basket consists of the border which is woven both top and bottom.

Top Border.—Take a ray which measures about ten inches and pass it behind the next ray and over the second and down by the side of the third. Take the ray next to it and do the same, that is:—Pass behind, out and over, in and down by the side. Each ray is pushed down through the whole of the side weaving, until it protrudes $1\frac{1}{2}$ inches at the bottom.

Lower Border.—Turn the basket upside down and curve each end into a semicircle. Take one end, pass it to the left, behind the next, and down by the side of the second

from it. Continue the same method with each one, and the result will be an open foot-stand for the basket to rest upon. The upper border is interlaced with a piece of wide satin ribbon tied in a bow, and the well of basket is lined with gathered silk of the same shade. This little article is useful for table use either for cards or cottons.

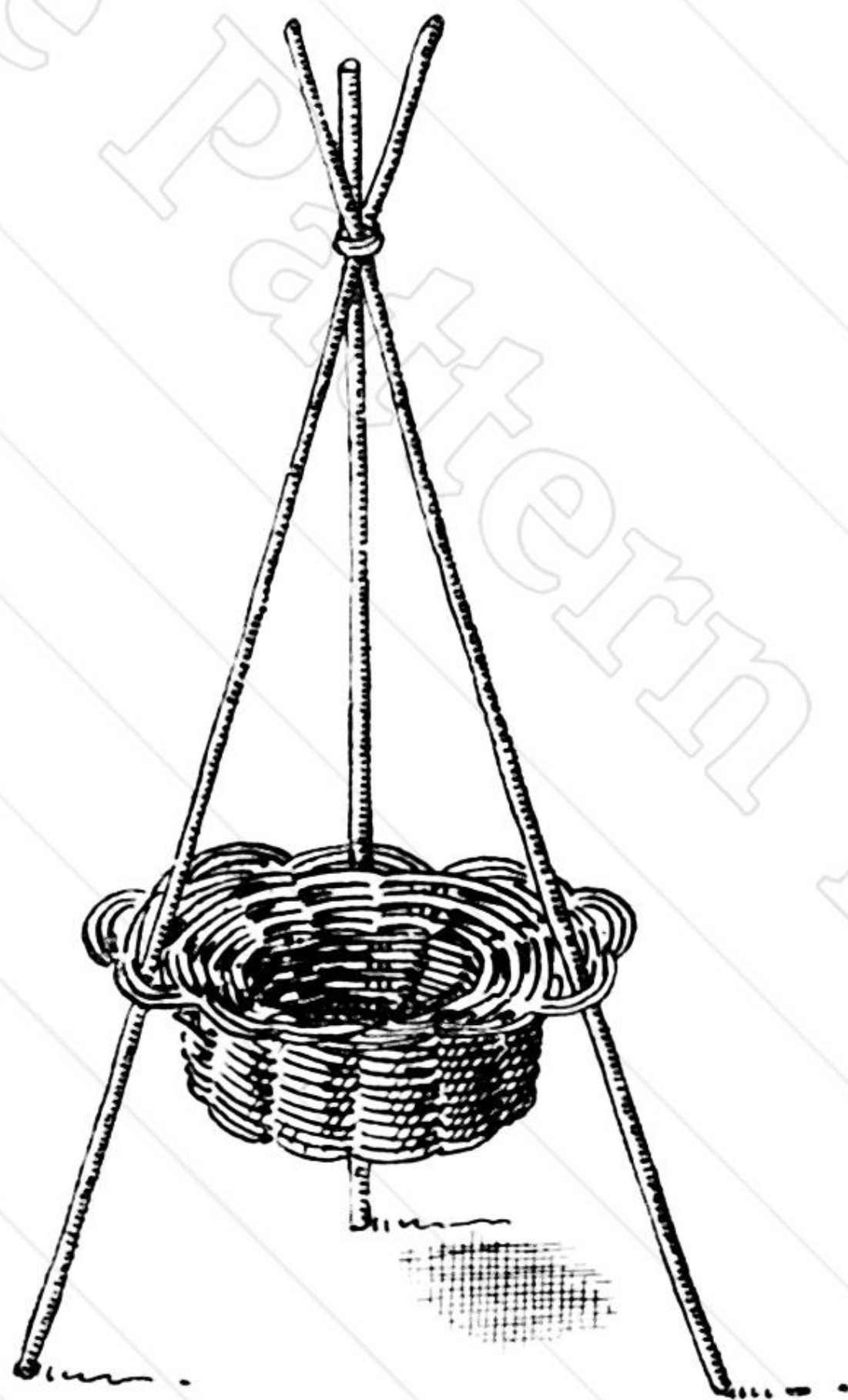

FIG. 171.—Doll's Sailor Hat Fern-stand.

DOLL'S SAILOR HAT

- Materials required.**—1. Cane No. 1 for foundation.
2. Cane No. 00 for weaving.
3. Three Kindergarten sticks.

Method of Lesson.—Take four lengths of cane 6 inches long and begin as in No. 1. Weave two over and two under until the crown is $1\frac{1}{2}$ inches in diameter. Turn up the rays, keeping them perfectly straight up and in pairs until the sides are done. Weave to a depth of 1 inch for the sides and then turn out the rays for the brim. This part may be done flat on the desk and treated in the same way as a circular mat. Let the rim measure about one inch in width, and then finish off with a close border, as described in Border 7. Varnish the hat inside

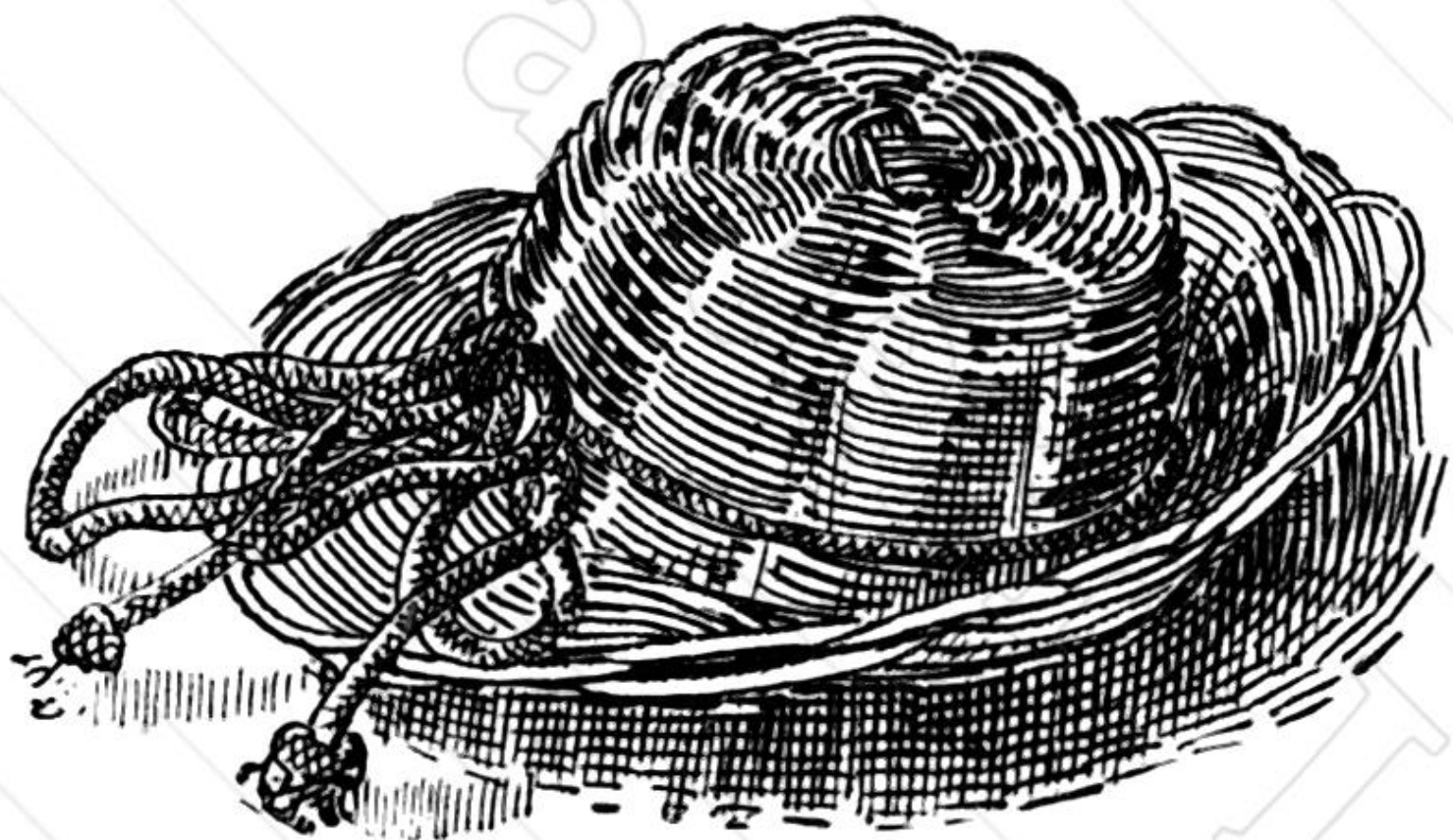

FIG. 172.—Turned-up Doll's Hat.

and out, and be careful to notice when turning up the rays for the sides that the neatest side of the beginning goes outside for the top of the crown. These little hats may be made sufficiently large to hold a small fern-pot similar in design to the miniature fern-stand in Fig. 171. Three Kindergarten sticks are used in this case for the tripod, but small canes could be substituted for one of larger size.

TURNUED-UP DOLL'S HAT

Material required.—No. 00 cane.

Method.—Cut eight lengths 8 inches long and inter-
ace two pairs into two pairs, as shown in No. 5. Leave

an odd strand and weave a small circle of $1\frac{1}{2}$ inches diameter for the crown. Separate the pairs of rays into "ones," and continue till the crown is $2\frac{1}{4}$ inches in diameter. Turn up the rays for side and keep these gradually sloping outwards. Let the sides measure about $1\frac{1}{2}$ inches deep before making the brim.

Brim.—For the brim place hat on desk with crown uppermost and bend out the rays for brim. If both sides of hat are to be turned up, gently bend the rays on each side back towards the crown, but do it on one side only for the hat in Fig. 172. Weave on round the brim like a flat mat either on the desk or in the hand, whichever is easier, and make a good brim of 2 inches wide.

Border.—The border may be open or close as desired. Soak the hat in warm water and press into a good shape and leave to dry. Varnish or enamel when dry and trim with ribbons or cord and tassels.

HAMPER OR TUMBLER CASE

This is a very simple and useful little article. Only four strands are required for the foundation, and these must be *12 inches* long. Cross two over two and begin as in Beginning 1. Weave eight rows, two over and two under, and then divide into ones; weave a circle of 2 inches diameter for the bottom, then turn up and weave the sides 3 inches deep, gradually widening till the top circle measures 3 inches. Finish by pushing the spokes close down to the bottom of the sides, thus forming a foundation of double strands. There is no border, but each spoke is pushed down close by the side of the next.

The Cover.—For the cover begin as before with four foundation strands and weave exactly another circle like the bottom of the basket, only of 3 inches diameter.

COMBINED CANE-WEAVING

instead of two. The border of the cover is finished in the same way as the case.

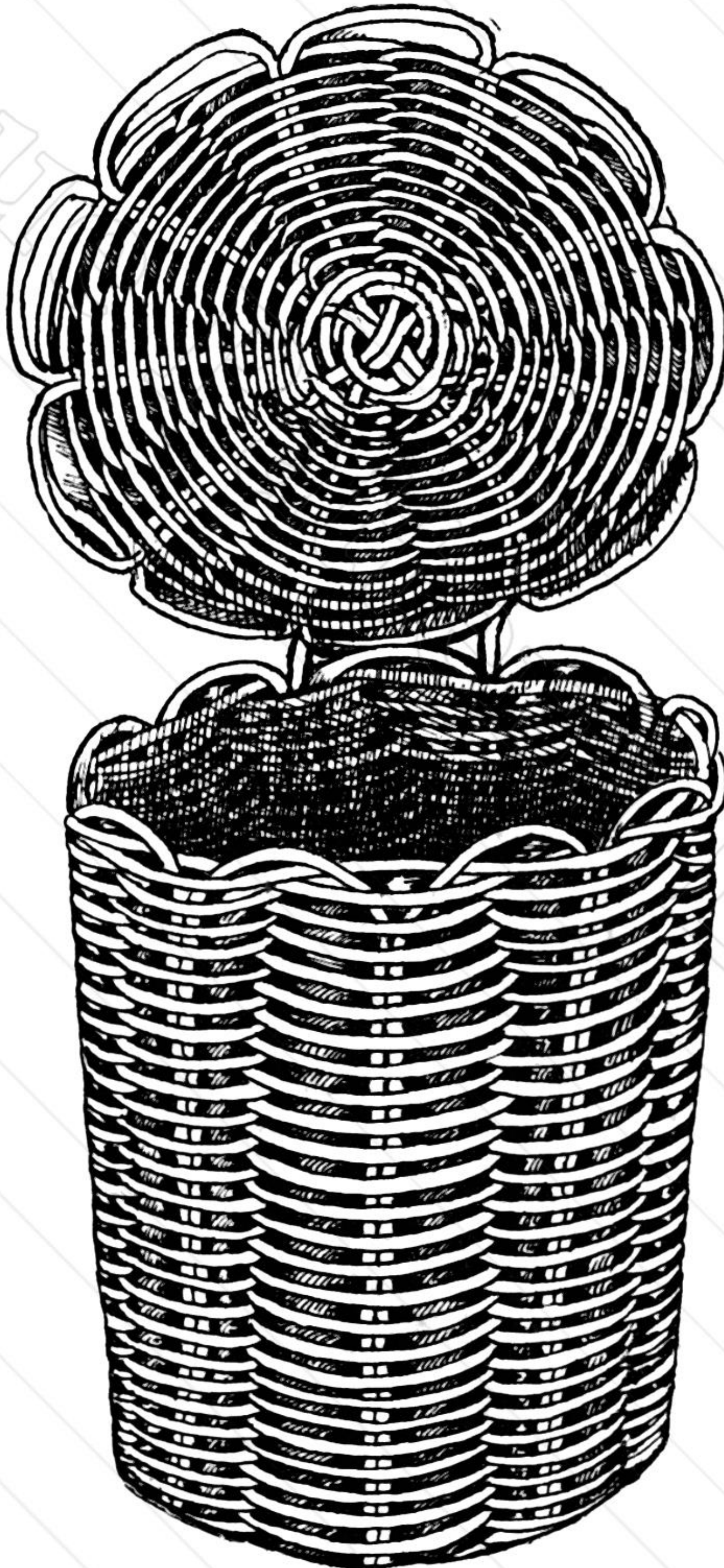

FIG. 173.—Hamper or Tumbler Case.

Use.—Place a small claret tumbler inside, and this little article will then be useful for travelling purposes, or fill the case with fancy sweets or chocolate and tie the outside with cross ribbons and bows, and it then becomes a pretty present for a child or article for a bazaar.

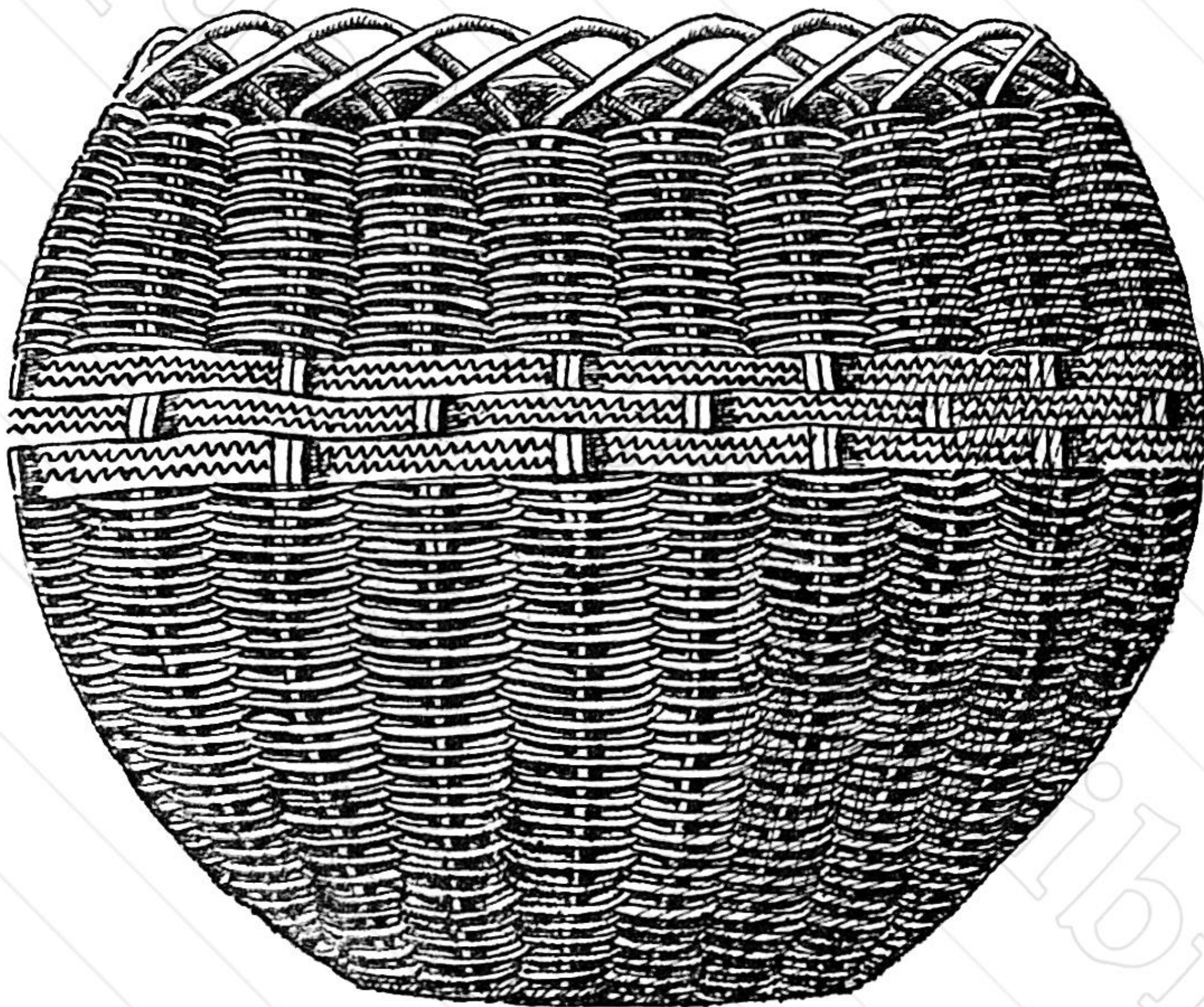

FIG. 174.—Art Pot.

ART POT

The art pot is 8 inches high from the base to the border, and 23 inches round at its widest part, narrowing to 20 inches at the top.

The foundation consists of 8 strands of No. 4 cane 24 inches long. The beginning is made according to "No. 2"; about ten rows are woven, two over and two under, and then sub-

COMBINED CANE-WEAVING

217

divided into "ones"; the bottom measures $3\frac{1}{2}$ inches in diameter, after which the strands slope gently outwards till the sides are $\frac{1}{4}$ inches deep and 23 inches in circumference. At this point three lengths of narrow straw plait, crimson and cream, are interwoven, and very much improve the appearance of the pot. The cane-weaving is continued for nearly two inches, and the foundation spokes are drawn gradually closer until the circumference measures 20 inches. The border is finished off according to "Border 4," over three and down by the side of the fourth.

The small art pots or an ordinary flower-pot will fit inside and the article is useful for indoor plants.

OVAL HAND-BASKET

Materials required.—1. No. 3 cane for foundation strands.

2. No. 1 cane for weaving.

Method of Lesson.—Make an oval 9 inches long and $4\frac{1}{2}$ inches wide according to directions given for oval dinner-mat. Wind in this case eight times round a piece of wood 16 inches long, and interlace six strands about three-quarters of an inch apart. The strands must measure when cut 32 inches, as they form the foundation strands of the long way of the basket. The cross strands must measure 30 inches in length, and these form the foundation rays of the sides of the basket. When the oval for bottom is of the required size, slightly cut with penknife all the foundation rays so that they turn up easily. Now take *two* weaving strands, push the ends into the wicker and begin to weave with both, one to go inside and the other outside of each ray, cross them each time and repeat all round until both threads are used up. This mode of weav-

ing is the one generally used by basket-makers. In this instance it is introduced to give a firmness and uprightness to the side strands of basket. The sides of the basket are woven two rows alike and then alternated. Weave in this manner until the basket is 5 inches deep, then finish the



FIG. 175.—Oval Hand-basket.

top rows in the same way as the lower ones—that is, with two weaving threads, one outside and inside, cross and repeat. To give additional strength to the sides an extra spoke is added to the side of each foundation ray, so that all the rays are doubled.

Border.—Take a pair of rays, pass them to the left behind

COMBINED CANE-WEAVING

219

the next two pairs and down by the side of the third. Take next pair and proceed in the same way and continue till the whole border is finished (see No. 5).

Handle.—Nine lengths of No. 4 cane 27 inches long are required for the handle. Take three at a time and push down into the weaving by the side of three adjoining pairs of rays. They should reach well to the bottom of basket. Take each set of three rays and plait the nine in the ordinary plait of three. Leave 4 inches unplaited and insert these ends into the opposite side to correspond with the other. The handle may be secured still further with wire, but if used for light articles there will be no need of this, as the varnish acts like glue and makes the whole firm and strong. Varnish thoroughly inside and out.

FERN-STAND FOR TABLE

- Materials required.**—1. Two bamboo canes $\frac{1}{2}$ d. each.
2. Fine cane *No. 1* for weaving.
3. Medium cane *No. 4* for foundation.

Plan of Teaching.—The three flower-pots at the base of the stand are of the same size, as also are the three fern vases at the top.

1. FERN VASES

Take eight strands of fine cane about *twenty-four inches* long. Lay them in position four across four and make a beginning according to Rule 2. When four rows have been woven and the centre tightly secured, turn up the spokes at once and weave over two and under two for sixty rounds or to a depth of $\frac{1}{4}$ inches, gradually widening the foundation strands as the weaving proceeds. This widening comes naturally, and it is one of the difficulties to be overcome, if the article requires perfectly straight sides. The

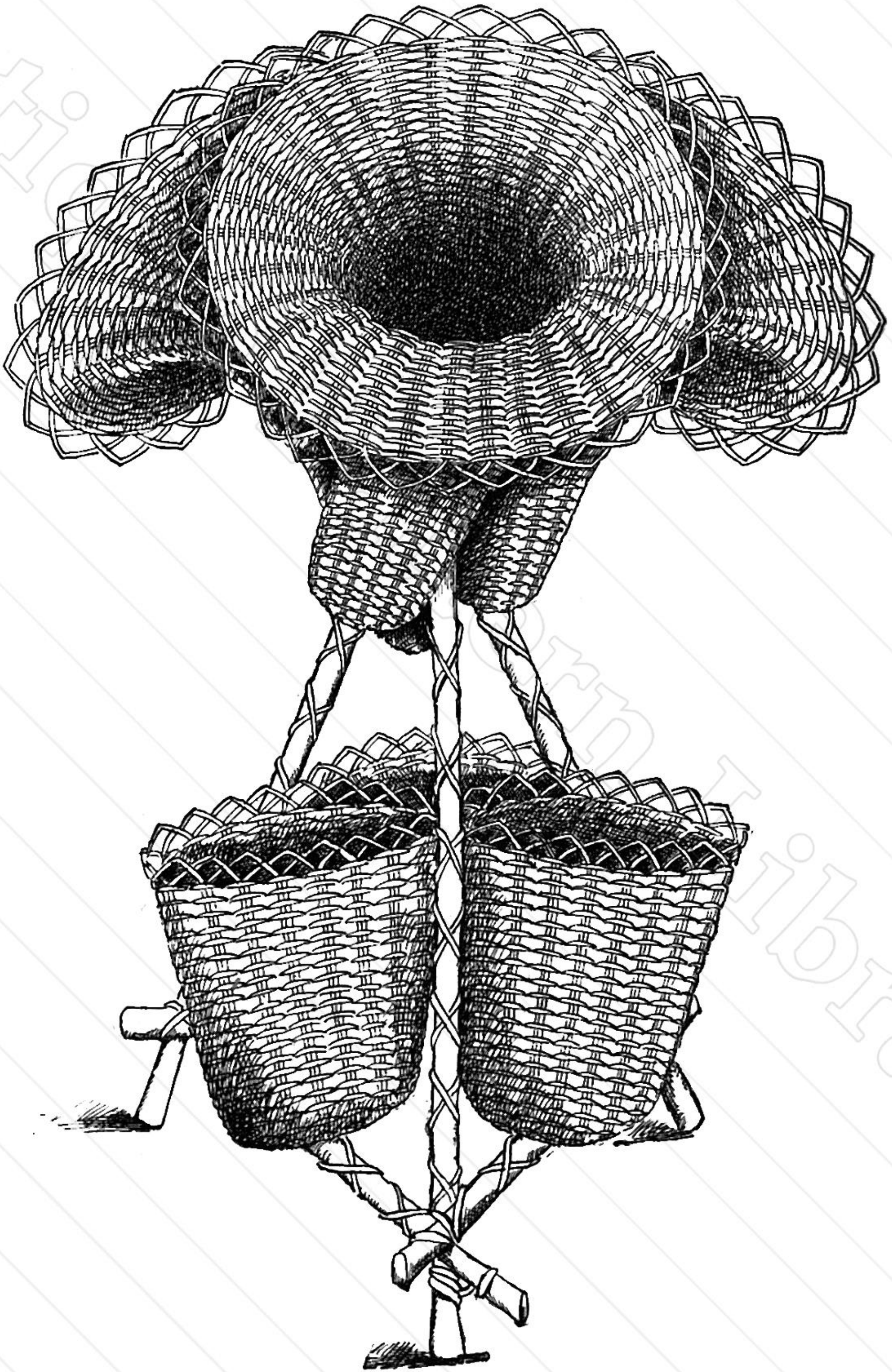

FIG. 176.—Fern-stand for Table.

COMBINED CANE-WEAVING

221

spokes are now subdivided into "ones" and the weaving continued for another *4 inches*, still increasing the width until the circumference measures about *twenty-six inches*. Cut the spokes of equal length and finish with Border No. 3.

2. FLOWER-POT

The foundations of the pots are made of No. 4 cane, because the upright sides need a firm support to keep them straight. For the foundation take *eight strands 18 inches* long and make beginning according to No. 2. Weave a circle, two over and two under, of 3 inches diameter for the bottom, turn up the spokes, weave *eight rows* and then divide into "ones," continue weaving till the sides measure *5 inches* deep, and then finish the rays with Border No. 3.

3. THE TRIPOD STAND

Take two bamboo canes and cut three lengths of *20 inches* and three more lengths of *11 inches*. Fasten the long lengths together about *five inches* from the end and wind round and round with fine cane. Tie the three shorter lengths into a triangular shape and fasten the ends of the long pieces into the outer angles, wind round with cane, and finish off by crossing all the tripod with twists of fine cane. Tie the three vases together and fasten to the tripod with a thread of fine cane, as shown in Fig. 176.

The stand is suitable for the centre of a table—the lower part might be filled with ferns in pots, and the upper portion with tins of cut flowers or grasses. Varnish the whole inside and out.

FERN VASE WITH STAND

This vase is made similar to the others. It is a little larger, with deeper well, and in addition has a foot-stand

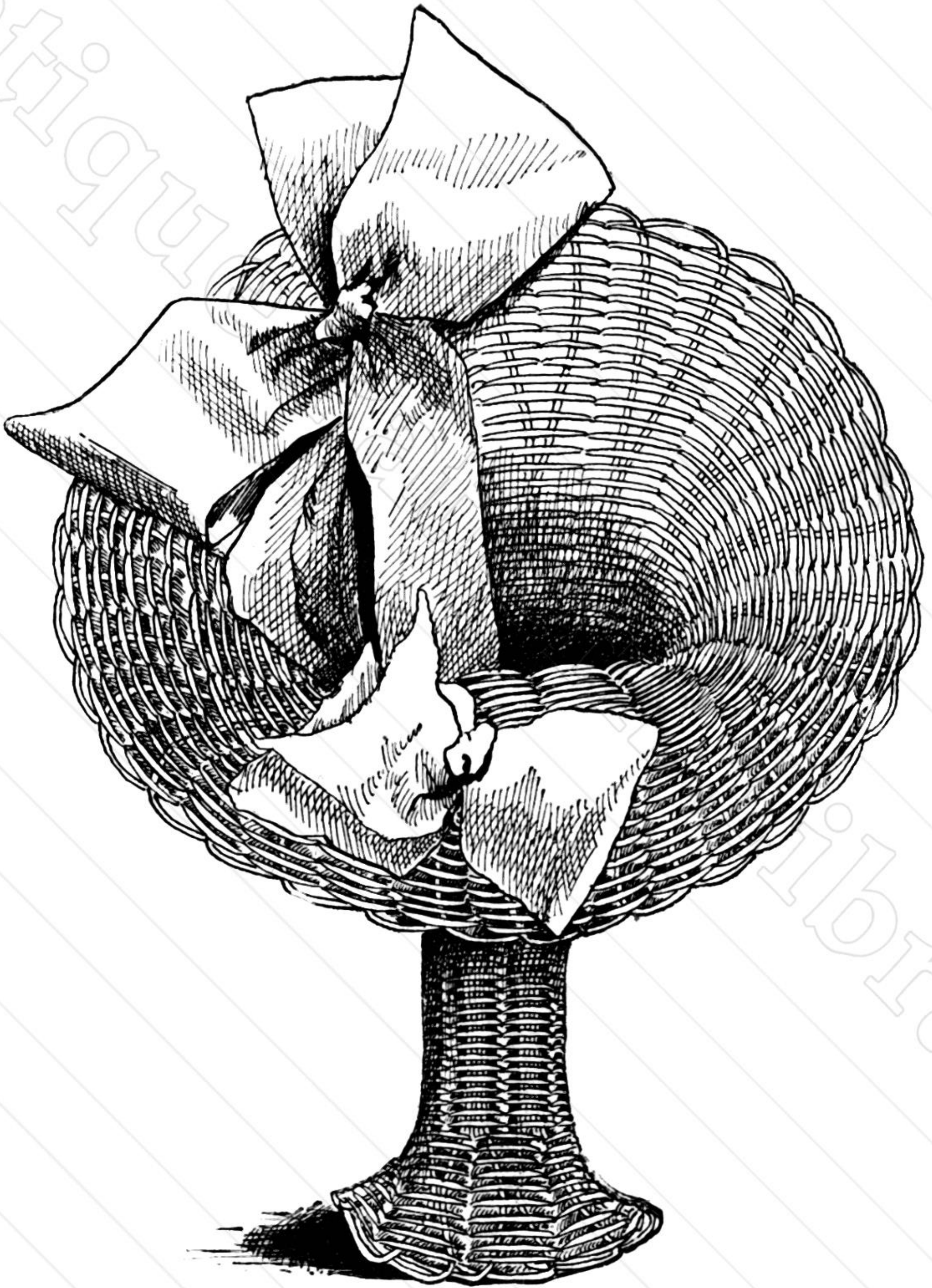

FIG. 177.—Fern Vase with Stand.

COMBINED CANE-WEAVING

223

added, so that it could be adapted for hanging or standing purposes.

Make the vase exactly as before described, with longer foundation strands, and plunge it occasionally into water to regulate the shape. When finished tie the circular top in position and leave in water till thoroughly wet, and allow



FIG. 178.—Vase for Flowers.

string to remain until the cane work has dried, when the shape will remain unaltered.

The Foot.—Cut lengths of cane of 6 inches and insert one at each ray of the apex, to run by the side of the foundation strands. First insert a knitting needle and push the short lengths in its place. Spread out these strands nearly flat on a table or desk and begin to weave round them just in

the same way as a small mat. Turn the vase upside down to finish, and widen the spokes as the weaving proceeds. Weave about two inches, and finish off with a fancy or plain border, whichever is desired.

VASE FOR FLOWERS

These fern vases are easily made by the children, and there are many ways of using them; some may be used singly as a receptacle for flowers or grasses. First procure a small tin spice canister, enamel it inside and out to keep it from rust, and then place it in the well part of the fern vase and fill with flowers, as in Fig. 178. Others look well mounted. Cut very stout cardboard or thin wood into an artistic shape, such as a diamond, heart, or shield shape, then fix in position two or more fern vases, ornament with bows of ribbon, fill with coloured artificial grasses, and the result will be a very pleasing and useful article for wall decoration.

THE END

Printed by R. & R. CLARK, Edinburgh.



**STRUTTS'
SCHOOL
REQUISITES.**

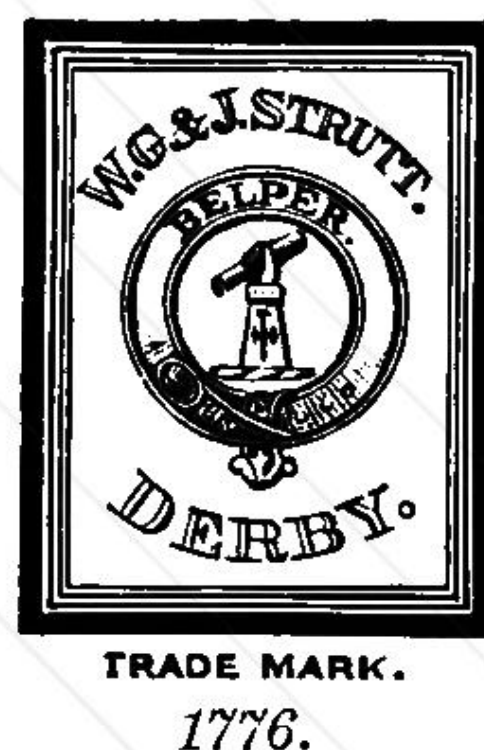

W. G. & J. STRUTT

MAKERS of KNITTING COTTON, in colours, white, and unbleached; suitable for use in Schools.

Contractors to the London School Board.

STRUTTS' MACRAMÉ TWINES, in 42 shades.

Size No. 10, expressly made for winding on cardboard picture and photo frames.

Size No. 5, suitable for making mantel borders, table fringes, and handbags.

Ask for STRUTTS' MACRAMÉ BOARDS, the most extensive variety, and the best make in the market.

STRUTTS' COLOURED CROCHET COTTON, in 40 shades, is unexcelled.

WHOLESALE ONLY:

BELPER,

AND AT

15 MANCHESTER AVENUE, LONDON, E.C.,

RETAIL AT ALL SCHOOL STATIONERS, DRAPERS, AND
FANCY REPOSITORIES.

KINDERGARTEN

Materials kept in Stock for
**CARDBOARD MODELLING, PAPER DESIGNING,
PAPER FOLDING, PAPER PLAINTING,
CANE WEAVING, ETC. ETC.**

A NEW AND COMPREHENSIVE WORK ON PAPER PLAINTING, containing Introduction, Rules, etc., together with about Twenty-eight Plates of Illustrated Designs. By ELEONORE HEERWART. Price 2s. net.

TWELVE KINDERGARTEN ACTION SONGS.

Containing a New May Pole Dance, and Skipping Song, with full directions. Words by ALICE M. PUGH, Music by ERNEST A. DICKS, F.R.C.O. Price 1s. net.

A complete Catalogue of Kindergarten Materials sent post free upon application to

CHARLES & DIBLE,
THE CITY KINDERGARTEN WAREHOUSE,
25 PATERNOSTER SQUARE, LONDON, E.C.

KINDERGARTEN FOR SCHOOL AND HOME.

The Standard Publications and Materials, arranged according to the best Authorities in the most accurate and systematic style, are issued by

A. N. MYERS & CO.,
15 BERNERS STREET, LONDON, W.

CATALOGUES ON APPLICATION, INCLUDING—

MATERIALS for Paper Folding, Paper Cutting, Paper Weaving, Straw Plaiting, Cane Weaving, Bead Work, Basket Work, Flower Work, Clay Modelling, Card Modelling, Word Building; Easy Course of Drawing, by E. HEERWART; Painting for Children, by E. HEERWART and H. RIDLEY.

Model Clock Face, 2s.	First Sewing Lessons, 3d.
Lightning Clock Dial, 1s.	Stepping Stones to Embroidery, 4d. and 8d.
Standard Bead Calculator, 2s. per dozen.	Date Rack for Little Fingers to Work, 1s.
Butters's Tangible Arithmetic, 4s. 6d.	
Gymnastics Without Apparatus, on ROTH, 1s.	Ling's Swedish System, by Dr. M. Etc. etc.

KINDERGARTEN CLASSES

CONDUCTED BY

Miss CAROLINE PATTISON, A.F.S.

Only Silver Medallist, Health Exhibition, for Practical
Kindergarten Teaching,

Are held on Saturday Mornings and on Wednesday Evenings,

AT THE

DAY TRAINING COLLEGE,

WHITE STREET, FINSBURY STREET, AND ROPEMAKER STREET,
MOORFIELDS, LONDON, E.C.

The Students in these Classes are examined annually by

FRÄULEIN HEERWART,

President of the International Kindergarten Association.

And Certificates are awarded to the competent. These Certificates are recognised by the School Board for London, and by the Managers of Board and Voluntary Schools all over the Kingdom.

The instruction in Class includes most of the VARIED OCCUPATIONS which can be taken up in School.

Special Classes for certain Occupations are held on Monday and Thursday evenings.

Please write for Prospectus and full Particulars. All applications to be addressed to PROFESSOR CUSACK.

WORKS BY

ELIZABETH ROSEVEAR,

Senior Teacher and Lecturer on Needlework at the Training College,
Stockwell, London.

A TEXT-BOOK OF NEEDLEWORK, KNITTING, AND CUTTING-OUT, with Methods of Teaching. By ELIZABETH ROSEVEAR. With Original Illustrations and Sectional Diagrams. Second Edition. Revised and Enlarged. Crown 8vo. 6s.

NEEDLEWORK, KNITTING, AND CUTTING-OUT, for Older Girls. By ELIZABETH ROSEVEAR. With Original Illustrations and Sectional Diagrams. Globe 8vo.

STANDARD IV., 6d.

STANDARD V., 8d.

STANDARDS VI., VII., and Ex-VII., 1s.

NEEDLEWORK: A Manual of Needlework, Knitting, and Cutting-Out, for Evening Continuation Schools. By ELIZABETH ROSEVEAR. With Original Illustrations and Sectional Diagrams. Globe 8vo. 2s.

MACMILLAN AND CO., LONDON.

DOMESTIC ECONOMY.

A PRIMER OF DOMESTIC ECONOMY. By E. A. BARNETT and H. C. O'NEILL. Pot 8vo. 1s.

SATURDAY REVIEW—"A capital little book for the young householder. . . . It is the excellent merit of this handbook that its teaching takes a most practical form, and is strictly elementary. It lays down a sure foundation of first principles for the use of the beginner, and altogether we do not know a better little book on a great subject than this."

GLASGOW HERALD—"It is exceptionally well planned, and the information about house-building, drainage, food and clothing, cooking, heating, nursing, and the common economies of daily life is both valuable and well arranged."

HOUSEHOLD MANAGEMENT AND COOKERY. By W. B. TEGETMEIER. Pot 8vo. 1s.

PALL MALL GAZETTE—"A sensible and thoroughly practical manual. . . . It can be consulted readily, and the information it contains is given in the simplest language."

EDUCATIONAL TIMES—"This sort of book, which has long been wanted, ought not to be confined to Board Schools. . . . By its careful study a girl can be educated, not only to become a valuable servant, but also a good and sensible housekeeper."

MIDDLE-CLASS COOKERY BOOK. Compiled and Edited for the Manchester School of Domestic Economy and Cookery. Pot 8vo. 1s. 6d.

EDUCATIONAL NEWS—"A little book capable of imparting a great amount of instruction in regard to the practical art of cookery. Its directions are clear and precise; and it aims at no dishes but such as may be prepared from the ordinary materials employed in the kitchens of middle-class people."

MANCHESTER GUARDIAN—"This is a very excellent little book of its kind, and it is only a pity that it is anonymous."

SCHOOL GUARDIAN—"We can heartily commend the *Middle-Class Cookery Book* as an admirable little volume upon a subject of general interest."

SCHOOLMASTER—"It is a laudable object to enable girls who are learning to cook to prepare a few inexpensive delicacies as well as cheap dishes."

THE SCHOOL COOKERY BOOK. By Miss GUTHRIE WRIGHT. Pot 8vo. 1s.

DRESSMAKING. A Technical Manual for Teachers. By Mrs. HENRY GRENFELL. Pot 8vo. 1s.

PRINCESS—"It is a thoroughly practical little work, and contains information on all points relating to dressmaking. It is also embellished with numerous diagrams, which considerably enhance its value as a technical manual."

CUTTING-OUT AND DRESSMAKING. From the French of Mdle. E. GRAND'HOMME. With numerous diagrams. Pot 8vo. 1s.

MACMILLAN AND CO., LONDON.

Antique Pattern Library

